

Ditch Witch[®]

JT3020 Mach 1 All Terrain Tier 3

ISSUE NO. 10PL-06/11

For Replacement Copy Order **P/N 053-1149**

This product is covered by one or more of the following patents:

US 4,953,638; 5,148,880; 5,242,026; 5,341,887; 5,490,569; 5,684,466; 5,713,423, 5,740,703; 5,758,553; 5,794,719; 5,880,680; 5,941,322; 6,085,852C1; 6,109,371; 6,179,065; 6,216,803; 6,250,403; 6,250,404; 6,290,606; 6,311,790; 6,411,094; 6,543,551; 6,550,547; 6,672,409; 6,739,413; 6,761,231; 6,776,246; 6,808,210; 6,827,158; 6,848,506; 6,871,712; 6,896,077; 7,000,710; 7,011,166; 7,013,990; 7,018,164; 7,025,152; 7,038,454; 7,111,693; 7,150,331; RE37,450; RE37,923; RE37,975; RE38,418

AU 689,533; 706,544; 718,034, 755,862

CA 2,156,398; 2,217,899

FR 674,093

DE 694 17 019; 695 29 634; 697 28 716;

EP 0927892; 1466068

GB 2,312,006; 2,418,553; EP674,093; EP817,901; EP846,841; EP927,892

JP 3,458,247

Other U.S. and foreign patents pending

This manual contains information concerning the following models:
JT3020 Mach 1 All Terrain Tier 3 Directional Drilling System

Copyright 2007, 2008, 2009, 2011 by The Charles Machine Works, Inc.



Ditch Witch, Ditch Witch, CMW, AutoCrowd, Jet Trac, Roto Witch, Subsite, Fluid Miser, Power Pipe, Super Witch, Pierce Arrow, Zahn, The Underground, and The Underground Authority Worldwide are registered trademarks of The Charles Machine Works, Inc.

ID0184852

FOREWORD

This manual contains illustrated parts lists to help you select quality ProTech[®] Replacement parts for your Ditch Witch[®] equipment. Using other replacement parts will lessen the productivity of your equipment.

- ◆ Part numbers enclosed in a box are no longer available from The Charles Machine Works, Inc. Your local Ditch Witch dealer may be able to locate the part for you.
- ◆ Footnotes provide more information to help you identify parts shown in the manual.
- ◆ Assembly instructions and Tech Bits articles referenced in footnotes are available through your local Ditch Witch dealer.
- ◆ Description and specifications in this book were current at publication. However, The Charles Machine Works, Inc. reserves the right to improve equipment, so this manual might not reflect the most current improvements.
- ◆ Instructions on recommended equipment use and maintenance are in the Operator's Manual that was shipped with your equipment.

Keep the following in mind when ordering ProTech replacement parts:

- ◆ Specify parts you need by part number and description, not by illustration reference numbers.
- ◆ Have equipment model and serial number on hand to help ensure you get the right parts for your machine whether it's old or new.

Thank you for buying and using Ditch Witch equipment and ProTech replacement parts.

WARRANTY

DW WARRANTY Policy
July, 2005

POLICY 1: DITCH WITCH® EQUIPMENT AND REPLACEMENT PARTS LIMITED WARRANTY POLICY

Subject to the limitation and exclusions herein, free replacement parts will be provided at any authorized Ditch Witch dealership for any Ditch Witch equipment or parts manufactured by The Charles Machine Works, Inc. (CMW) that fail due to a defect in material or workmanship within one (1) year of first commercial use (Exception: 2 years for all SK500 Attachments). Free labor will be provided at any authorized Ditch Witch dealership for installation of parts under this warranty during the first year following "initial commercial" use of the serial numbered Ditch Witch equipment on which it is installed. The customer is responsible for transporting their equipment to an authorized Ditch Witch dealership for all warranty work.

EXCLUSIONS FROM PRODUCT WARRANTY

- All incidental or consequential damages.
- All defects, damages, or injuries caused by misuse, abuse, improper installation, alteration, neglect, or uses other than those for which products were intended.
- All defects, damages, or injuries caused by improper training, operation, or servicing of products in a manner inconsistent with manufacturer's recommendations.
- All engines and engine accessories (these are covered by original manufacturer's warranty).
- Tires, belts, and other parts which are subject to another manufacturer's warranty. (Such warranty will be available to purchaser.)
- ALL IMPLIED WARRANTIES NOT EXPRESSLY STATED HEREIN, INCLUDING ANY WARRANTY OF FITNESS FOR A PARTICULAR PURPOSE AND MERCHANTABILITY.

IF THE PRODUCTS ARE PURCHASED FOR COMMERCIAL PURPOSES, AS DEFINED BY THE UNIFORM COMMERCIAL CODE, THEN THERE ARE NO WARRANTIES WHICH EXTEND BEYOND THE FACE HEREOF AND THERE ARE NO IMPLIED WARRANTIES OF ANY KIND WHICH EXTEND TO A COMMERCIAL BUYER. ALL OTHER PROVISIONS OF THIS LIMITED WARRANTY APPLY INCLUDING THE DUTIES IMPOSED.

Ditch Witch products have been tested to deliver acceptable performance in most conditions. This does not imply they will deliver acceptable performance in all conditions. Therefore, to assure suitability, products should be operated under anticipated working conditions prior to purchase.

Defects will be determined by an inspection within thirty (30) days of the date of failure of the product or part by CMW or its authorized dealer. CMW will provide the location of its inspection facilities or it's nearest authorized dealer upon inquiry. CMW reserves the right to supply remanufactured replacement parts under this warranty as it deems appropriate.

Extended warranties are available upon request from your local Ditch Witch dealer or CMW.

Some states do not allow exclusion or limitation of incidental or consequential damages, so the above limitation or exclusion may not apply. Further, some states do not allow exclusion of or limitation of how long an implied warranty lasts, so the above limitation may not apply. This limited warranty gives product owner specific legal rights and the product owner may also have other rights which vary from state to state.

For information regarding this limited warranty, contact CMW's Product Support Department, P.O. Box 66, Perry, OK 73077-0066, or contact your local Ditch Witch dealer.

CONTENTS

Decals

Decal Location AT/JT3020.....	8
-------------------------------	---

Engine Components

Battery - Begins	54
Battery - Ends	52
Battery Cables	56
Cooling System - Deaeration	22
Cooling System - Fan Assembly	20
Cooling System - Plumbing.....	24
Electrical Mounting Center	44
Engine Diagnostic Port	48
Engine Grid Heater	50
Engine Mounts	42
Engine Oil Drain & Filter.....	16
Engine Service Parts	14
Engine Skid Covers	38
Engine Skid Mounting	36
ESID/Radio Module Mounting	46
Exhaust System	26
Front Hood Assembly	30
Front Hood Support	28
Fuel System.....	58
Intake System	18
Rear Controls.....	40
Rear Fixed Hood.....	34
Rear Opening Hood.....	32

Frame Components

Assisted Make-up	62
Carriage	64
Carriage Stops.....	66
Drill Frame Proximity Switches.....	128
Fuel Tank Assembly	110
Grease Cylinder	118
Hose Track	120
Idler Assembly	116
Idler Roller Parts	114
Jaw Inserts.....	108
Pipe Guide	102
Pipe Restraint	130
Pipe Sensor Sub.....	132
Pivot.....	126
Rotating Wrench.....	104
Rotation Gearbox (AT) - Begins.....	86
Rotation Gearbox (AT) - Ends.....	90
Rotation Gearbox (AT) - Ends/Begins	94
Rotation Gearbox (JT) - Begins/Ends.....	78
Rotation Gearbox (JT) - Ends/Begins.....	82
Spindle Drive Assembly (AT) - Begins	74

Frame Components Continued

Spindle Drive Assembly (AT) - Ends	72
Spindle Drive Assembly (JT) - Begins	70
Spindle Drive Assembly (JT) - Ends	68
Stabilizer Cylinder Locks	124
Stabilizers	122
Stationary Wrench	106
Thrust Drive	98
Thrust Drive Gearbox.....	100
Track Group.....	112
Water Swivel.....	76
Work Lights.....	134

Operator's Station

Electrical Strike System.....	152
Gauges	150
Ground Drive Control	154
Left Console.....	142
Left Console – AT/JT Control Panel.....	144
Operator Station Floor.....	140
Operator Station Seat	138
Right Console & Joystick.....	148
Weather Covers	146

Hydraulics

Anchor Hydraulics	246
Anchor Valve - Begins/Ends	244
Anchor Valve - Ends.....	242
Auxiliary Pump Hydraulics.....	206
Centering Cylinder Hydraulics	240
Charge Pressure Hydraulics	212
Charge Pressure Valve	210
Filter & Reservoir Hydraulics	158
Fluid Pump Hydraulics - Begins	264
Fluid Pump Hydraulics - Ends	262
Front Tilt Relief - Begins.....	222
Front Wrench Hydraulics.....	234
Gripper Hydraulics	252
Ground Drive Brake Hydraulics	218
Ground Drive Hydraulics	216
Hose Track Hydraulics (AT)	168
Hose Track Hydraulics	166
Hose Track Mount Hydraulics	164
Hydraulic Cylinder (2.0x1.0)	268
Hydraulic Cylinder (2.0x1.0x9.0)	276
Hydraulic Cylinder (2.0x1.25).....	270
Hydraulic Cylinder (2.0x1.25x40.25).....	278
Hydraulic Cylinder (2.5x1.25).....	272
Hydraulic Cylinder (4.0x2.0)	274

CONTINUED

CONTENTS

Hydraulics Continued

Hydraulic Oil Cooler	162
Hydraulics Reservoir	160
Inner Rotation Hydraulics	174
Inner Rotation Pump Hydraulics	172
Inner Rotation Pump Mount	170
Lubricator Hydraulics	266
Outer Rotation Pump Hydraulics	192
P.O.R. Manifold (AT).....	176
P.O.R. Relief Hydraulics	214
Pipe Life Hydraulics	256
Pipe Loader Valve Hydraulics	250
Pipe Loader Valve.....	248
Pipebox Shuttle Hydraulics	258
Piston Pump Hydraulics - Begins	204
Piston Pump Hydraulics - Ends	202
Pivot Hydraulics	224
Pump Mount - Begins	180
Pump Mount - Ends.....	178
Pump Stack P.O.R. Hydraulics	186
Pump Stack Return - Begins.....	190
Pump Stack Return - Ends.....	188
Pump Stack Suction - Begins	184
Pump Stack Suction - Ends	182
Rear Wrench Hydraulics	236
Rotation Motor Hydraulics - Begins	196
Rotation Motor Hydraulics - Ends.....	194
Selector Valve Hydraulics	208
Set-Up Valve.....	220
Shuttle Hydraulics	254
Spindle Brake Hydraulics	260
Stabilizer Hydraulics.....	226
Thrust Motor Hydraulics	200
Thrust Pump Hydraulics.....	198
Wrench Manifold - Begins.....	230
Wrench Manifold - Ends.....	228
Wrench Manifold Hydraulics	232
Wrench Rotate Hydraulics	238

Electrical

***See Technical Supplement for further Electrical Information**

Anchor Systems

Anchor System	286
Anchors	284
Auto-Luber Assembly.....	292
Lubricator Mount.....	288
Lubricator Nozzle	290

Fluid System

Fluid Pump (Fluid End)	298
Fluid Pump (Power End).....	300
Fluid Pump Assembly.....	296

Pipe Loader System

Pipe Box Shifter Sub	308
Pipe Box Spacer	320
Pipe Lifters	324
Pipe Loader Chutes	314
Pipe Loader Controller Mount.....	316
Pipe Loader Covers	312
Pipe Loader - Misc.	318
Shuttle.....	306
Shuttle Supports.....	310

Cab

AC Components.....	334
AC Fuse Block Mounting.....	342
AC Hydraulics	340
Battery Compartment.....	330
Cab Mounting	324
Cab Service Parts	346
Cab Working Lights	344
Canopy	336
Heater.....	332
Seat	328
Support Arm.....	326
Tool Tray	338

Accessories

Antifreeze Tank	350
AT Pipe Box (Short)	362
AT Pipe Box (Tall)	358
Canopy.....	352
Drilling Fluid Transfer	366
Grounding Hardware	362
Heated Greaser	354
JT Pipe Box (Short).....	360
JT Pipe Box (Tall).....	352

Miscellaneous

Bolt/Nut Torque Chart	370
Filters	374
Optional Kits.....	374
Parts Manual Change Request	375
Related Publications.....	374
Replacement O-Ring Chart	373
Warranty Registration	376

DECALS

DECAL LOCATION AT/JT3020

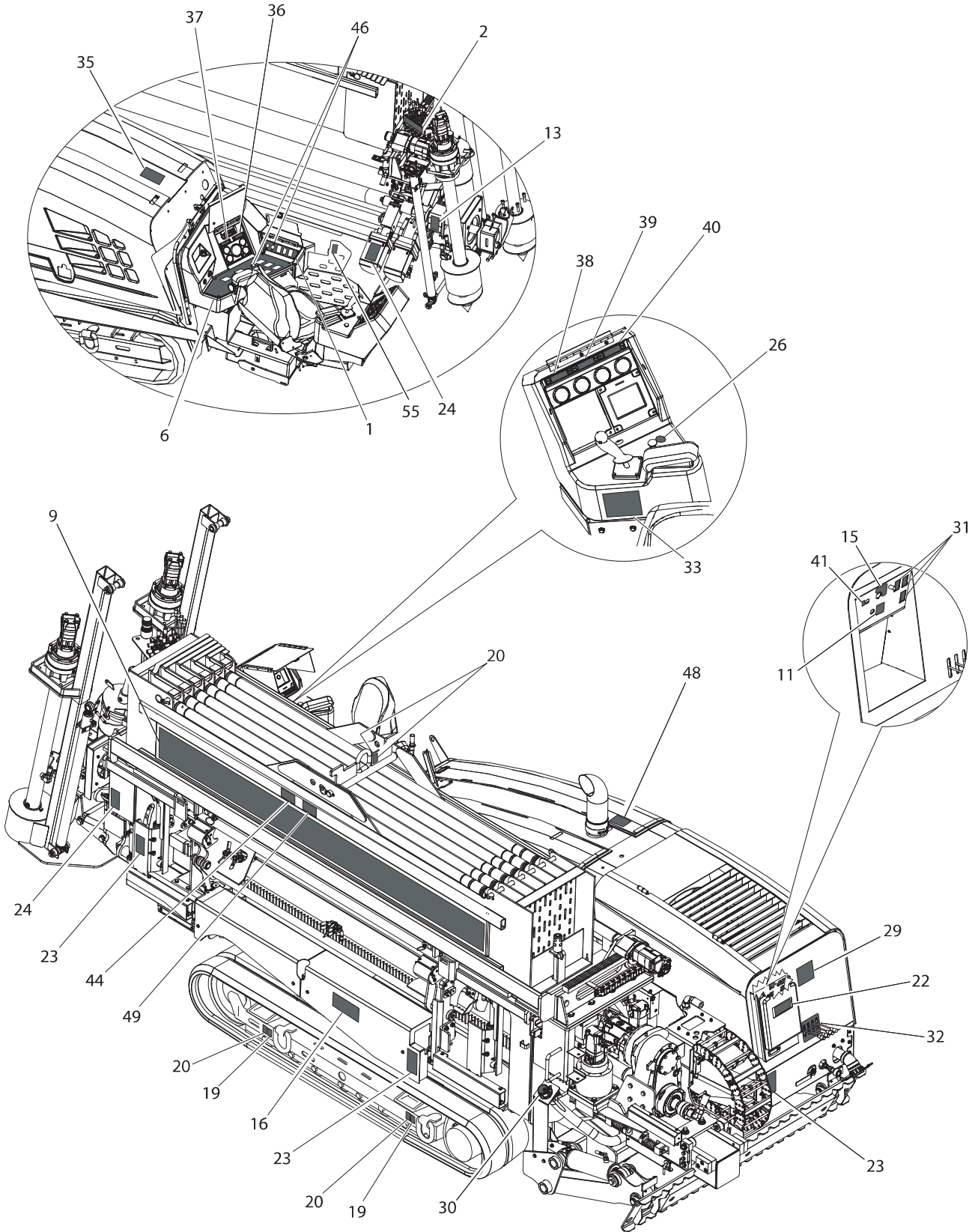

DECAL LOCATION AT/JT3020

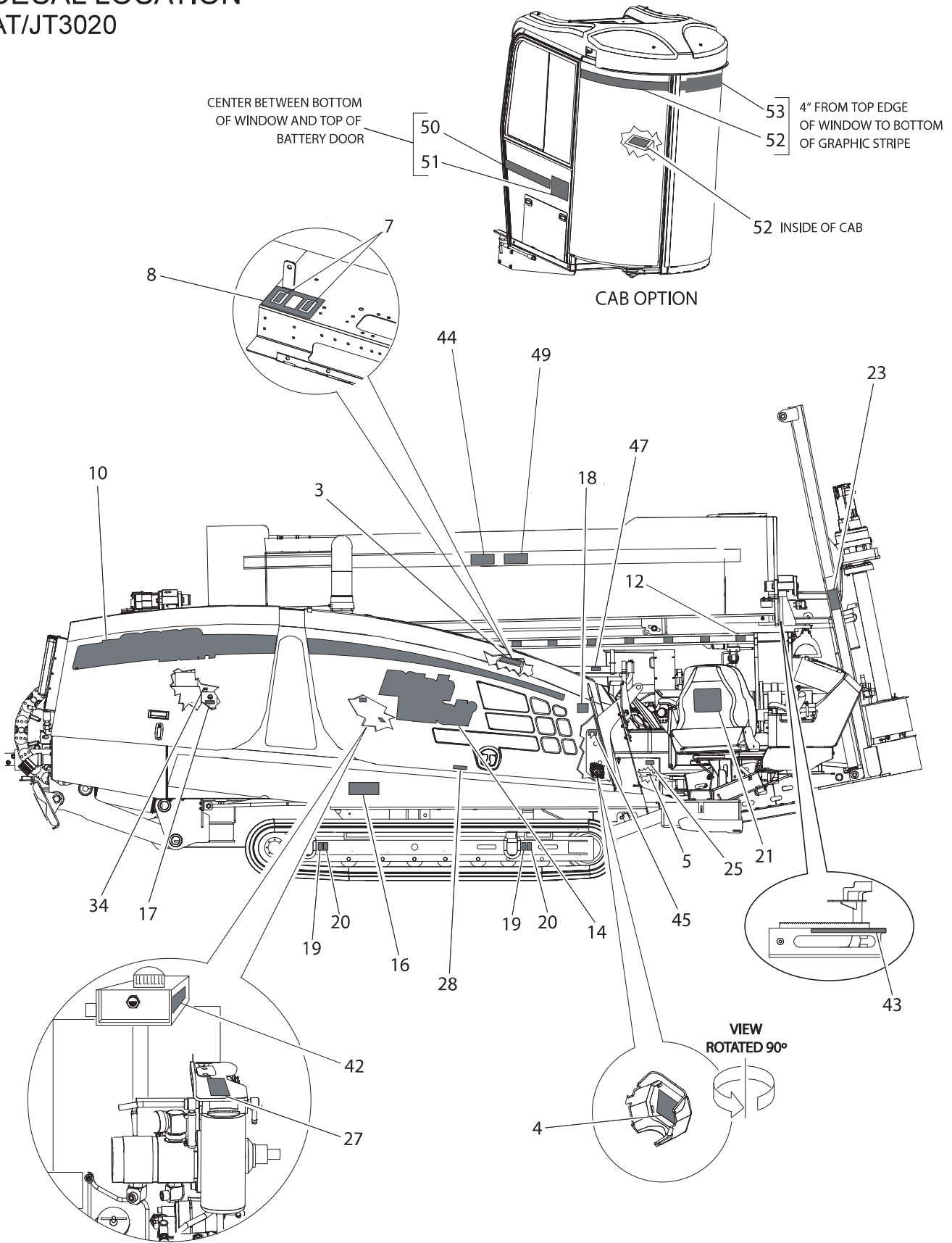

DECAL LOCATION AT/JT3020

REF NO.	PART NUMBER	QTY	DESCRIPTION	REMARKS
	270-I237		DECAL KIT - JT3020	
	270-I236		DECAL KIT - JT3020AT	
I	270-I235	I	JT3020 LEFT CONSOLE PANEL	SEE FOOTNOTE 1
	270-I234	I	JT3020AT LEFT CONSOLE PANEL	SEE FOOTNOTE 2
2	270-I233	I	FRONT ANCHOR	
3	270-I232	I	RELAY PANEL	
4	270-I452	I	FUSE BLOCK	
5	273-267	2	DITCH WITCH BATTERY	
6	270-I229	I	LEFT CONTROL PANEL	
7	270-I228	I	THROTTLE / FAN	
8	270-I227	I	RELAY PANEL SWITCH	
9	270-II61	I	JT3020AT MODEL ID PIPE BOX	SEE FOOTNOTE 2
	270-II60	I	JT3020 MODEL ID PIPE BOX	SEE FOOTNOTE 1
10	270-II59	I	JT3020AT MODEL ID	SEE FOOTNOTE 2
	270-II58	I	JT3020 MODEL ID	SEE FOOTNOTE 1
11	273-I98	I	TRACKER CONTROL	
12	273-444	I	PIPE BOX NUMBERS	
13	273-278	I	DANGER WRENCH	
14	273-434	I	DITCH WITCH	
15	273-482	I	IGNITION SWITCH	
16	274-049	2	DANGER ELECTROCUTION	
17	274-I98	I	NOTICE OIL LEVEL	
18	274-291	I	SOUND POWER	SEE FOOTNOTE 3
19	274-318	4	TIE DOWN LOCATION	
20	274-442	6	LIFT LOCATION	
21	274-854	I	LOGO PLACARD	
22	275-048	I	IMPORTANT SAFETY RULES	
23	275-I84	4	WARNING MOVING PARTS	
24	274-I87	2	DANGER ROTATING SHAFT	
25	275-203	I	BATTERY	
26	275-222	I	ENGINE STOP	
27	275-355	I	CAUTION HOT PARTS	
28	275-400	I	NOTICE OIL LEVEL	
29	275-449	I	DITCH WITCH LOGO PLACARD	
30	700-062	I	DIESEL FUEL CAP	
31	270-I423	I	TRACK SWITCH	
32	270-I424	I	FRAME TILT	
33	700-245	I	RIGHT CONTROL	
34	700-063	I	HYDRAULIC OIL CAP	
35	274-780	I	JET TRAC PATENT	
36	270-I408	I	JT3020 LEFT DISPLAY B	
37	270-I407	I	JT3020 LEFT DISPLAY A	
38	270-I404	I	JT3020 RIGHT DISPLAY A	
39	270-I405	I	JT3020 RIGHT DISPLAY B	
40	270-I406	I	JT3020 RIGHT DISPLAY C	

FOOTNOTES

1. PART OF KIT NUMBER 270-I237.
2. PART OF KIT NUMBER 270-I236.
3. NOT PART OF KIT.

DECAL LOCATION AT/JT3020

REF NO.	PART NUMBER	QTY	DESCRIPTION	REMARKS
41	273-061	1	START ASSIST	
42	270-1504	1	NOTICE COMPLETE FILL	
43	270-1860	1	RACK INDICATOR	
44	275-326	2	WARNING CRUSHING WEIGHT	
45	700-191	1	MASTER DISCONNECT SWITCH	
46	274-940	1	INDICATOR DECAL	USED WITH JT3020
	274-940	2	INDICATOR DECAL	USED WITH JT3020AT
47	273-128	1	NO STEP	
48	273-459	1	WARNING EXPLOSION	
49	701-326	2	WARNING CRUSHING WEIGHT (ISO)	
50	274-874	1	GRAPHIC STRIPE (SOLD PER INCH)	USE 38"; USED WITH CAB OPTION SEE FOOTNOTE 3
51	274-853	1	DITCH WITCH LOGO	USED WITH CAB OPTION SEE FOOTNOTE 3
52	270-2307	1	PERFORATED STRIPE	USED WITH CAB OPTION SEE FOOTNOTE 3
53	270-2306	1	PERFORATED DW LOGOTYPE	USED WITH CAB OPTION SEE FOOTNOTE 3
54	270-4471	1	HEAT AND A/C CONTROL	USED WITH CAB OPTION SEE FOOTNOTE 3
55	273-546	1	WARNING MOVING PARTS	

FOOTNOTES

1. PART OF KIT NUMBER 270-1237.
2. PART OF KIT NUMBER 270-1236.
3. NOT PART OF KIT.

NOTES:

ENGINE COMPONENTS

ENGINE SERVICE PARTS

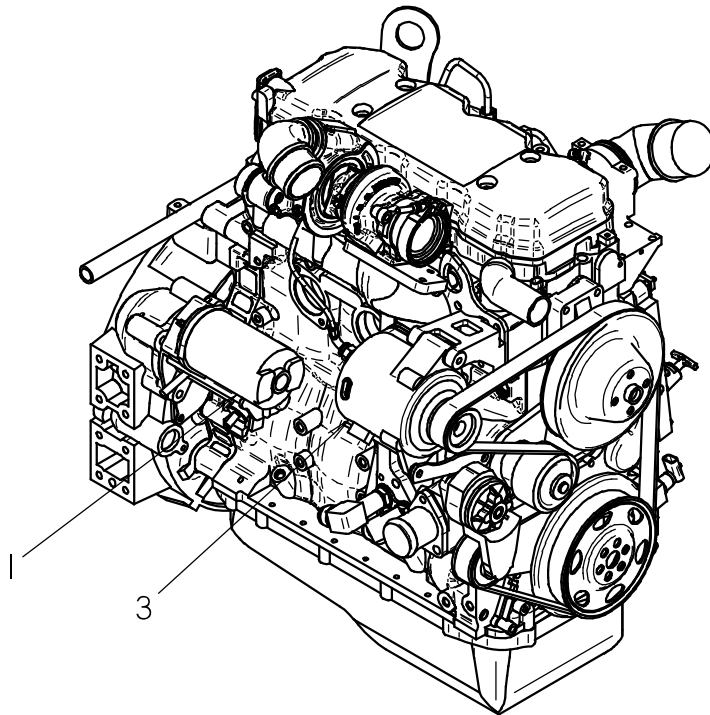
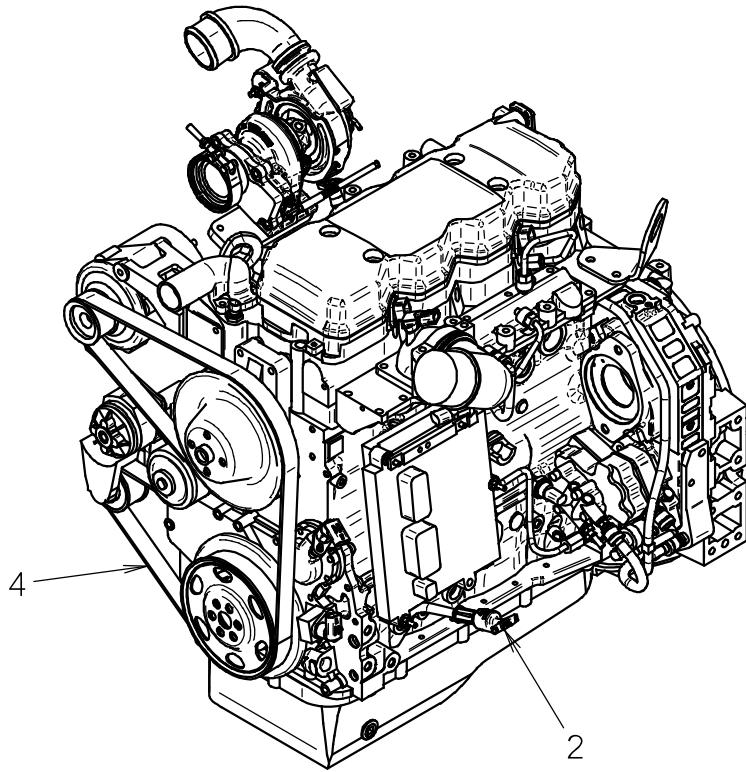

ENGINE SERVICE PARTS

REF NO.	PART NUMBER	QTY	DESCRIPTION	REMARKS
1	195-1079	1	STARTER	
2	195-1075	1	OIL DIPSTICK	
3	195-1078	1	ALTERNATOR	SEE FOOTNOTE 1
4	195-1076	1	FAN BELT	

NOT SHOWN:

195-1077	1	THERMOSTAT	
215-1105	1	BRAIDED GROUND STRIP	
215-1220	1	ALTERNATOR POWER CABLE	TO ALTERNATOR BAT + TO ALTERNATOR FUSE
215-1101	1	ALTERNATOR GROUND CABLE	TO ALTERNATOR GROUND POST TO ENGINE BLOCK
106-654	1	SCREW (M10-1.50 X 16MM)	USE WITH 110-332
110-332	1	BOLT-ON CLAMP (1 5/8")	USED FOR WIRING HARNESS ON ENGINE BLOCK BY STARTER

FOOTNOTES:

1. SERVICE PART 215-1461 130A ALTERNATOR USED WITH CAB OPTION

NOTE:

ENGINE OIL DRAIN AND FILTER

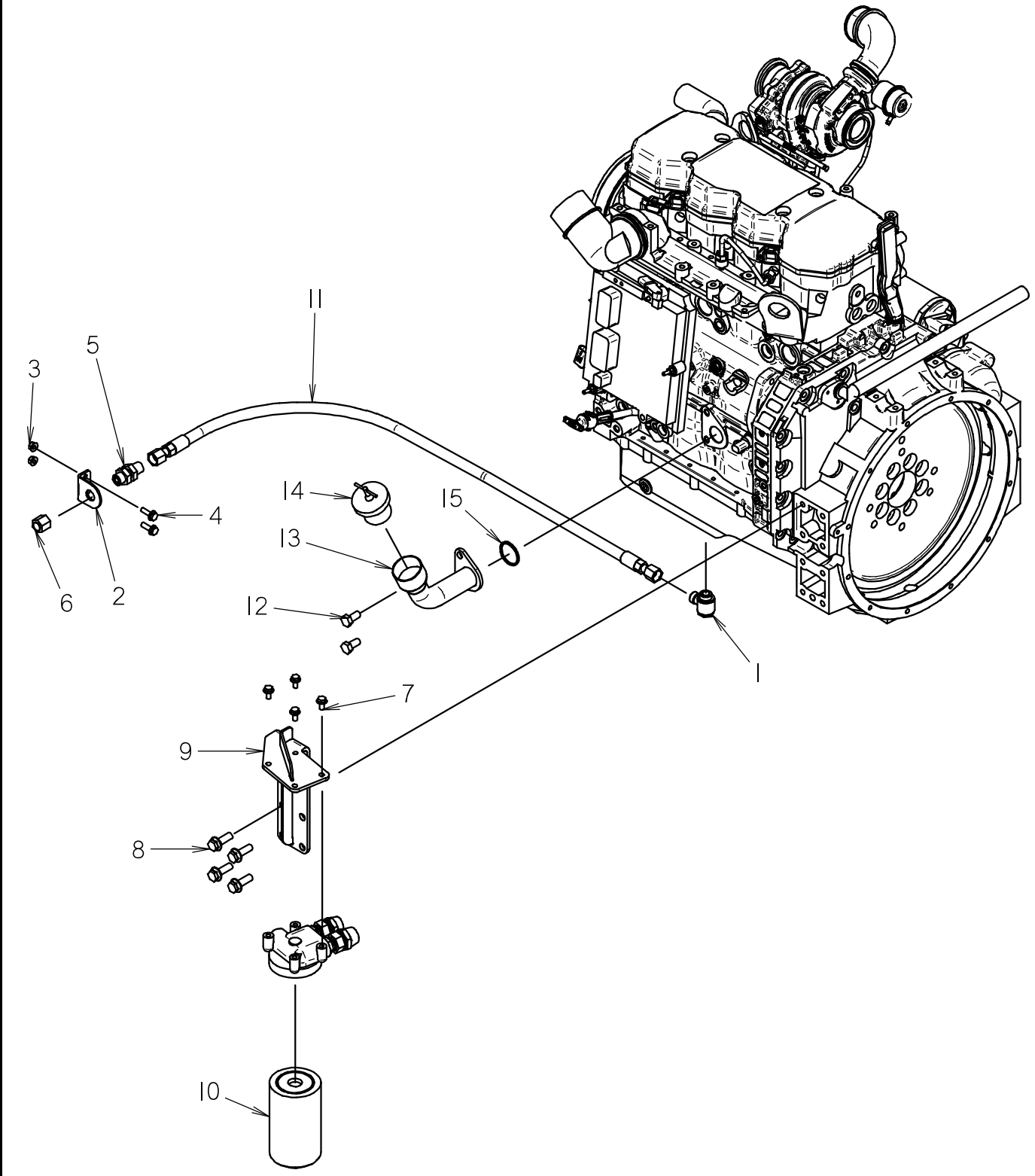

ENGINE OIL DRAIN AND FILTER

REF NO.	PART NUMBER	QTY	DESCRIPTION	REMARKS
1	157-445	1	BANJO FITTING (M22)	
2	300-1495	1	BRACKET	
3	106-386	2	FLG LOCKNUT (M8-1.25)	
4	106-381	2	FLG LK SCREW (M8-1.25 X 25MM)	
5	154-390	1	BK CONNECTOR (080)	
6	154-327	1	CAP (080F)	
7	106-380	4	FLG LK SCREW (M8-1.25 X 16MM)	USE LOCTITE 242 OR EQUIVALENT
8	106-496	4	FLG SCREW (M12-1.75 X 35MM)	USE LOCTITE 242 OR EQUIVALENT (TORQUE TO 80 ft-lbs)
9	300-2013	1	FILTER MOUNT	
10	195-1034	1	FILTER, ENGINE OIL	
11	154-745	1	HOSE (080FX-50"-3000)	
12	106-559	2	SCREW (M12-1.75 X 25MM)	
13	195-1126	1	OIL FILL	
14	195-1074	1	ENGINE OIL FILL CAP	
15	150-1666	1	SQUARE RING	

NOT SHOWN:

FOOTNOTES:

NOTE:

INTAKE SYSTEM

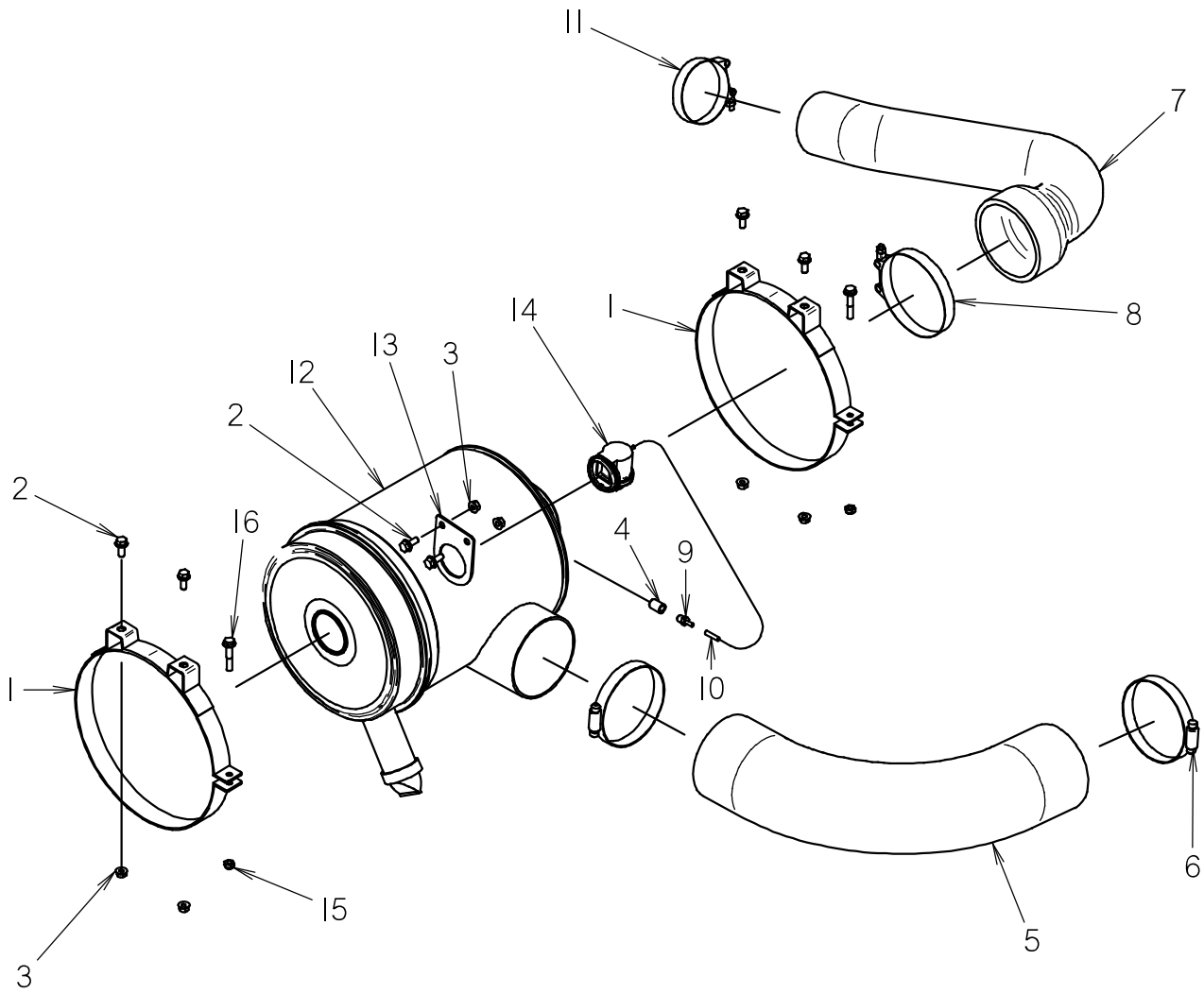

INTAKE SYSTEM

REF NO.	PART NUMBER	QTY	DESCRIPTION	REMARKS
1	318-722	2	MOUNTING CLAMP 11"	
2	106-162	6	FLG SCREW (M8-1.25 X 20MM, GD8)	
3	106-386	6	FLG LOCKNUT (M8-1.25)	
4	115-172	1	COLLAR (02NF-02NF)	
5	118-489	1	AIR INTAKE HOSE	
6	110-391	2	WORM CLAMP (4-3/4" TO 5-5/8")	
7	118-427	1	INTAKE HOSE	
8	105-1046	1	T-BOLT CLAMP (5.00-5.31)	
9	155-150	1	S/O COUPLER (02N-02H)	
10	116-192	11	BULK HOSE (7/64", SOLD PER 1")	USE 1 @ 11"
11	105-1047	1	T-BOLT CLAMP (3.50-3.81)	
12	194-871	1	AIR FILTER ASSEMBLY (11")	SEE FOOTNOTE 1
13	300-3333	1	BRACKET	
14	258-067	1	RESTRICTION INDICATOR(25",H20)	
15	107-096	2	LOCKNUT (M8-1.25, NLK)	
16	106-200	2	FLG LK SCREW (M8-1.25 X 45MM)	

NOT SHOWN:

FOOTNOTES:

- 1. 195-1040 AIR FILTER (PRIMARY)
- 195-1041 AIR FILTER (SECONDARY)
- 194-761 VACUATOR VALVE

NOTE:

COOLING SYSTEM - FAN ASSEMBLY

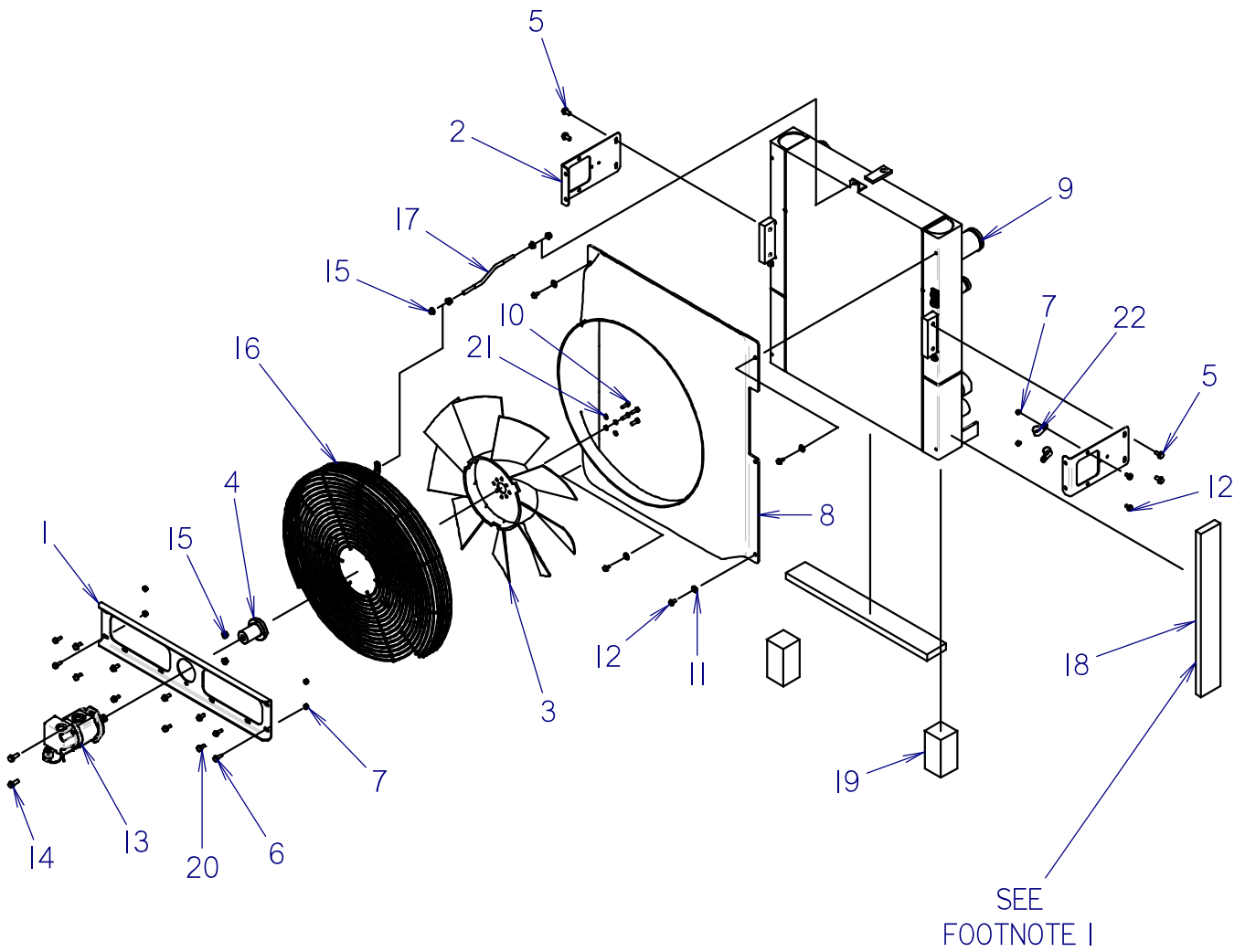

COOLING SYSTEM - FAN ASSEMBLY

REF NO.	PART NUMBER	QTY	DESCRIPTION	REMARKS
1	327-801	1	FAN MOUNT PLATE	
2	327-800	2	END PLATE	
3	194-134	1	FAN (26.0" OD, 2.50" BC)	
4	194-1000	1	FAN HUB	
5	106-382	4	FLG LK SCREW (M10-1.50 X 20MM)	
6	106-381	4	FLG LK SCREW (M8-1.25 X 25MM)	
7	106-386	6	FLG LOCKNUT (M8-1.25)	
8	363-722	1	FAN SHROUD	
9	194-841	1	COOLER	
10	105-806	4	SCREW (M8-1.25 X 25MM)	TORQUE TO 20 FT-LBS
11	105-117	6	WASHER (5/16")	
12	106-380	8	FLG LK SCREW (M8-1.25 X 16MM)	
13	150-1051	1	HYDRAULIC MOTOR	SEE NOT SHOWN PARTS, SEE FOOTNOTE 2
14	106-164	2	FLG LK SCREW (M10-1.50 X 30MM)	
15	106-387	6	FLG LOCKNUT (M10-1.50)	
16	195-1045	1	FAN GUARD	
17	300-2952	1	CONNECTING ROD	
18	362-1055	2	AIR BARRIER	SEE FOOTNOTE 1
19	362-1084	2	AIR BARRIER	
20	106-162	8	FLG SCREW (M8-1.25 X 20MM, GD8)	
21	105-091	4	LOCK WASHER (5/16")	
22	110-333	2	BOLT-ON CLAMP (1")	

NOT SHOWN:

105-206	-	NUT (1/2-NF)	REPLACEMENT PART; TORQUE TO 80 FT-LBS
105-070	-	LOCKWASHER (1/2")	REPLACEMENT PART

FOOTNOTES:

- CUT SIDE BARRIER INTO TWO EQUAL PIECES AND INSTALL ON LEFT AND RIGHT SIDE OF COOLER
- | | | | |
|----------|---|---------------------------|--------------|
| 500-1316 | - | SEAL KIT | |
| 500-1317 | - | SOLENOID | PROPORTIONAL |
| 500-1318 | - | PROPORTIONAL RELIEF VALVE | |
| 500-1319 | - | SPEED SENSOR ASSEMBLY | |

NOTE:

COOLING SYSTEM-DEAERATION

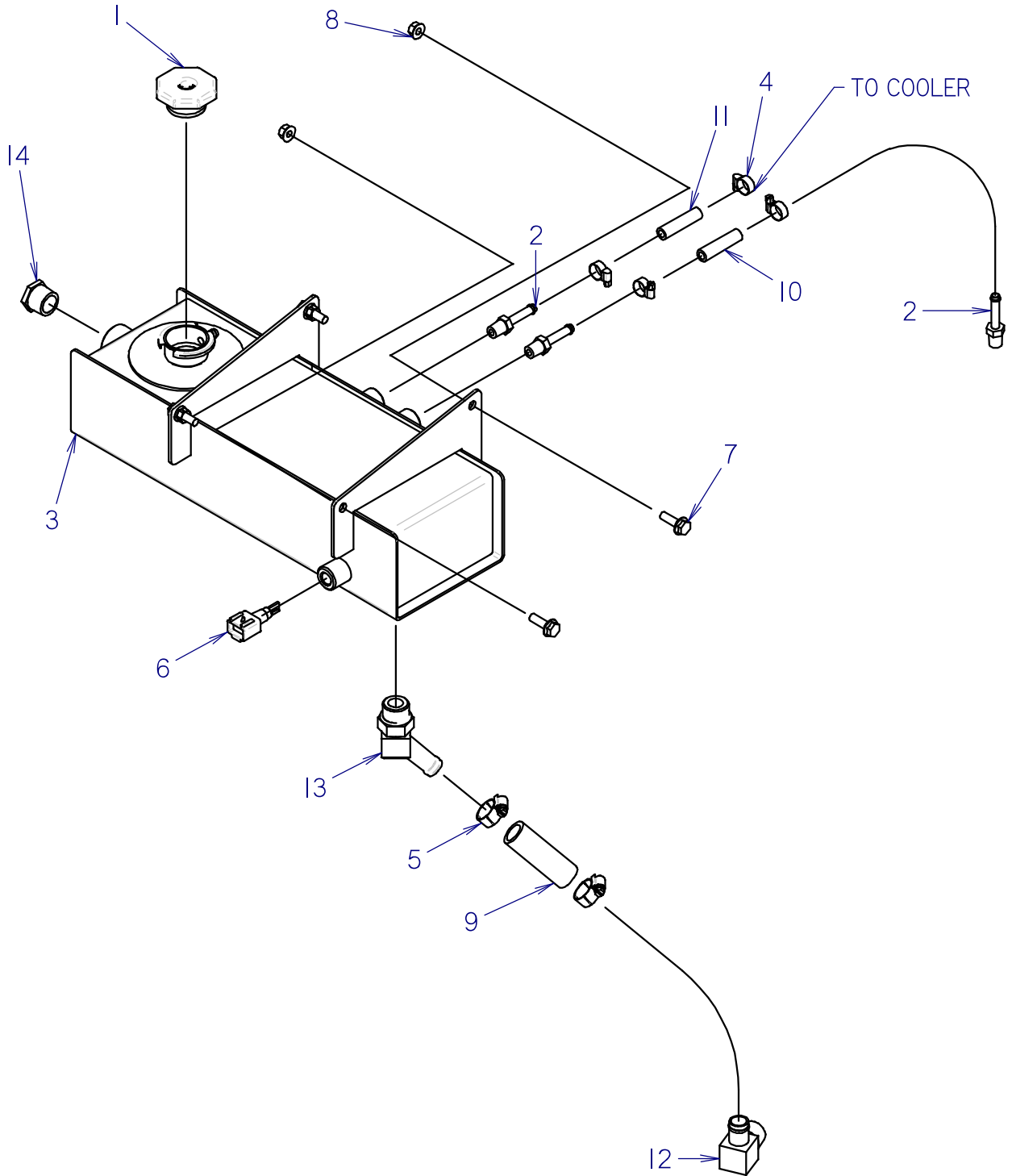

COOLING SYSTEM-DEAERATION

REF NO.	PART NUMBER	QTY	DESCRIPTION	REMARKS
1	111-084	1	RADIATOR CAP (16 PSI)	
2	155-162	3	S/O COUPLER (04N-05H)	
3	364-723	1	EXPANSION TANK	
4	110-249	4	WORM CLAMP (1/4" TO 5/8")	
5	110-217	2	WORM CLAMP (7/16" TO 1")	
6	213-366	1	COOLANT LEVEL SWITCH	
7	106-381	4	FLG LK SCREW (M8-1.25 X 25MM)	
8	106-386	4	FLG LOCKNUT (M8-1.25)	
9	116-751	24	BULK HOSE (3/4",SOLD PER FT)	
10	116-108	18	BULK HOSE (5/16", SOLD PER 1')	
11	116-108	33	BULK HOSE (5/16", SOLD PER 1')	
12	150-1242	1	S/O COUPLER (12N-12H90, SHORT)	
13	155-196	1	S/O COUPLER (12S-12H45)	
14	110-549	1	SIGHT GAUGE (12N)	

NOT SHOWN:

FOOTNOTES:

NOTE:

COOLING SYSTEM - PLUMBING

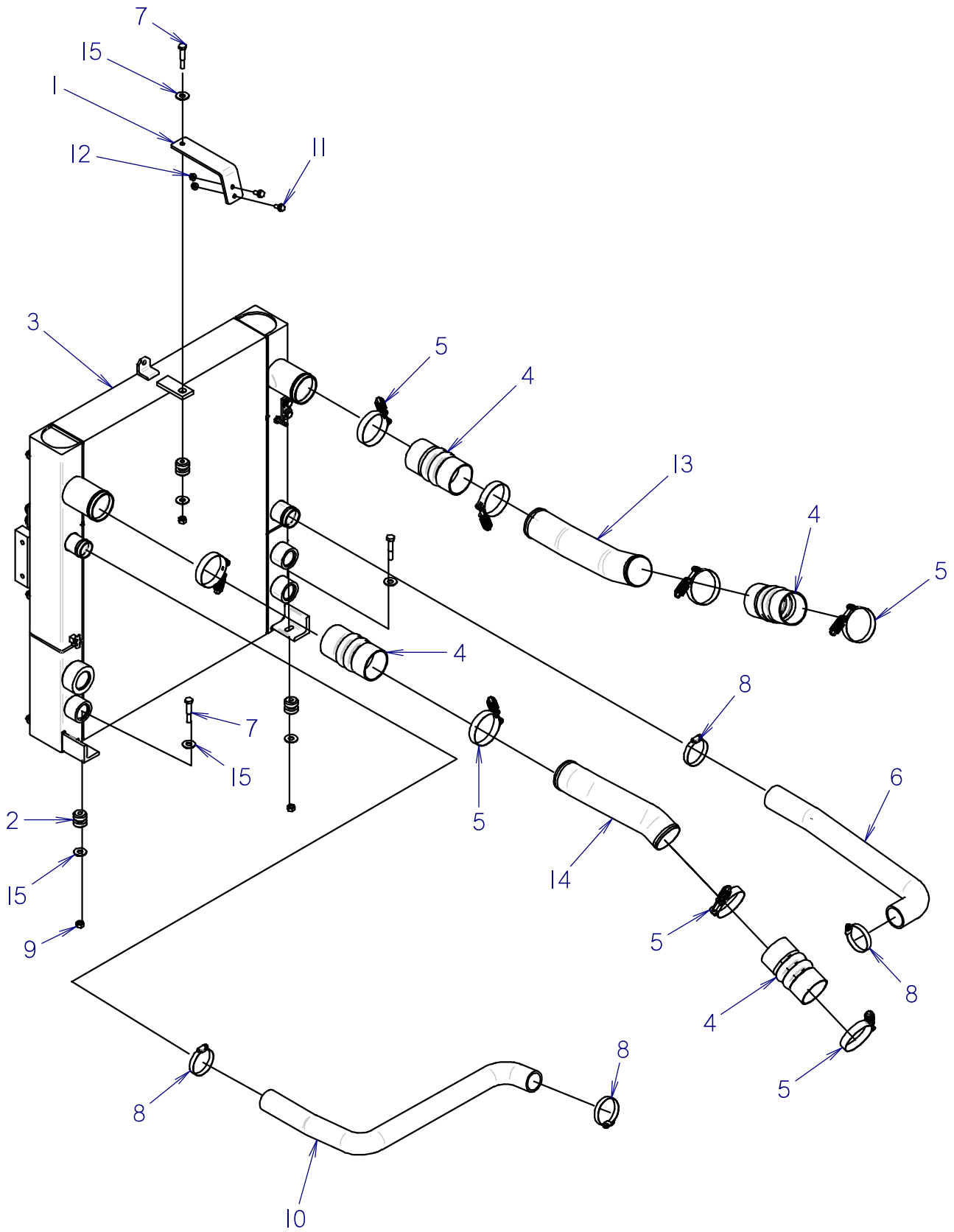

COOLING SYSTEM - PLUMBING

REF NO.	PART NUMBER	QTY	DESCRIPTION	REMARKS
1	327-883	1	RADIATOR BRACKET	
2	116-128	3	SHOCK MOUNT	
3	194-841	1	COOLER	
4	116-703	4	CHARGE AIR COOLER HOSE	
5	118-490	8	T-BOLT CLAMP (3.06" TO 3.30")	
6	118-422	1	LOWER RADIATOR HOSE	
7	106-628	3	SCREW (M10-1.50 X 60MM)	
8	110-134	4	WORM CLAMP (2.062" TO 2.750")	
9	105-894	3	LOCKNUT(M10-1.50,PRV TRQ,10.9)	
10	118-423	1	UPPER RADIATOR HOSE	
11	106-162	2	FLG SCREW (M8-1.25 X 20MM, GD8)	
12	106-386	2	FLG LOCKNUT (M8-1.25)	
13	158-259	1	CHARGE AIR TUBE (-48)	
14	158-258	1	CHARGE AIR TUBE (-48)	
15	105-059	6	WASHER (7/16")	

NOT SHOWN:

FOOTNOTES:

NOTE:

EXHAUST SYSTEM

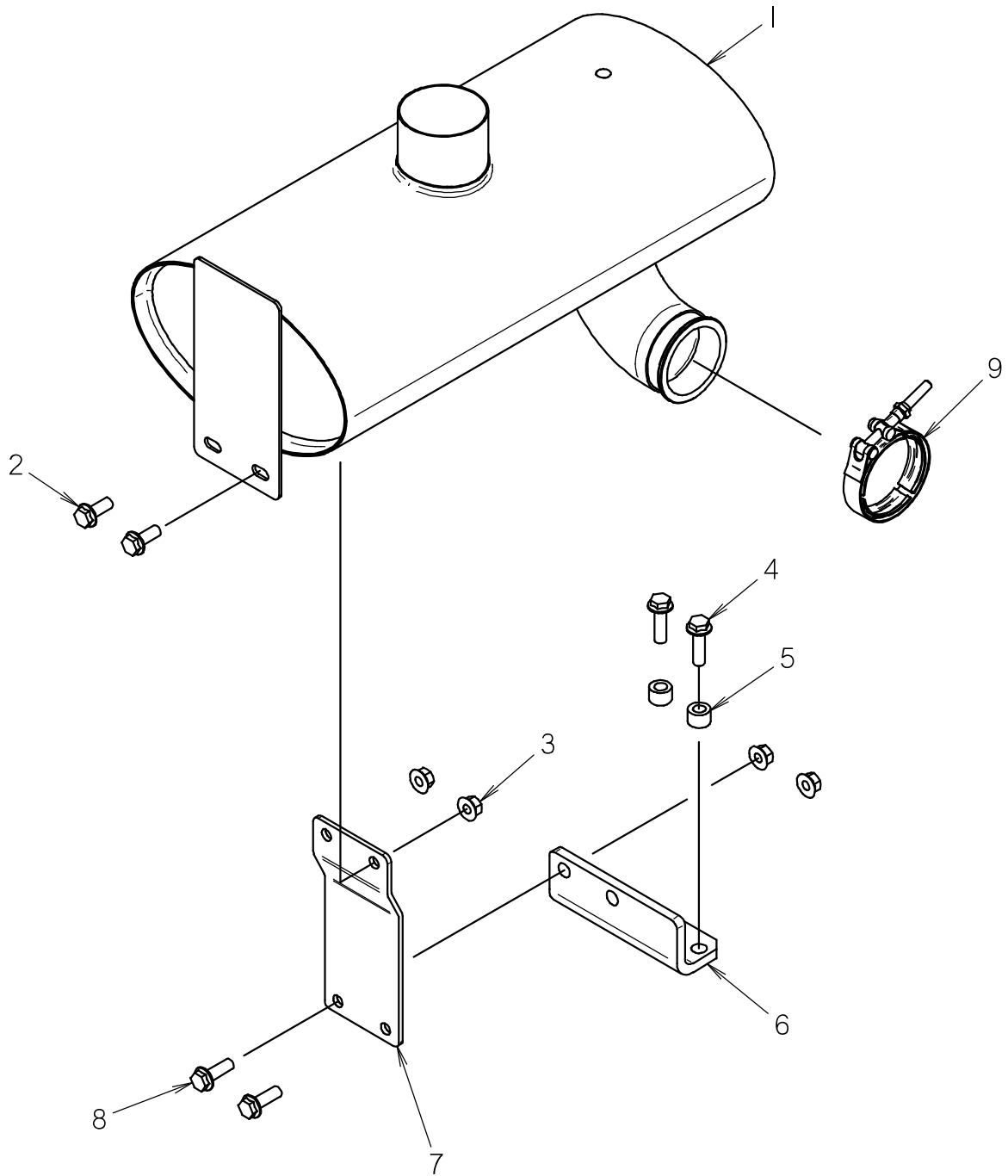

EXHAUST SYSTEM

REF NO.	PART NUMBER	QTY	DESCRIPTION	REMARKS
1	194-855	1	MUFFLER	
2	106-724	2	FLG SCREW (M10-1.50 X 25MM)	USE LOCTITE 242 OR EQUIVALENT
3	106-387	4	FLG LOCKNUT (M10-1.50)	
4	106-497	2	FLG SCREW (M10-1.50 X 35MM)	USE LOCTITE 242 OR EQUIVALENT TORQUE TO 25 FT-LBS
5	184-569	2	SPACER	
6	300-2961	1	BRACKET	
7	300-2962	1	BRACKET	
8	106-383	2	FLG LK SCREW (M10-1.50 X 30MM)	USE LOCTITE 242 OR EQUIVALENT
9	118-318	1	V-BAND CLAMP (2-3/4")	

NOT SHOWN:

FOOTNOTES:

NOTE:

FRONT HOOD SUPPORT

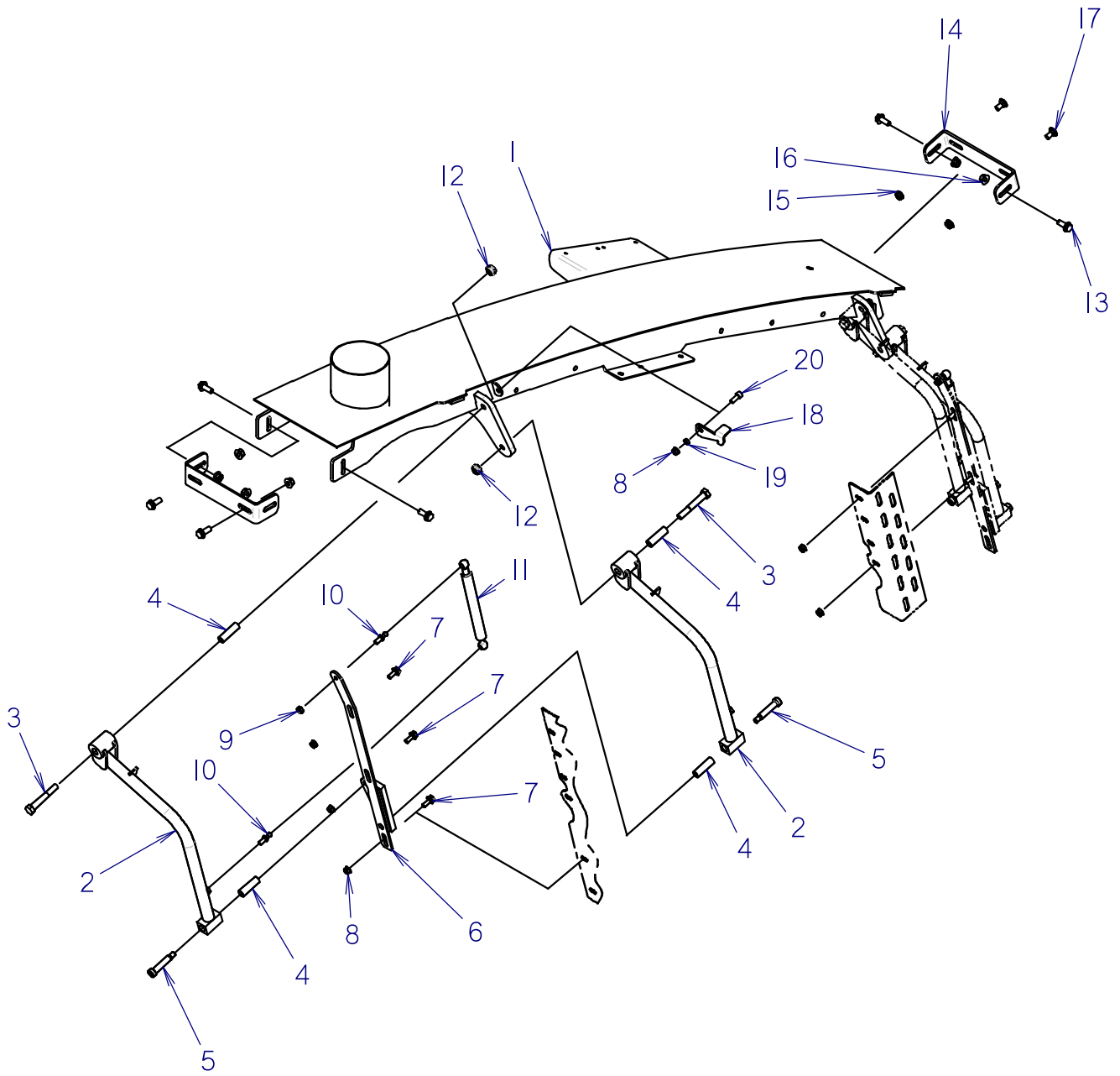

FRONT HOOD SUPPORT

REF NO.	PART NUMBER	QTY	DESCRIPTION	REMARKS
1	327-174	1	FRONT HOOD SUPPORT	
2	327-172	2	ARM	SEE NOTE 1
3	106-700	2	SCREW (M12-1.75 X 80MM)	SEE NOTE 1
4	179-832	4	SLEEVE	SEE NOTE 1
5	106-971	2	SHLD BLT (M12 X 50MM,M10-1.50)	SEE NOTE 1
6	327-187	1	HOOD BRACKET	SEE NOTE 1
7	106-162	3	FLG SCREW (M8-1.25 X 20MM, GD8)	SEE NOTE 2
8	106-386	4	FLG LOCKNUT (M8-1.25)	SEE NOTE 2
9	105-089	1	LOCKNUT (5/16-NC)	SEE NOTE 1
10	110-655	2	BALL SCREW (5/16-NC X 1/2")	SEE NOTE 1
11	151-227	1	GAS STRUT	SEE NOTE 1
12	106-031	2	LOCKNUT (M12-1.75, NLK)	SEE NOTE 1
13	105-799	6	FLG LK SCREW (M10-1.50 X 25MM)	
14	327-441	2	BRACKET	
15	105-834	2	FLG LOCKNUT (3/8-NC)	
16	106-266	6	FLG NUT (M10-1.50)	
17	105-835	2	CARRIAGE BOLT (3/8-NC X 3/4")	
18	300-1096	1	LATCH	
19	179-593	1	BUSHING	
20	105-842	1	SCREW (M8-1.25 X 20MM, SOC)	

NOT SHOWN:

FOOTNOTES:

NOTE:

- QTY IS PER ASSEMBLY; 2 ASSEMBLIES (FRONT AND REAR)
- QTY OF 3 FOR REAR ASSEMBLY; QTY OF 2 FOR FRONT ASSEMBLY

FRONT HOOD ASSEMBLY

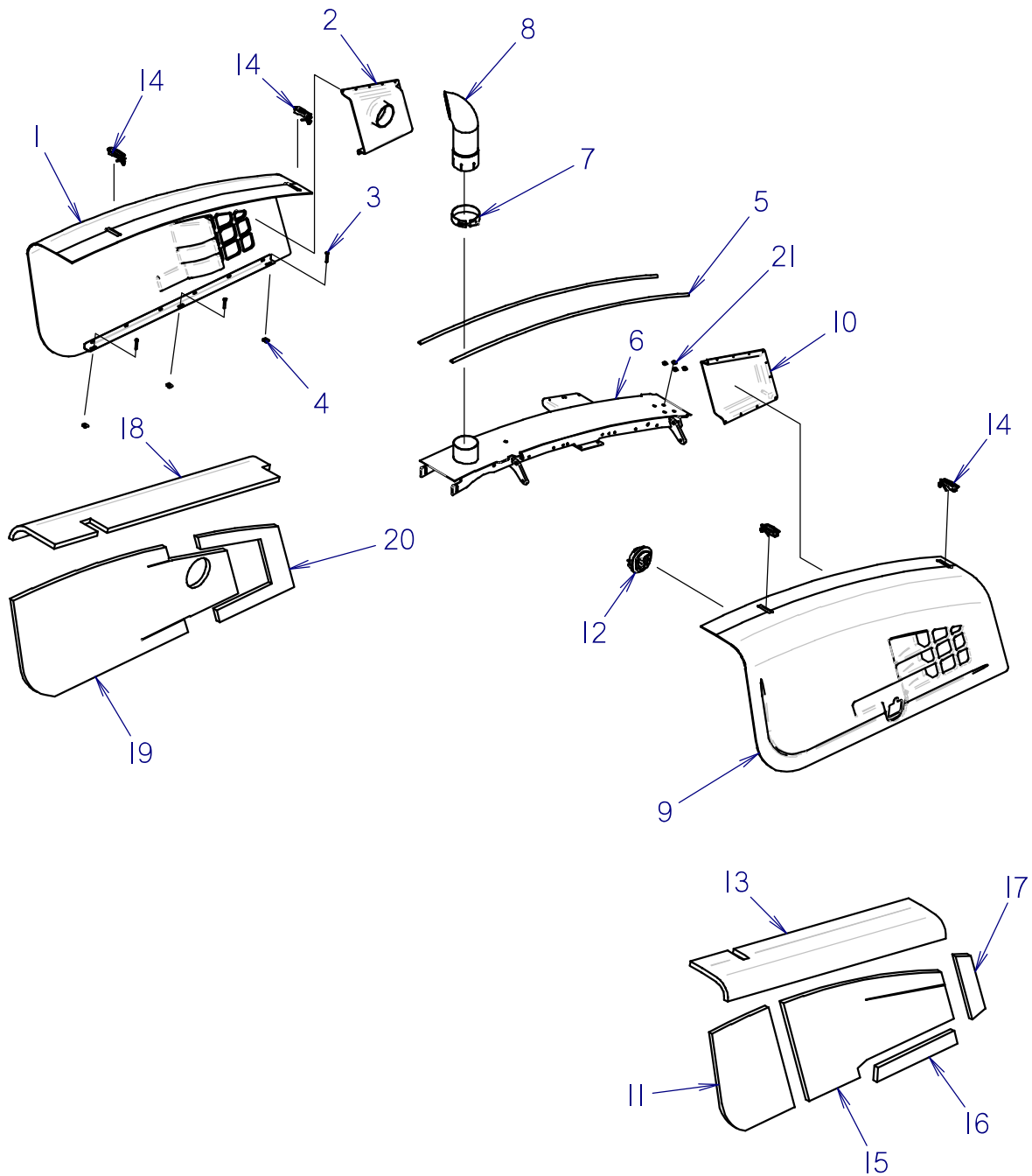

FRONT HOOD ASSEMBLY

REF NO.	PART NUMBER	QTY	DESCRIPTION	REMARKS
1	329-425	1	FRONT FIXED HOOD	
2	329-427	1	AIR BAFFLE	BOND TO 329-425 WITH MP55305
3	106-892	3	SCREW (M8-1.25 X 50MM)	
4	106-551	3	CLIP NUT (M8-1.25)	
5	118-183	142	BULD EDGE (SOLD BY FOOT)	2 @ 71"
6	327-174	1	FRONT HOOD SUPPORT	
7	194-202	1	EXHAUST CLAMP (5-1/2")	
8	194-152	1	EXHAUST	
9	329-428	1	FRONT MOVING HOOD ASSEMBLY	
10	362-1018	1	AIR BAFFLE	BOND TO 329-428 WITH MP55305
11	362-1002	1	SOUND INSULATION	
12	105-1017	1	3 POINT COMPRESSION LATCH	
13	362-1012	1	SOUND INSULATION	
14	117-558	4	LATCH, ADJUST LEVER (LOCKING)	
15	362-1011	1	SOUND INSULATION	
16	362-1014	1	SOUND INSULATION	
17	362-1013	1	SOUND INSULATION	
18	362-1005	1	SOUND INSULATION	
19	362-1003	1	SOUND INSULATION	
20	362-1004	1	SOUND INSULATION	
21	110-776	4	CAPLUG (1/2")	

NOT SHOWN:

FOOTNOTES:

NOTE:

REAR OPENING HOOD

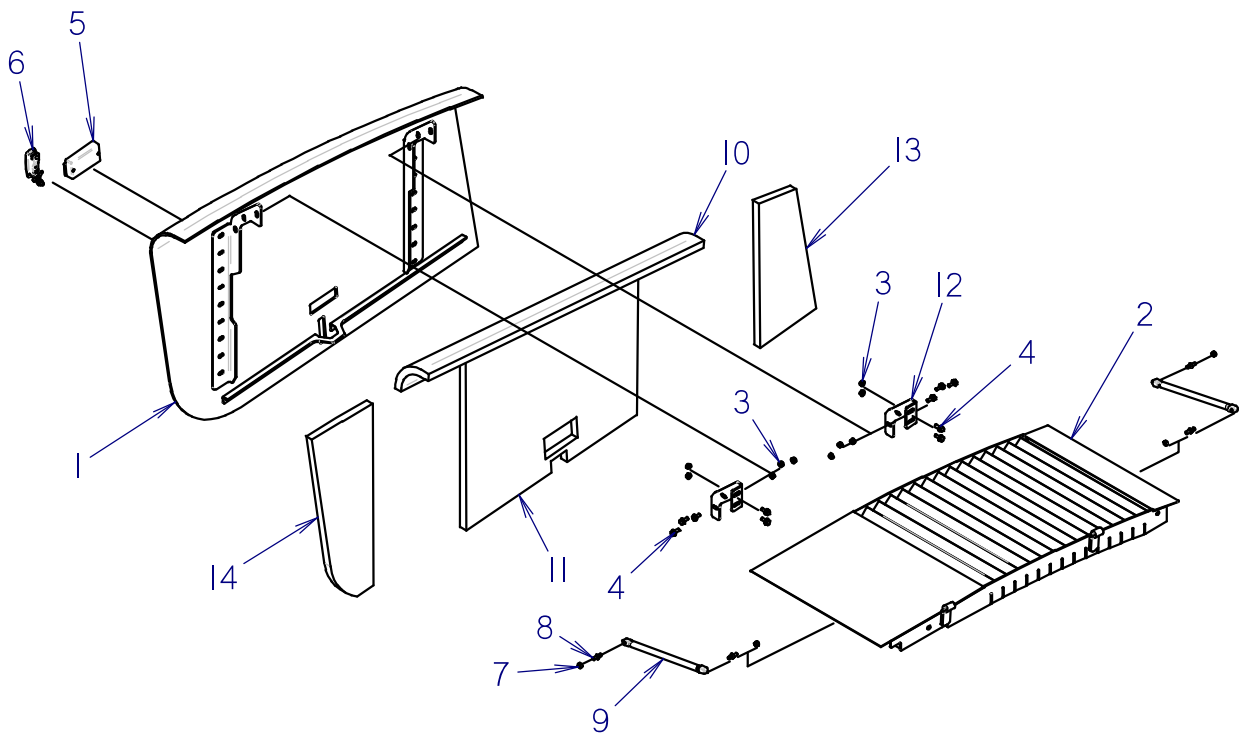

REAR OPENING HOOD

REF NO.	PART NUMBER	QTY	DESCRIPTION	REMARKS
1	329-424	1	REAR MOVING HOOD ASSEMBLY	
2	329-747	1	GRILLE	
3	106-386	10	FLG LOCKNUT (M8-1.25)	
4	106-162	10	FLG SCREW (M8-1.25 X 20MM, GD8)	
5	117-427	1	POCKET PULL HANDLE	
6	117-558	1	LATCH, ADJUST LEVER (LOCKING)	
7	105-089	4	LOCKNUT (5/16-NC)	
8	110-655	4	BALL SCREW (5/16-NC X 1/2")	
9	105-1078	2	STRUT	
10	362-1007	1	SOUND INSULATION	
11*	362-1006	1	SOUND INSULATION	
12	300-5012	2	BRACKET	
13	362-1172	1	SOUND INSULATION	
14	362-1173	1	SOUND INSULATION	

NOT SHOWN:

FOOTNOTES:

NOTE:

REAR FIXED HOOD

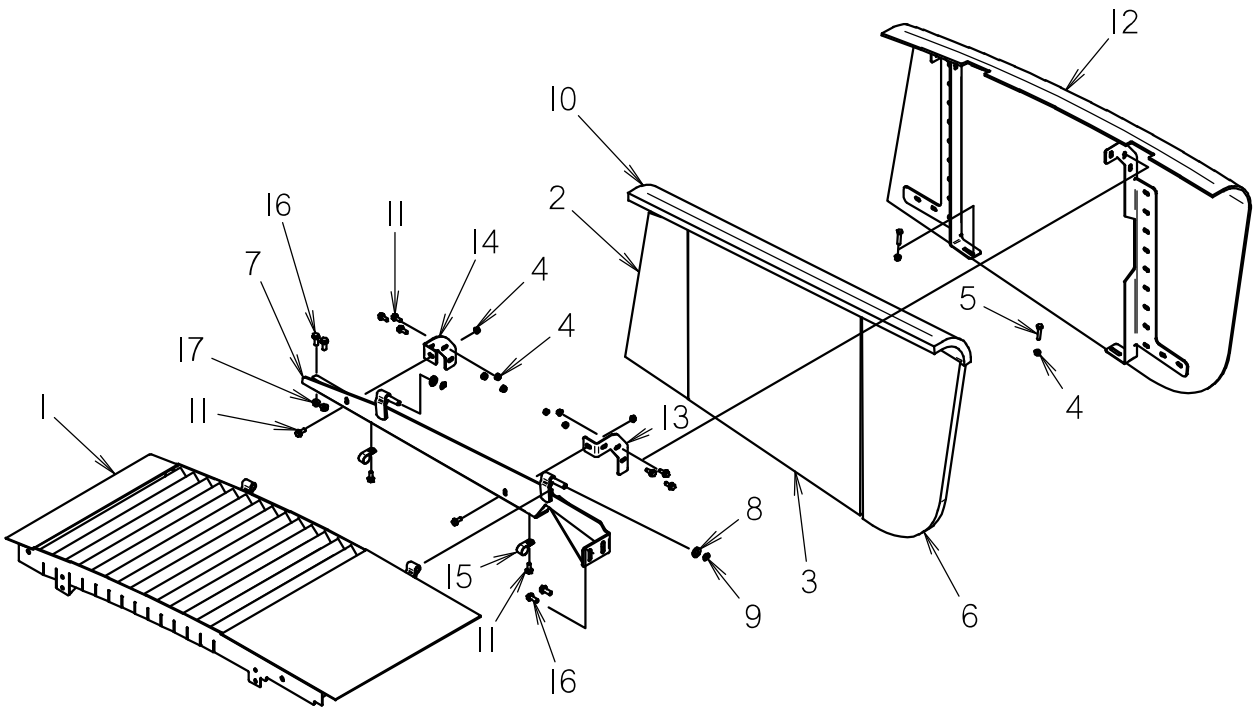

REAR FIXED HOOD

REF NO.	PART NUMBER	QTY	DESCRIPTION	REMARKS
1	329-747	1	GRILLE	
2	362-1010	1	SOUND INSULATION	
3	362-1009	1	SOUND INSULATION	
4	106-386	10	FLG LOCKNUT (M8-1.25)	
5	106-328	2	SCREW (M8-1.25 X 40MM)	
6	362-1008	1	SOUND INSULATION	
7	329-748	1	REAR HOOD SUPPORT	
8	106-397	2	WASHER (M12, HARDENED)	
9	115-482	2	GRIP RING (500")	
10	362-1007	1	SOUND INSULATION	
11	106-162	10	FLG SCREW (M8-1.25 X 20MM, GD8)	
12	329-423	1	REAR FIXED HOOD ASSEMBLY	
13	300-5010	1	BRACKET	
14	300-5011	1	BRACKET	
15	110-333	2	BOLT-ON CLAMP (1")	
16	106-724	4	FLG SCREW (M10-1.50 X 25MM)	
17	106-387	2	FLG LOCKNUT (M10-1.50)	

NOT SHOWN:

FOOTNOTES:

NOTE:

ENGINE SKID MOUNTING

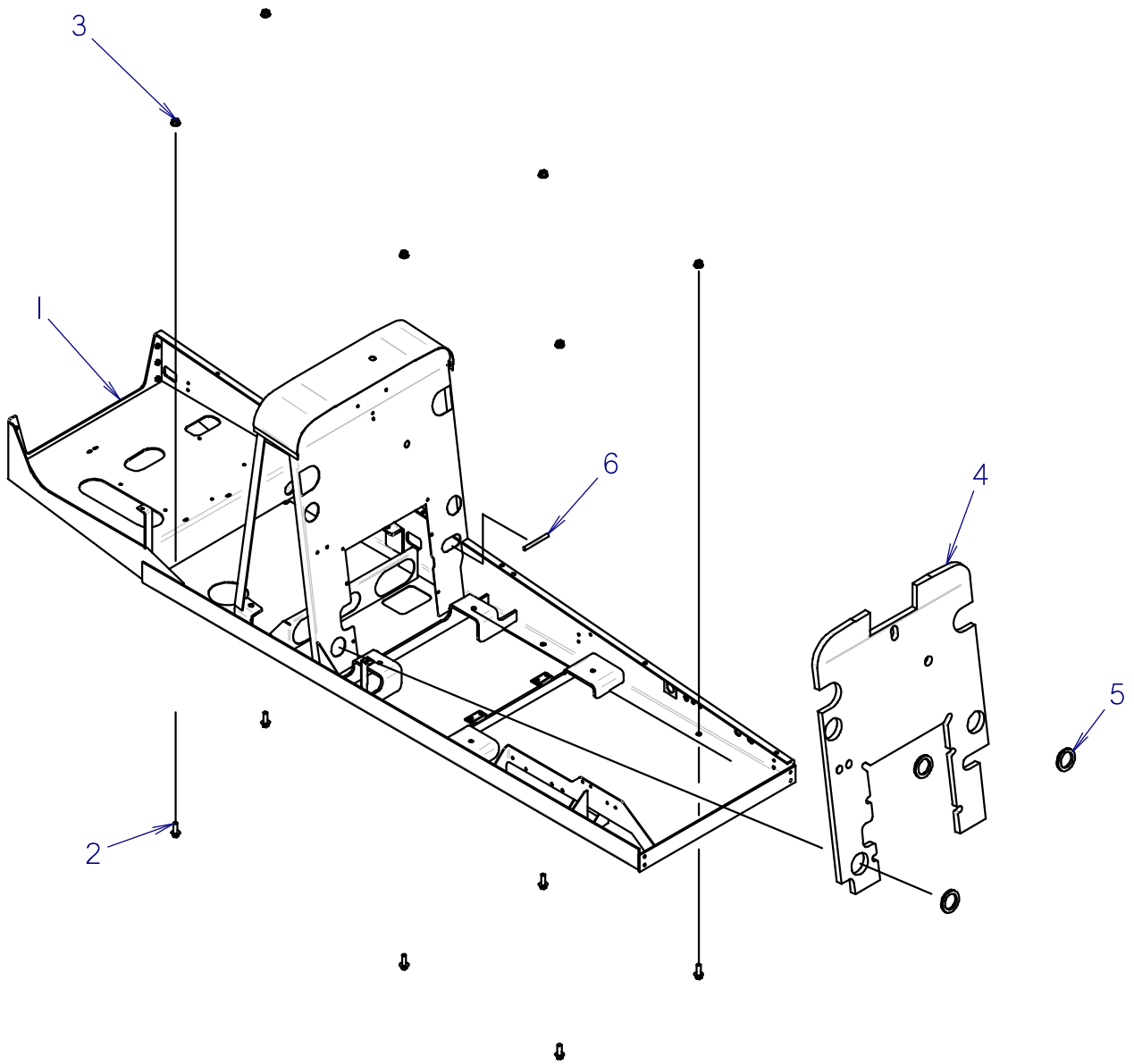

ENGINE SKID MOUNTING

REF NO.	PART NUMBER	QTY	DESCRIPTION	REMARKS
1	327-777	1	ENGINE SKID FRAME	
2	107-336	6	FLG SCREW (M16-2.00X45MM,10.9)	
3	106-355	6	FLG NUT (M16-2.00, 10.9)	
4	362-1015	1	SOUND INSULATION	
5	105-1050	3	GROMMET (2-1/2")	
6	115-686	11	BULK EDGE (5/32",SOLD PER 1')	

NOT SHOWN:

FOOTNOTES:

NOTE:

ENGINE SKID COVERS

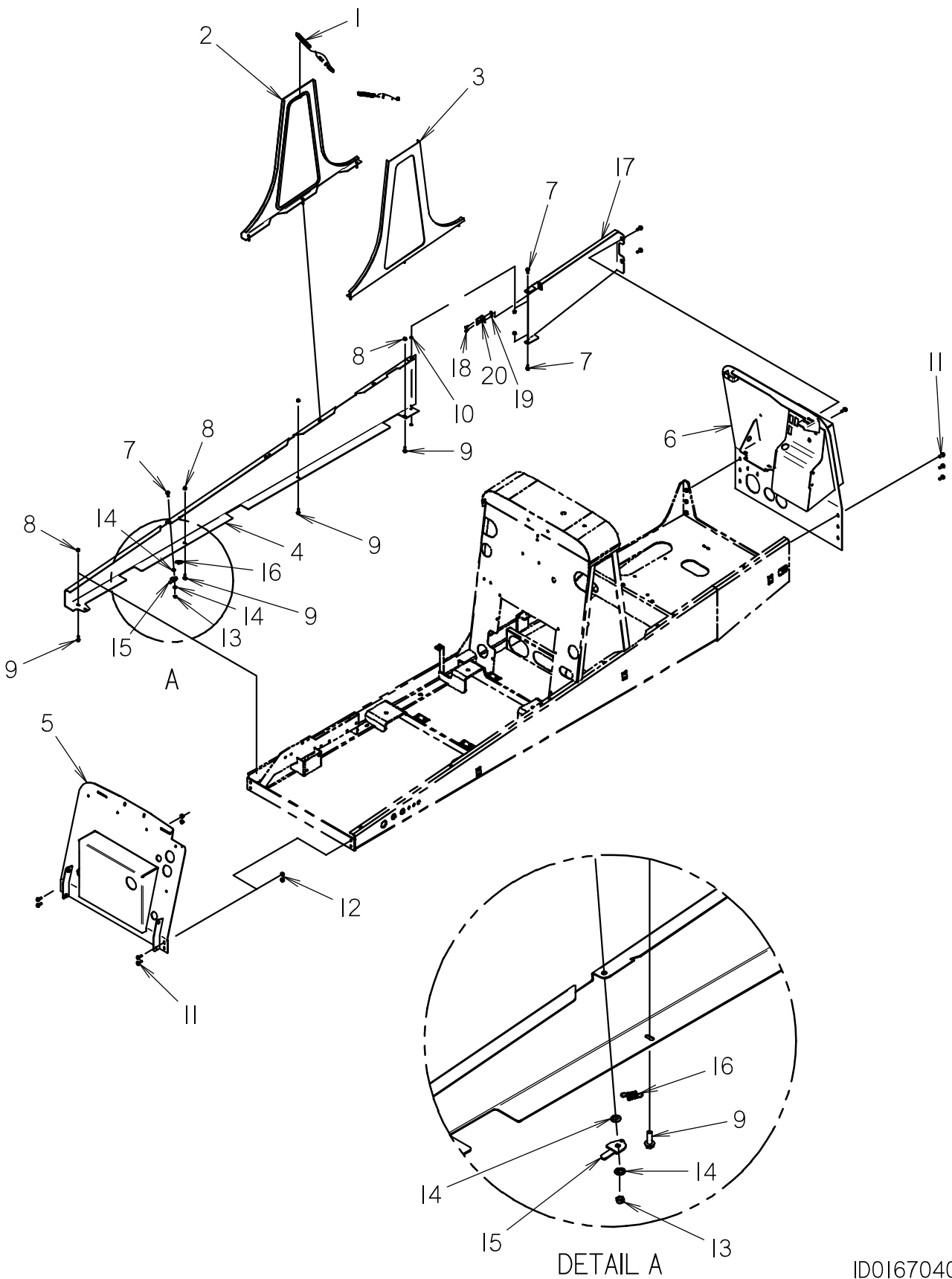

ENGINE SKID COVERS

REF NO.	PART NUMBER	QTY	DESCRIPTION	REMARKS
1	115-605	2	EXTENSION SPRING	
2	300-1658	1	ARCH COVER (RIGHT)	
3	300-1664	1	ARCH COVER (LEFT)	
4	300-1214	1	SIDE PLATE	
5	300-6156	1	FRONT MOUNT	
6	329-100	1	REAR PANEL	
7	106-162	3	FLG SCREW (M8-1.25 X 20MM, GD8)	
8	106-386	6	FLG LOCKNUT (M8-1.25)	
9	106-381	4	FLG LK SCREW (M8-1.25 X 25MM)	
10	179-593	2	BUSHING	
11	106-724	10	FLG SCREW (M10-1.50 X 25MM)	
12	106-387	4	FLG LOCKNUT (M10-1.50)	
13	107-096	1	LOCKNUT (M8-1.25, NLK)	
14	105-805	2	WASHER BELLEVILLE (3/8)	
15	300-4642	1	CENTER LATCH BRACKET	
16	115-619	1	EXTENSION SPRING	
17	300-4767	1	SIDE PANEL	
18	107-193	2	SCREW (M6-1.00 X 16MM,BUT SOC)	
19	106-106	2	NUT (M6-1.00)	
20	300-5281	1	MOUNT BRACKET	

NOT SHOWN:

116-724 - BULK SEAL (3/32", SOLD PER FT) VARIOUS LENGTHS USED
 116-259 - BULK SEAL (1/2", SOLD PER FT) VARIOUS LENGTHS USED

FOOTNOTES:

NOTE:

REAR CONTROLS

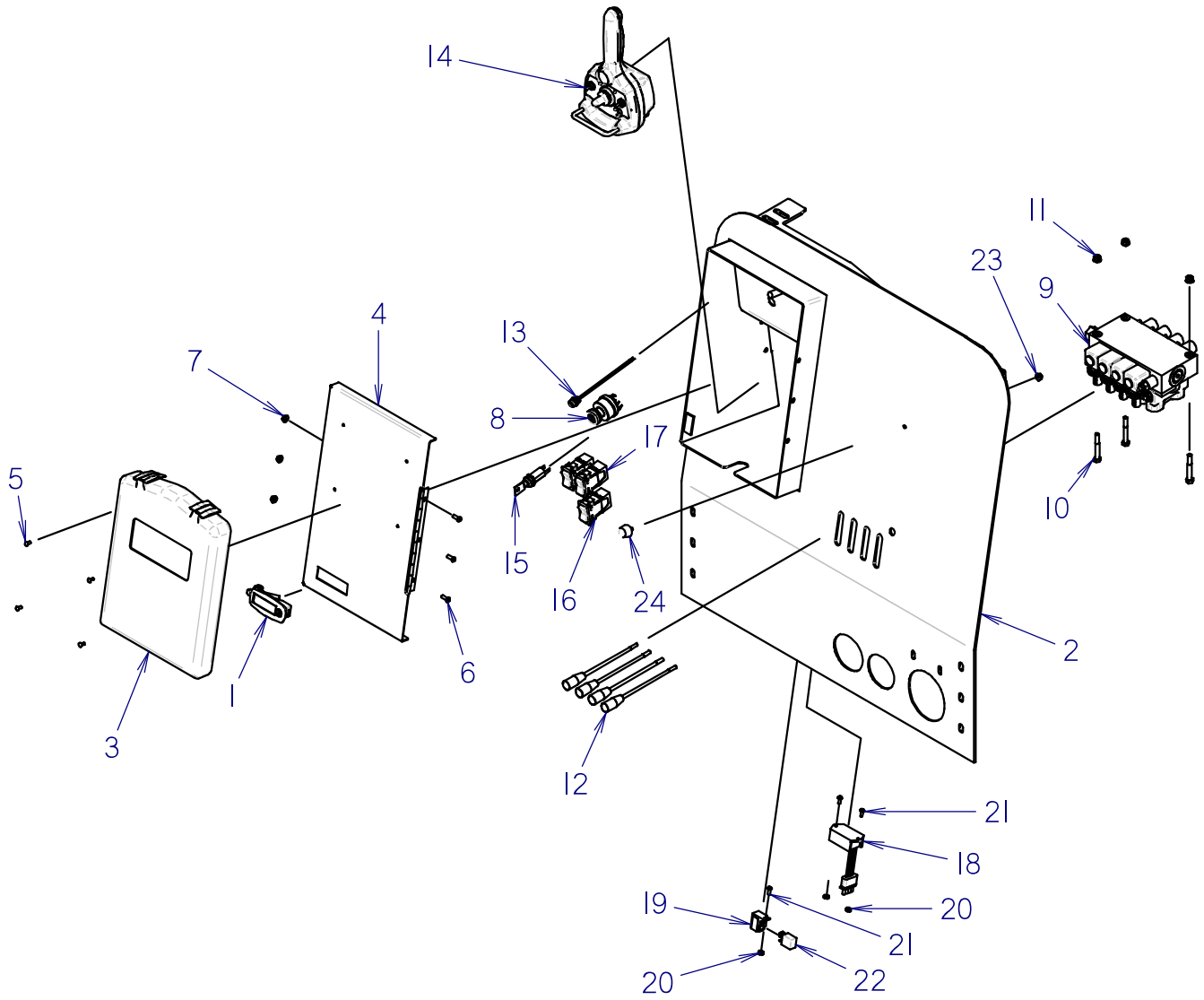

REAR CONTROLS

REF NO.	PART NUMBER	QTY	DESCRIPTION	REMARKS
1	117-558	1	LATCH, ADJUST LEVER (LOCKING)	
2	329-100	1	REAR PANEL	
3	318-588	1	MANUAL COMPARTMENT	
4	300-1573	1	ACCESS DOOR	
5	110-560	4	POP RIVET (3/16" X 1/2", ALUM)	
6	107-193	3	SCREW (M6-1.00 X 16MM,BUT SOC)	
7	106-385	3	FLG LOCKNUT (M6-1.00)	
8	214-852	1	IGNITION SWITCH	
9	150-1415	1	VALVE	
10	106-570	3	SCREW (M8-1.25 X 60MM)	
11	106-386	3	FLG LOCKNUT (M8-1.25)	
12	365-426	4	LEVER (M8-1.25 X 200MM)	
13	214-563	1	RED LED (12V DC)	
14	214-589	1	GROUND DRIVE CONTROL	
15	214-908	1	ON-OFF KEY SWITCH	
16	217-917	1	ROCKER SWITCH (DPDT) OFF-(ON)	
17	214-489	2	ROCKER SW (DPDT) (ON)-OFF-(ON)	
18	217-184	1	DELAY TIMER (2-SECOND)	
19	217-194	1	MICRO RELAY BASE	
20	106-048	3	LOCKNUT (#10-24)	
21	105-185	3	BOLT (#10-24 X 1/2", RD SLT)	
22	217-710	1	MICRO RELAY (SPDT)	
23	105-832	1	FLG LOCKNUT (1/4-NC)	
24	117-533	1	RUBBER BUMPER	

NOT SHOWN:

FOOTNOTES:

NOTE:

ENGINE MOUNTS

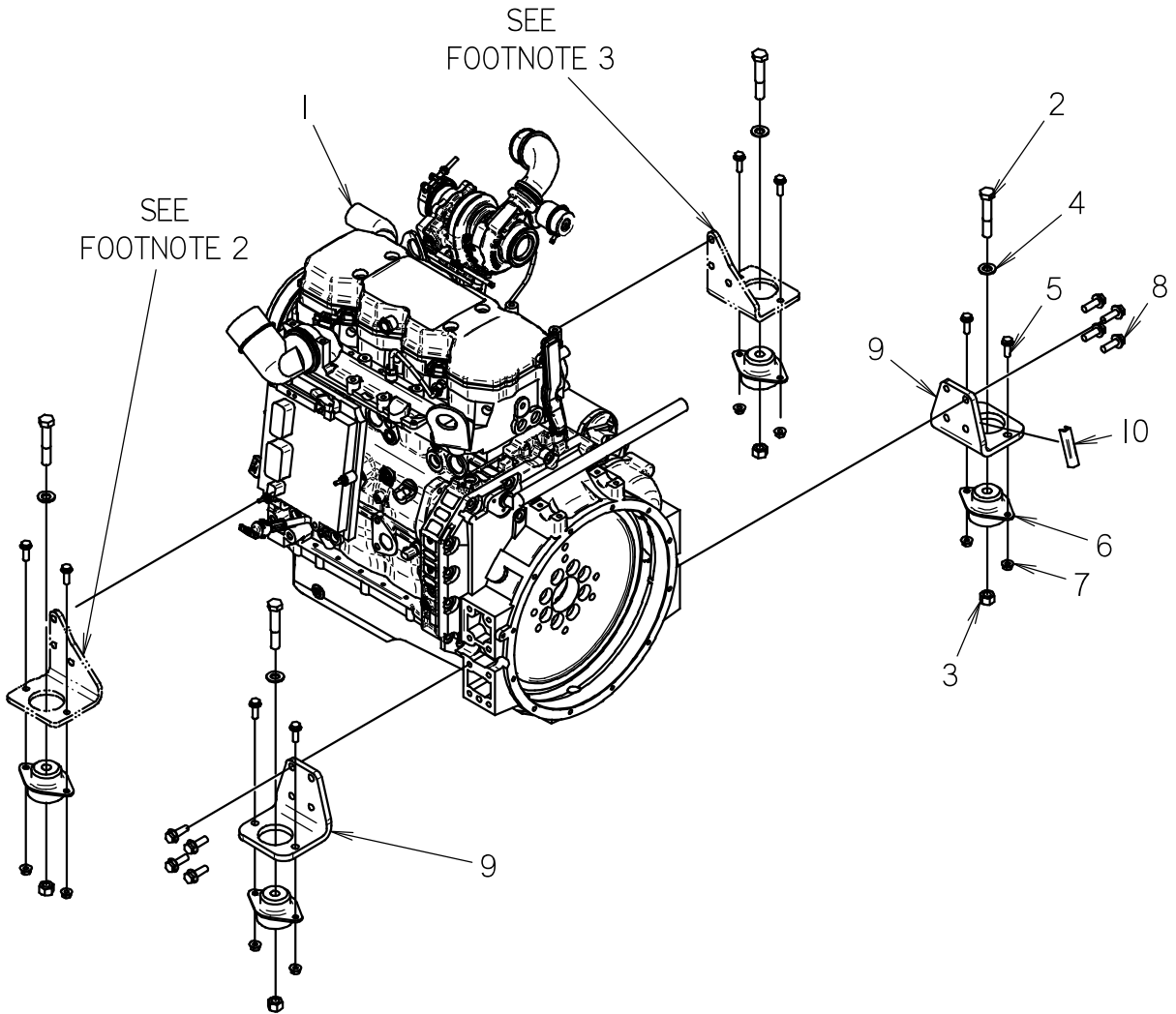

ENGINE MOUNTS

REF NO.	PART NUMBER	QTY	DESCRIPTION	REMARKS
1	194-661	1	ENGINE - CUMMINS QSB4.5	
2	106-342	4	SCREW (M16-2.00 X 90MM)	
3	106-545	4	LOCKNUT (M16-2.0,PRV TRQ,10.9)	
4	106-392	4	WASHER (M16)	
5	106-383	8	FLG LK SCREW (M10-1.50 X 30MM)	
6	116-494	4	SHOCK MOUNT	
7	106-387	8	FLG LOCKNUT (M10-1.50)	
8	106-496	8	FLG SCREW (M12-1.75 X 35MM)	USE LOCTITE 242 - SEE FOOTNOTE 1 FOR TORQUE SPECS.
9	327-798	2	REAR ENGINE MOUNT	
10	116-259	4	BULK EDGE (1/2", SOLD PER FT)	USE 1 @ 10"

NOT SHOWN:

FOOTNOTES:

1. FRONT MOUNTS: TORQUE TO 80 FT-LBS
REAR MOUNTS: TORQUE TO 80 FT-LBS
2. 327-796 FRONT ENGINE MOUNT (LEFT) JT USE ONLY
106-496 3 FLG SCREW (M12-1.75 X 35MM) JT USE ONLY; USE LOCTITE 242 - SEE FOOTNOTE 1 FOR TORQUE SPECS.
300-4114 FRONT ENGINE MOUNT (LEFT) AT USE ONLY
3. 327-797 FRONT ENGINE MOUNT (RIGHT) JT USE ONLY
106-496 3 FLG SCREW (M12-1.75 X 35MM) JT USE ONLY; USE LOCTITE 242 - SEE FOOTNOTE 1 FOR TORQUE SPECS.
300-4113 FRONT ENGINE MOUNT (RIGHT) AT USE ONLY

NOTE:

ELECTRICAL MOUNTING CENTER

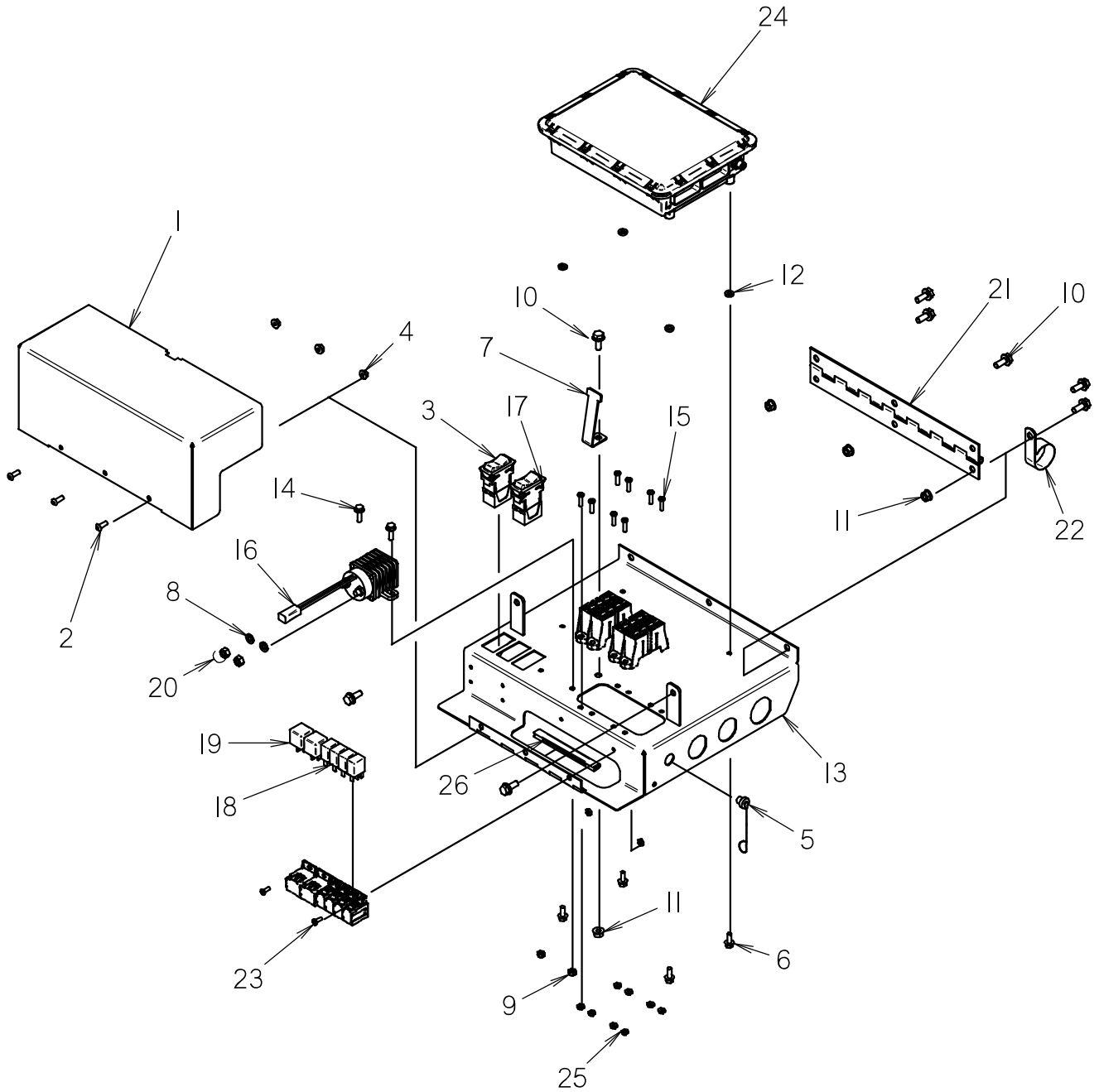

ELECTRICAL MOUNTING CENTER

REF NO.	PART NUMBER	QTY	DESCRIPTION	REMARKS
1	300-2448	1	COVER	
2	107-193	3	SCREW (M6-1.00 X 16MM,BUT SOC)	
3	217-907	1	ROCKER SWITCH (DPDT) ON-ON	
4	106-385	3	FLG LOCKNUT (M6-1.00)	
5	211-078	1	CONNECTOR CAP (TURCK RS-CC)	
6	106-712	4	FLG SCREW (M6-1.00 X 16MM)	
7	118-494	1	LATCH	
8	105-091	2	LOCK WASHER (5/16")	
9	106-237	2	LOCKNUT (M6-1.00,PRV TRQ,NLK)	
10	106-162	8	FLG SCREW (M8-1.25 X 20MM, GD8)	
11	106-386	4	FLG LOCKNUT (M8-1.25)	
12	155-751	4	WASHER (1/4", NEOPRENE)	
13	329-687	1	MOUNTING BRACKET	
14	106-379	2	FLG LK SCREW (M6-1.00 X 20MM)	
15	106-049	8	BOLT (#10-24 X 3/4", PLPS)	
16	215-1086	1	CONTACTOR	
17	214-489	1	ROCKER SW (DPDT) (ON-OFF-(ON))	
18	217-710	4	MICRO RELAY (SPDT)	
19	217-826	2	MINI RELAY (SPDT)	
20	105-213	2	NUT (5/16-NF)	
21	105-1073	1	HINGE	
22	110-332	1	BOLT-ON CLAMP (1-5/8")	
23	105-185	2	BOLT (#10-24 X 1/2", RD SLT)	
24	220-1009	1	JT CONTROLLER W/CAN	
25	106-048	10	LOCKNUT (#10-24)	
26	115-686	8	BULK EDGE (5/32",SOLD PER 1")	USE 1 @ 8"

NOT SHOWN:

211-017	1	12V-5V VOLTAGE CONVERTER	USE ON "AT" ONLY
105-185	4	BOLT (#10-24 x 1/2")	USE WITH 211-017
106-048	4	LOCKNUT (#10-24)	USE WITH 211-017
217-912	1	ROCKER SWITCH (DPDT) ON-ON-ON	USE ON "AT" ONLY, USE MIDDLE SWITCH CUTOUT
110-962	1	FILLER PLUG	USE ON "JT" ONLY, USE MIDDLE SWITCH CUTOUT

FOOTNOTES:
NOTE:

ESID/TETHER MODULE MOUNTING

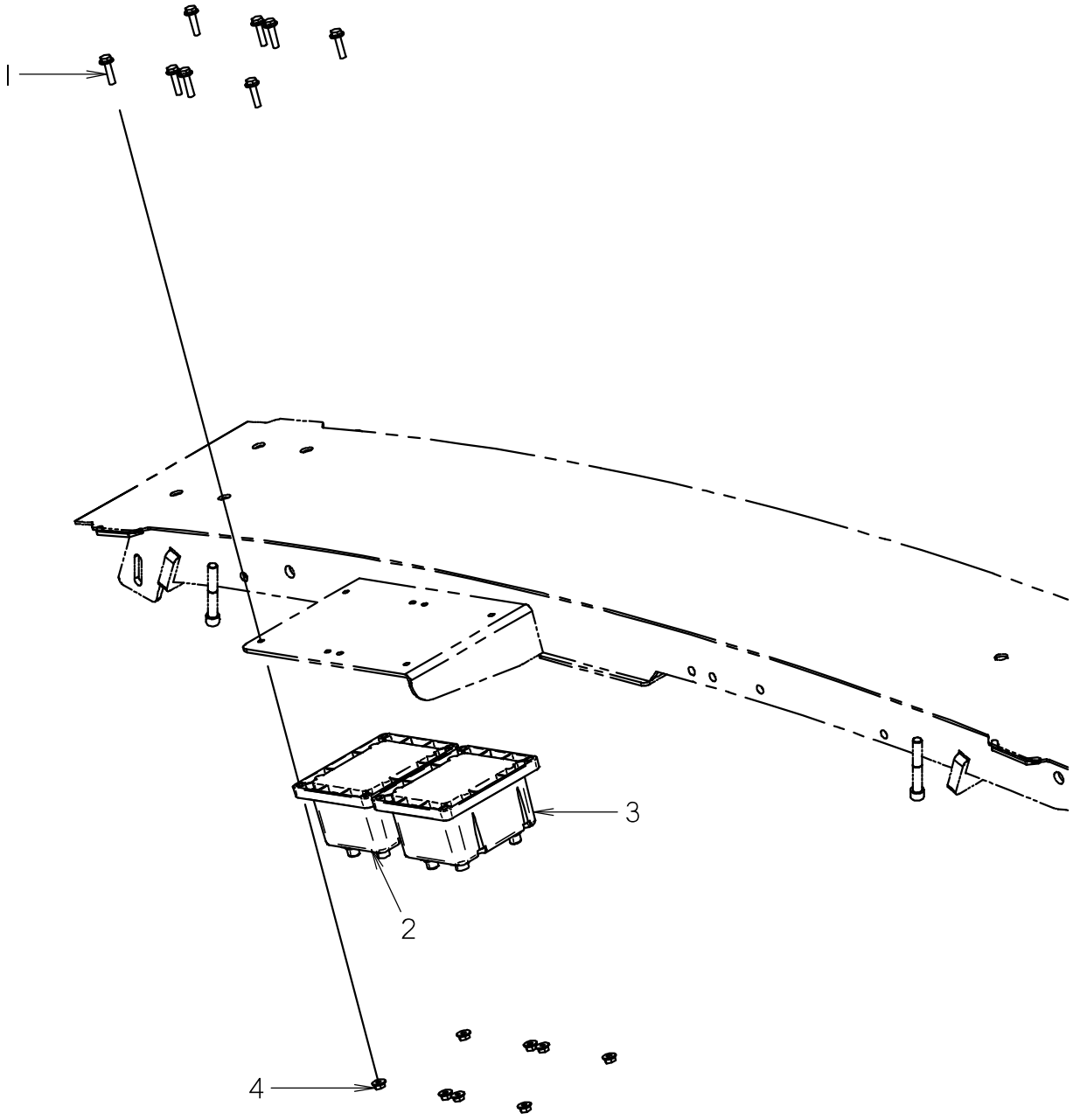

ESID/TETHER MODULE MOUNTING

REF NO.	PART NUMBER	QTY	DESCRIPTION	REMARKS
1	106-848	8	FLG SCREW (M6-1.00 X 25MM)	
2	220-1028	1	TETHER MODULE W/CAN	
3	220-1027	1	ESID MODULE W/CAN	
4	106-385	8	FLG LOCKNUT (M6-1.00)	
5	327-174	1	FRONT HOOD SUPPORT	

NOT SHOWN:

FOOTNOTES:

NOTE:

ENGINE DIAGNOSTIC PORT

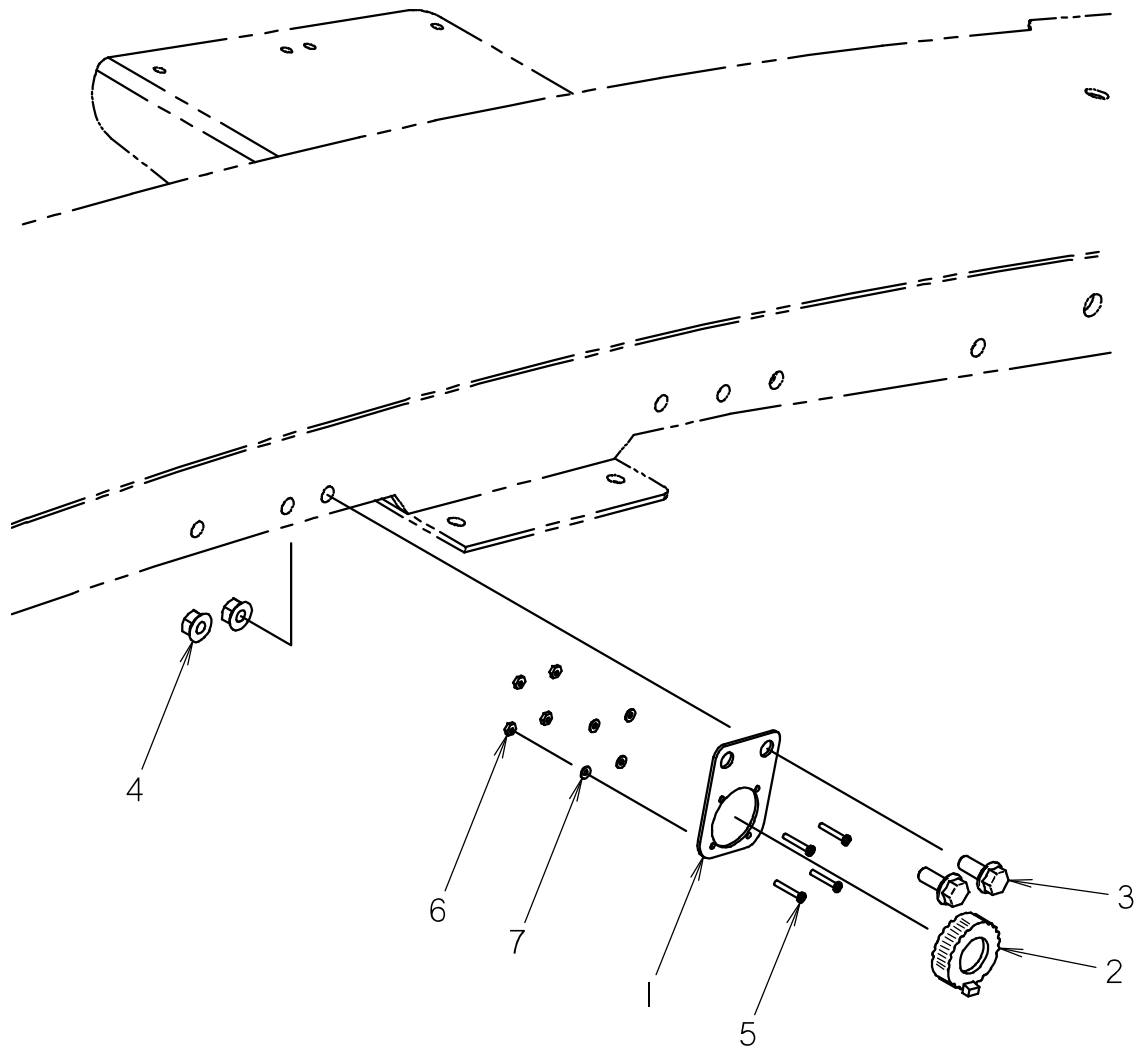

ENGINE DIAGNOSTIC PORT

REF NO.	PART NUMBER	QTY	DESCRIPTION	REMARKS
1	300-4027	1	BRACKET	
2	213-035	1	DUST CAP W/ LANYARD	
3	106-162	2	FLG SCREW (M8-1.25 X 20MM, GD8)	
4	106-386	2	FLG LOCKNUT (M8-1.25)	
5	107-269	4	SCREW (#4-40 X 3/4", PAN)	
6	106-277	4	NUT, (#4-40 BRASS)	
7	106-279	4	WASHER, FLAT, #4, BRS	

NOT SHOWN:

FOOTNOTES:

NOTE:

ENGINE GRID HEATER

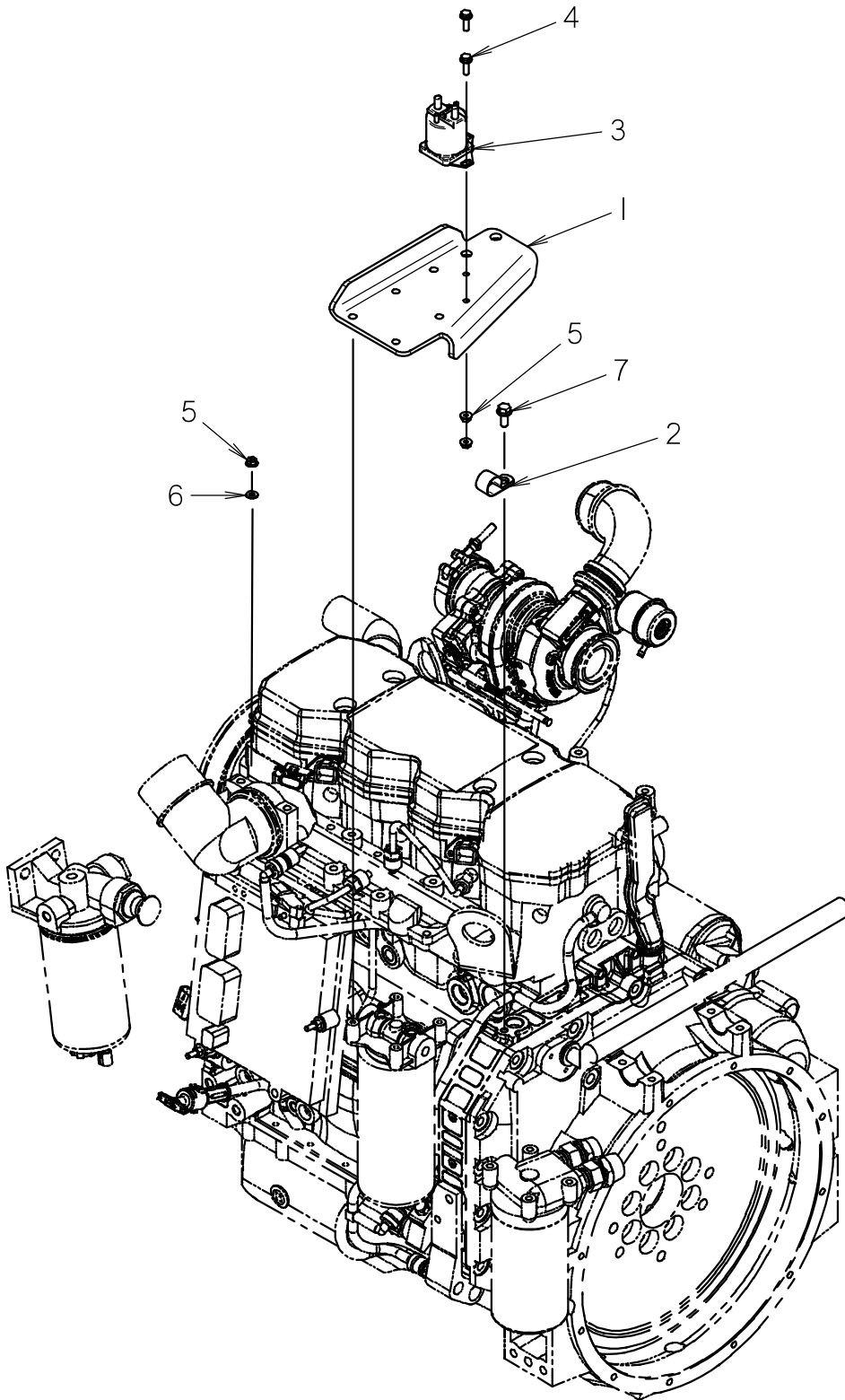

ENGINE GRID HEATER

REF NO.	PART NUMBER	QTY	DESCRIPTION	REMARKS
1	300-1554	1	BRACKET	
2	110-333	1	BOLT-ON CLAMP (1")	
3	214-979	1	PREHEATER SOLENOID (12V)	
4	106-379	2	FLG LK SCREW (M6-1.00 X 20MM)	
5	106-385	3	FLG LOCKNUT (M6-1.00)	
6	105-284	1	WASHER (3/16")	
7	106-162	1	FLG SCREW (M8-1.25 X 20MM, GD8)	

NOT SHOWN:

215-1221	1	GRID HEATER RELAY CABLE	TO PREHEATER SOLENOID TO HEATER FUSE
215-1222	1	GRID HEATER CABLE	TO PREHEATER SOLENOID TO GRID HEATER

FOOTNOTES:

NOTE:

BATTERY
ENDS WITH S/N:

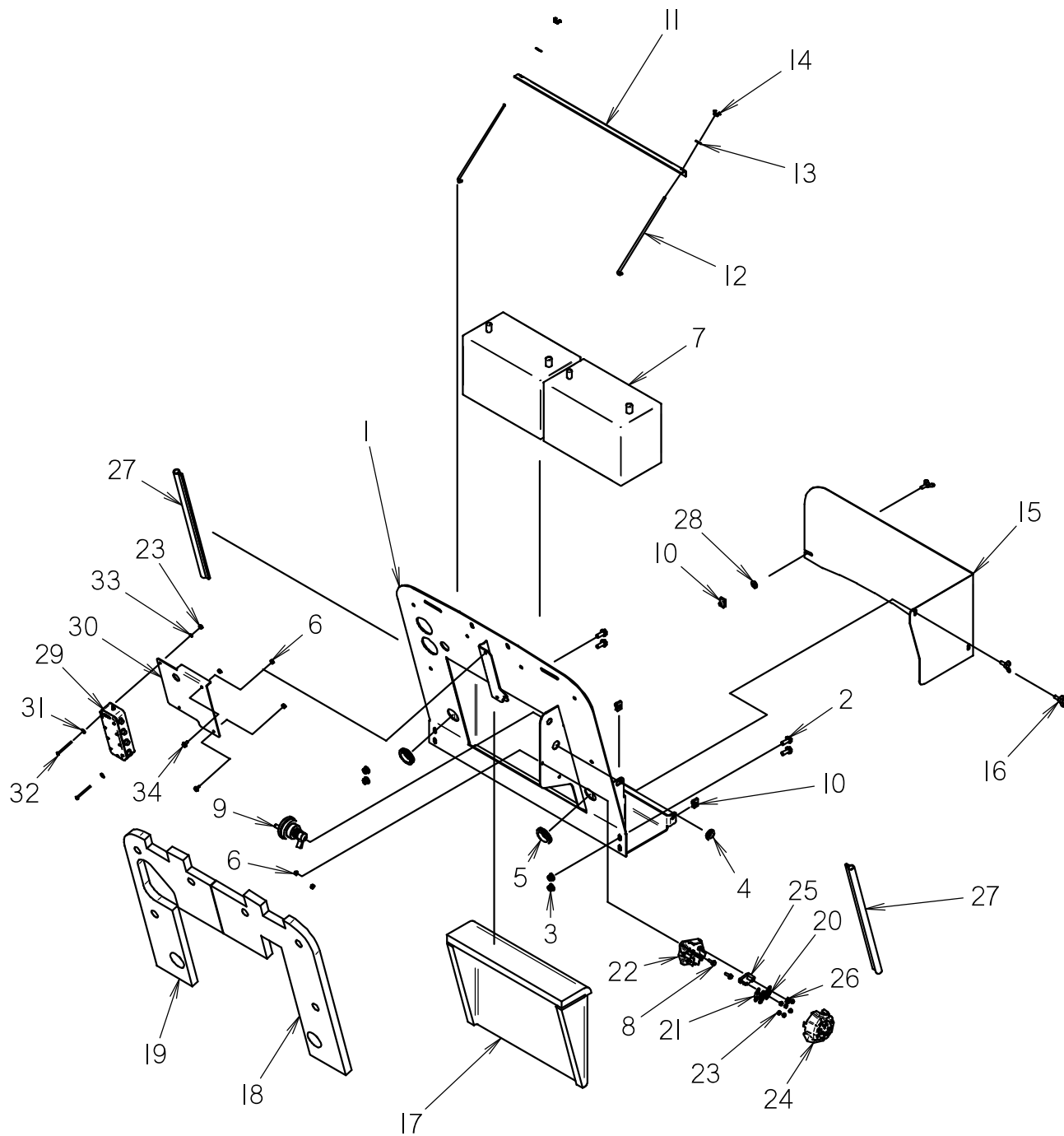

BATTERY ENDS WITH S/N:

REF NO.	PART NUMBER	QTY	DESCRIPTION	REMARKS
1	329-635	1	FRONT MOUNT	
2	106-724	4	FLG SCREW (M10-1.50 X 25MM)	
3	106-387	4	FLG LOCKNUT (M10-1.50)	
4	115-069	1	GROMMET (3/4")	
5	115-320	2	GROMMET (1-1/2")	
6	106-106	4	NUT (M6-1.00)	
7	215-262	2	BATTERY (12V, 925 AMP)	
8	106-161	2	FLG SCREW (M6-1.00 X 20MM)	
9	217-819	1	BATTERY DISCONNECT SWITCH	
10	106-551	3	CLIP NUT (M8-1.25)	
11	108-239	1	BATTERY HOLD-DOWN	
12	337-001	2	BATTERY BOLT	
13	105-095	2	WASHER (1/4")	
14	195-339	2	WING NUT (1/4-NC)	
15	329-596	1	COVER	
16	106-795	3	WING SCREW (M8-1.25 X 20MM)	
17	362-1000	1	SOUND INSULATION	
18	362-1035	1	SOUND INSULATION	
19	362-1001	1	SOUND INSULATION	
20	211-305	2	BK/AMI 125 AMP FUSE	
21	211-311	1	BK/AMI 100 AMP FUSE	
22	215-1009	1	MAIN FUSE HOLDER BASE	
23	106-048	8	LOCKNUT (#10-24)	
24	215-1010	1	MAIN FUSE HOLDER COVER	
25	215-1011	1	BUSSBAR (MAIN FUSE HOLDER)	
26	105-047	1	LOCKNUT (3/8-NC)	
27	116-421	68	BULK EDGE (1/8", SOLD PER FT)	2 @ 34"
28	105-117	1	WASHER (5/16")	
29	215-1354	1	J-BOX	SEE FOOTNOTES 1 & 2
30	300-6967	1	J-BOX MOUNT	SEE FOOTNOTE 1
31	105-284	2	WASHER (3/16")	SEE FOOTNOTE 1
32	106-014	2	BOLT (#10-24 X 1/2", RD SLT)	SEE FOOTNOTE 1
33	106-056	1	EXT STAR WASHER (#10)	SEE FOOTNOTE 1
34	106-378	2	FLG LK SCREW (M6-1.00 X 12MM)	SEE FOOTNOTES 1 & 3

NOT SHOWN:

FOOTNOTES:

- BEGINS WITH S/N: "JT" CMWJ30MIL80000044, "AT" CMWJ30ATV80000032
- 213-359 CAN WITCH/JI939 J-BOX; ENDS WITH S/N: "JT" CMWJ30MIA80000043, "AT" CMWJ30ATV80000029
- 107-025 SCREW (M6-1.00 X 50MM); ENDS WITH S/N: "JT" CMWJ30MIA80000043, "AT" CMWJ30ATV80000029

NOTE:

BATTERY

BEGINS WITH S/N: CMWJ30M1E80000239

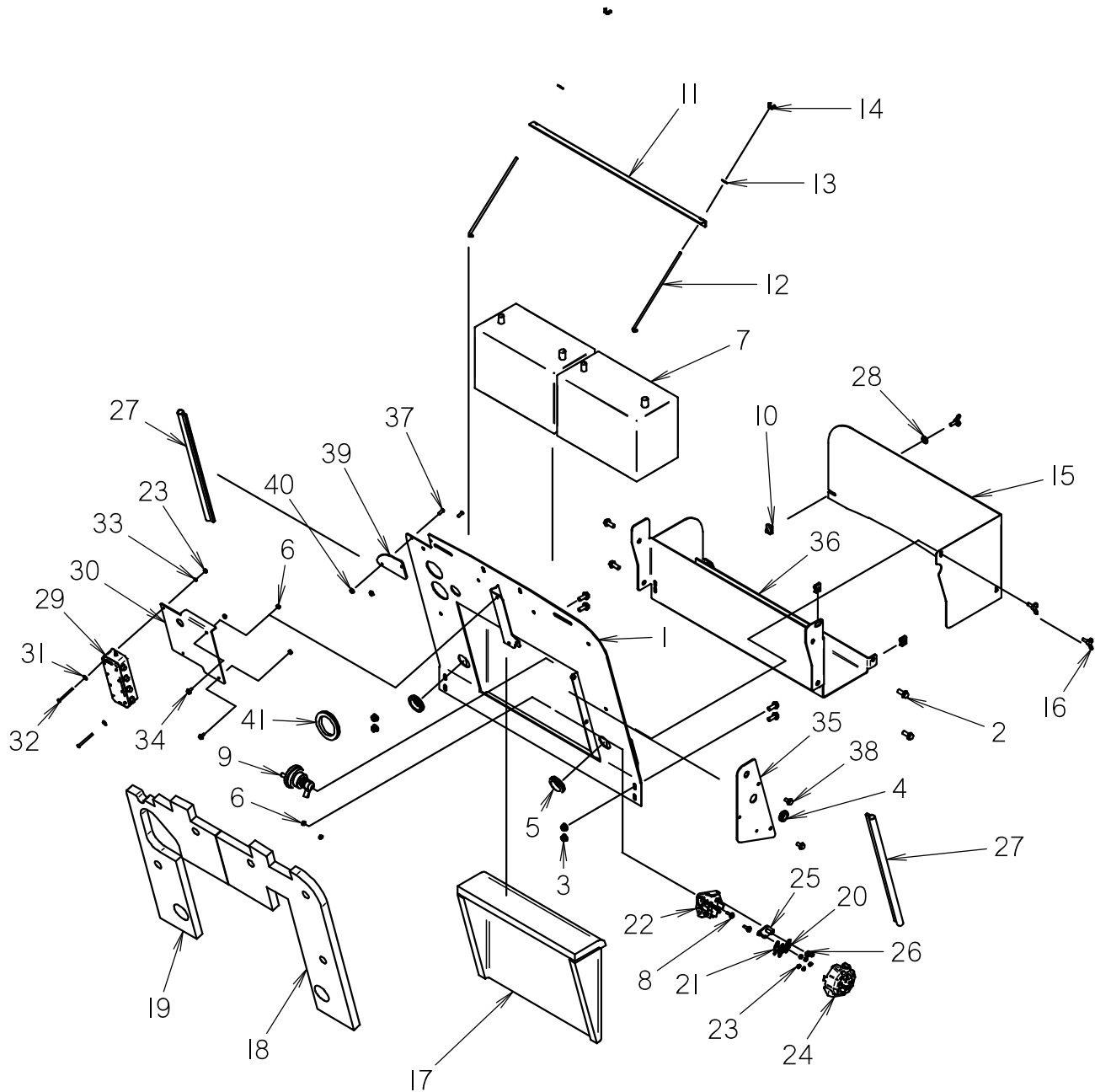

BATTERY

BEGINS WITH S/N: CMWJ30M1E80000239

REF NO.	PART NUMBER	QTY	DESCRIPTION	REMARKS
1	300-6156	1	FRONT MOUNT	
2	106-724	8	FLG SCREW (M10-1.50 X 25MM)	
3	106-387	4	FLG LOCKNUT (M10-1.50)	
4	115-069	1	GROMMET (3/4")	
5	115-320	2	GROMMET (1-1/2")	
6	106-106	4	NUT (M6-1.00)	
7	215-262	2	BATTERY (12V, 925 AMP)	
8	106-161	2	FLG SCREW (M6-1.00 X 20MM)	
9	217-819	1	BATTERY DISCONNECT SWITCH	
10	106-551	3	CLIP NUT (M8-1.25)	
11	108-239	1	BATTERY HOLD-DOWN	
12	337-001	2	BATTERY BOLT	
13	105-095	2	WASHER (1/4")	
14	195-339	2	WING NUT (1/4-NC)	
15	329-596	1	COVER	
16	106-795	3	WING SCREW (M8-1.25 X 20MM)	
17	362-1000	1	SOUND INSULATION	
18	362-1035	1	SOUND INSULATION	
19	362-1001	1	SOUND INSULATION	
20	211-305	2	BK/AM 125 AMP FUSE	
21	211-311	1	BK/AM 100 AMP FUSE	
22	215-1009	1	MAIN FUSE HOLDER BASE	
23	106-048	8	LOCKNUT (#10-24)	
24	215-1010	1	MAIN FUSE HOLDER COVER	
25	215-1011	1	BUSSBAR (MAIN FUSE HOLDER)	
26	105-047	1	LOCKNUT (3/8-NC)	
27	116-421	68	BULK EDGE (1/8", SOLD PER FT)	2 @ 34"
28	105-117	1	WASHER (5/16")	
29	215-1354	1	J-BOX	
30	300-6967	1	J-BOX MOUNT	
31	105-284	2	WASHER (3/16")	
32	106-014	2	BOLT (#10-24 X 2-1/4", RD SLT)	
33	106-056	1	EXT STAR WASHER (#10)	
34	106-378	2	FLG LK SCREW (M6-1.00 X 12MM)	
35	300-6221	1	DISCONNECT MOUNT	
36	300-6154	1	BATTERY TRAY	
37	107-193	2	SCREW (M6-1.00 X 16MM,BUT SOC)	
38	107-095	2	FLG SCREW (M8-1.25 X 16MM)	
39	300-6222	1	FILLER PLATE	
40	106-385	2	FLG LOCKNUT (M6-1.00)	
41	105-1050	1	GROMMET (2-1/2")	

NOT SHOWN:

FOOTNOTES:

NOTE:

BATTERY CABLES

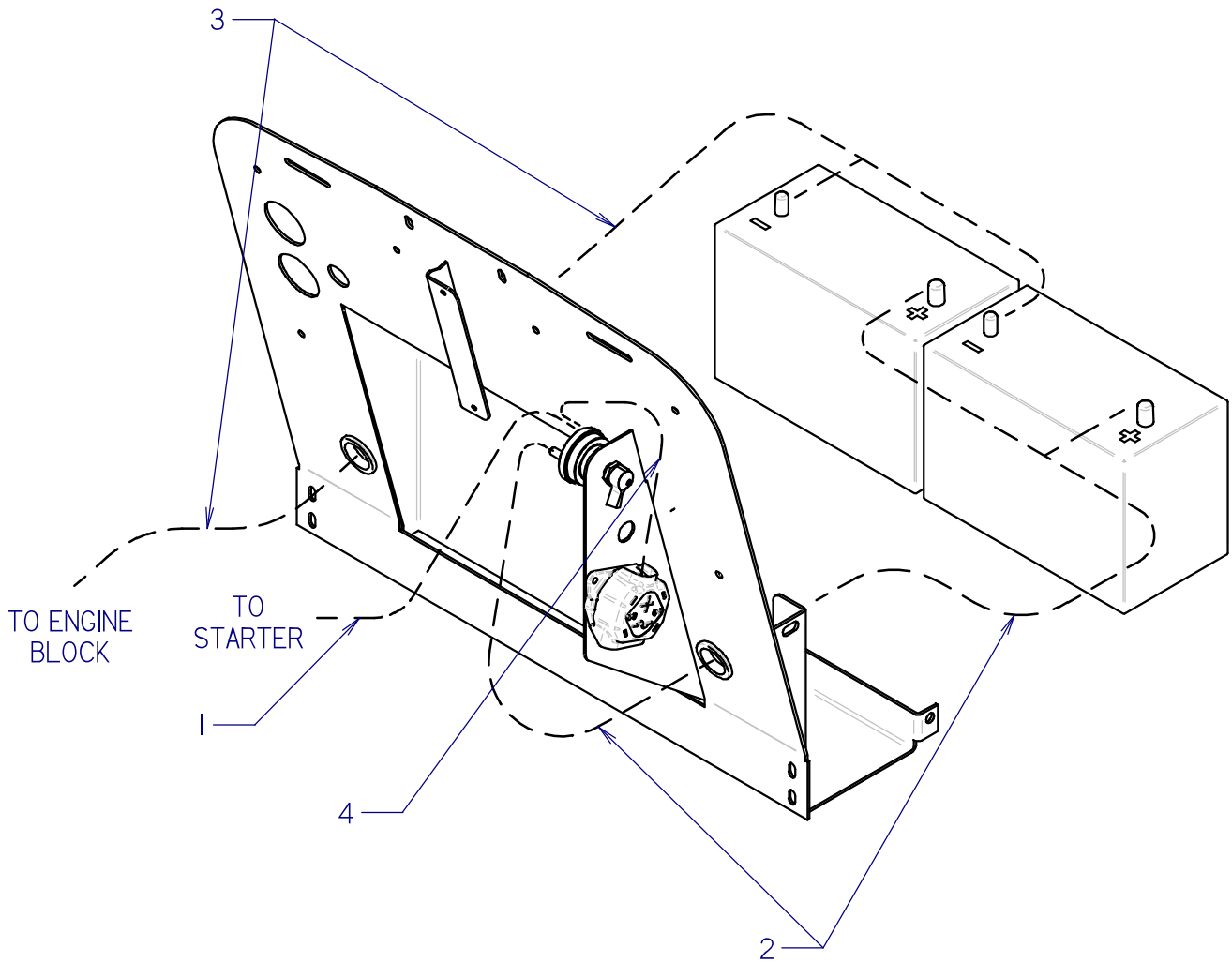

BATTERY CABLES

REF NO.	PART NUMBER	QTY	DESCRIPTION	REMARKS
1.	215-1157	1	BATTERY CABLE	FROM BATTERY DISCONNECT TO STARTER
2.	215-1158	1	BATTERY CABLE	FROM POSITIVE BATTERY TERMINALS TO BATTERY DISCONNECT
3.	215-1159	1	BATTERY CABLE	FROM NEGATIVE BATTERY TERMINALS TO ENGINE BLOCK
4.	215-1160	1	BATTERY CABLE	FROM BATTERY DISCONNECT TO FUSE BLOCK

NOT SHOWN:

FOOTNOTES:

NOTE:

FUEL SYSTEM

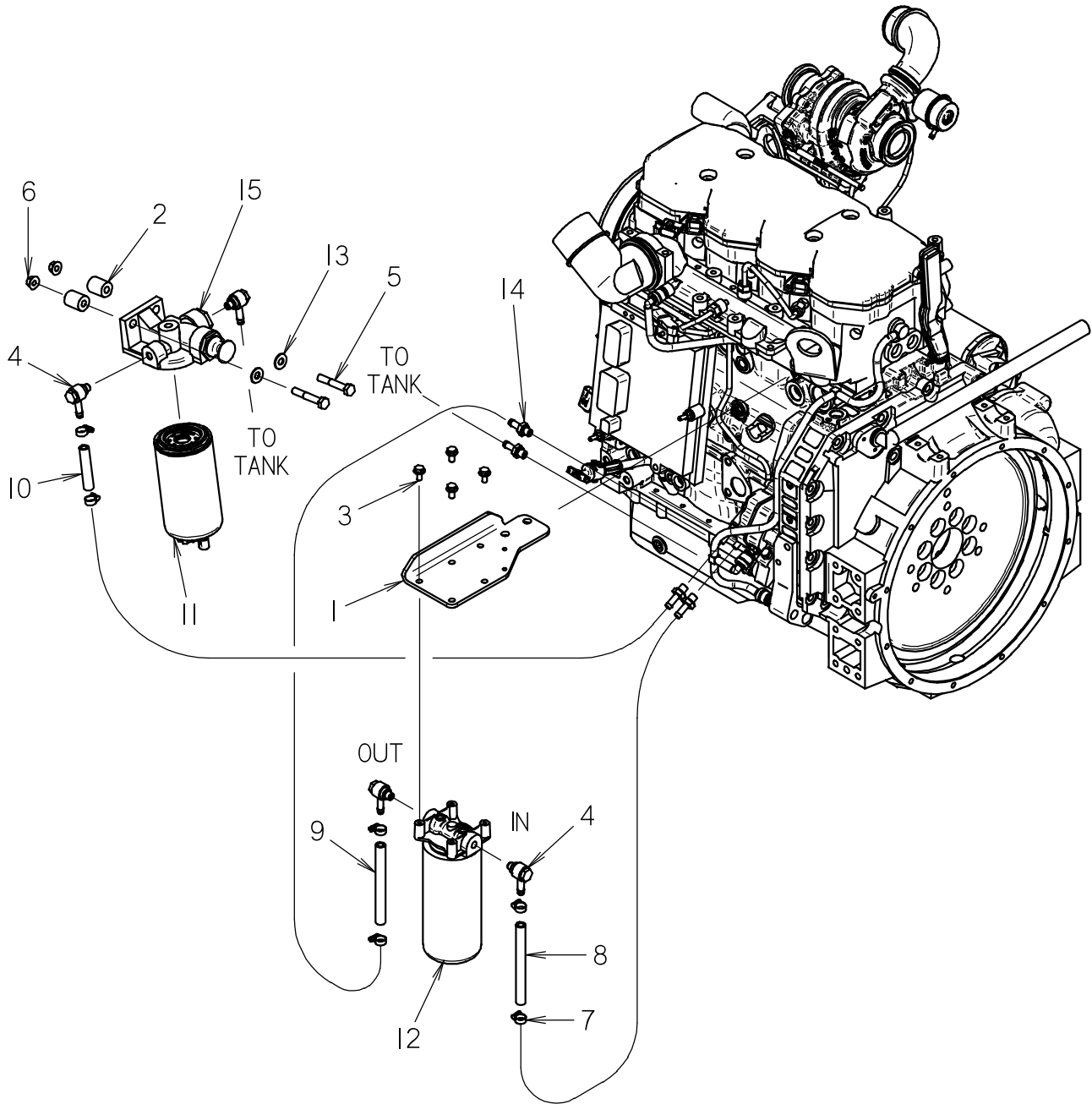

FUEL SYSTEM

REF NO.	PART NUMBER	QTY	DESCRIPTION	REMARKS
1	300-1554	1	BRACKET	
2	181-303	2	SPACER	
3	106-380	4	FLG LK SCREW (M8-1.25 X 16MM)	USE LOCTITE 242 OR EQUIVALENT
4	159-977	4	BANJO FITTING (M12-1.5-06H)	SEE FOOTNOTE 1
5	106-142	2	SCREW (M10-1.50 X 65MM)	
6	106-387	2	FLG LOCKNUT (M10-1.50)	
7	110-249	6	WORM CLAMP (1/4" TO 5/8")	
8	105-1142	27	BULK HOSE (3/8", SOLD PER FT)	
9	105-1142	20	BULK HOSE (3/8", SOLD PER FT)	
10	116-881	35	BULK HOSE (3/8", SOLD PER FT)	
11	195-1035	1	FUEL FILTER, 25 MICRON	
12	195-1036	1	SECONDARY FUEL FILTER	
13	105-118	2	WASHER (3/8")	
14	150-1824	4	S/O COUPLER (M12-1.50-06H)	
15	500-1411	1	FUEL FILTER HEAD	

NOT SHOWN:

FOOTNOTES:

1. 107-1003 REPLACEMENT SEAL WASHER.

NOTE:

NOTES:

FRAME COMPONENTS

ASSISTED MAKEUP

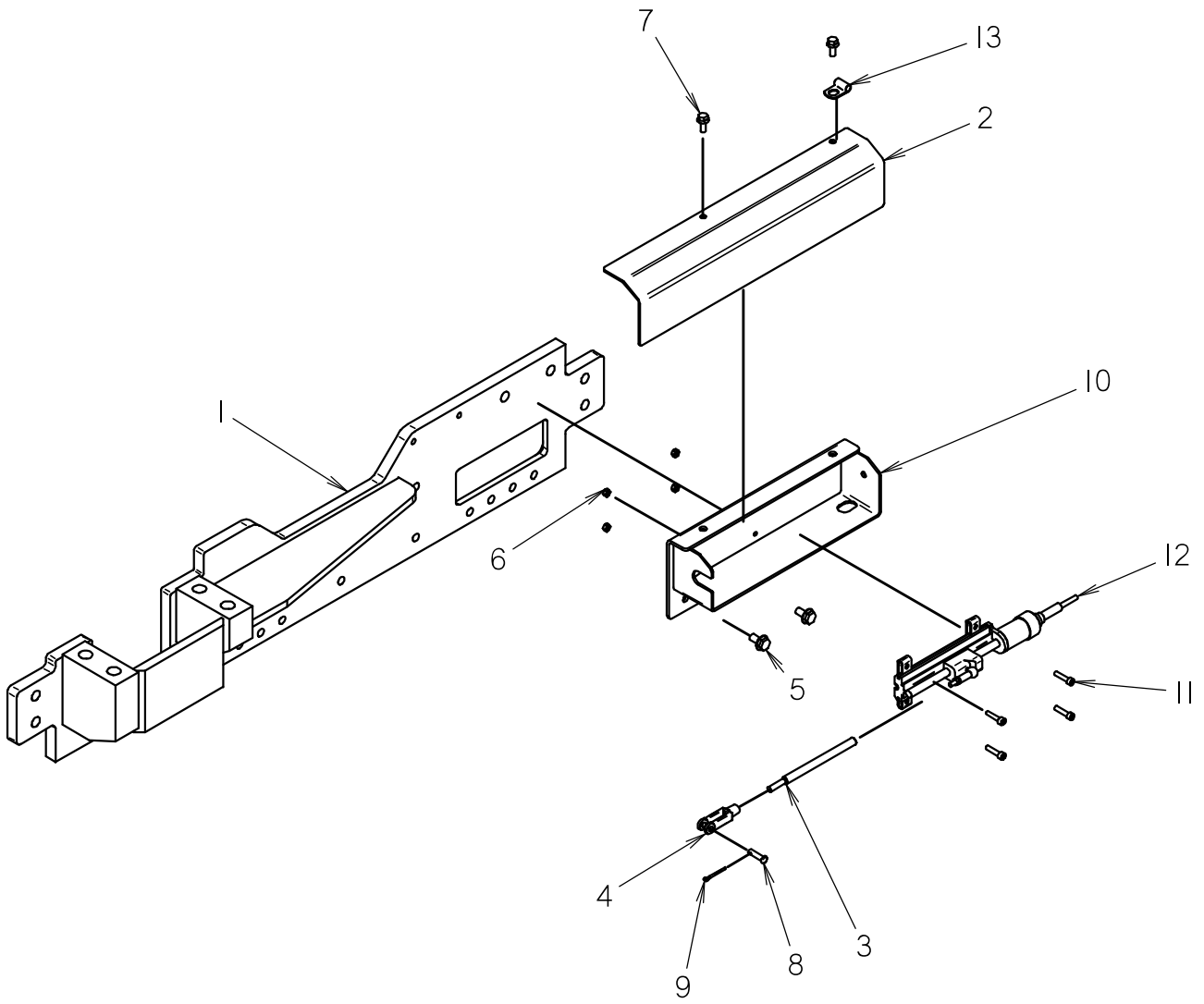

ASSISTED MAKEUP

REF NO.	PART NUMBER	QTY	DESCRIPTION	REMARKS
1	300-2665	1	LEFT SIDE DRIVE PLATE	
2	300-1115	1	COVER	
3	300-1114	1	SENSOR ROD	
4	110-067	1	CLEVIS (1/4-NF)	
5	106-380	2	FLG LK SCREW (M8-1.25 X 16MM)	
6	106-850	4	LOCKNUT (M5-0.80)	
7	106-712	2	FLG SCREW (M6-1.00 X 16MM)	
8	110-082	1	CLEVIS PIN (1/4 X 11/16)	
9	105-508	1	COTTER PIN (3/32" X 1")	
10	300-1118	1	SENSOR MOUNT	
11	106-427	4	SCREW (M5-0.80 X 22MM, SOC)	
12	215-1002	1	POSITION SENSOR	SEE FOOTNOTE 1
13	110-754	1	CLAMP (5/16")	

NOT SHOWN:

FOOTNOTES:

1. 215-1617 MAGNETIC SLIDER. APPLY LOCTITE 242 OR EQUIVALENT TO JAM NUT ON SENSOR BODY

NOTE:

CARRIAGE

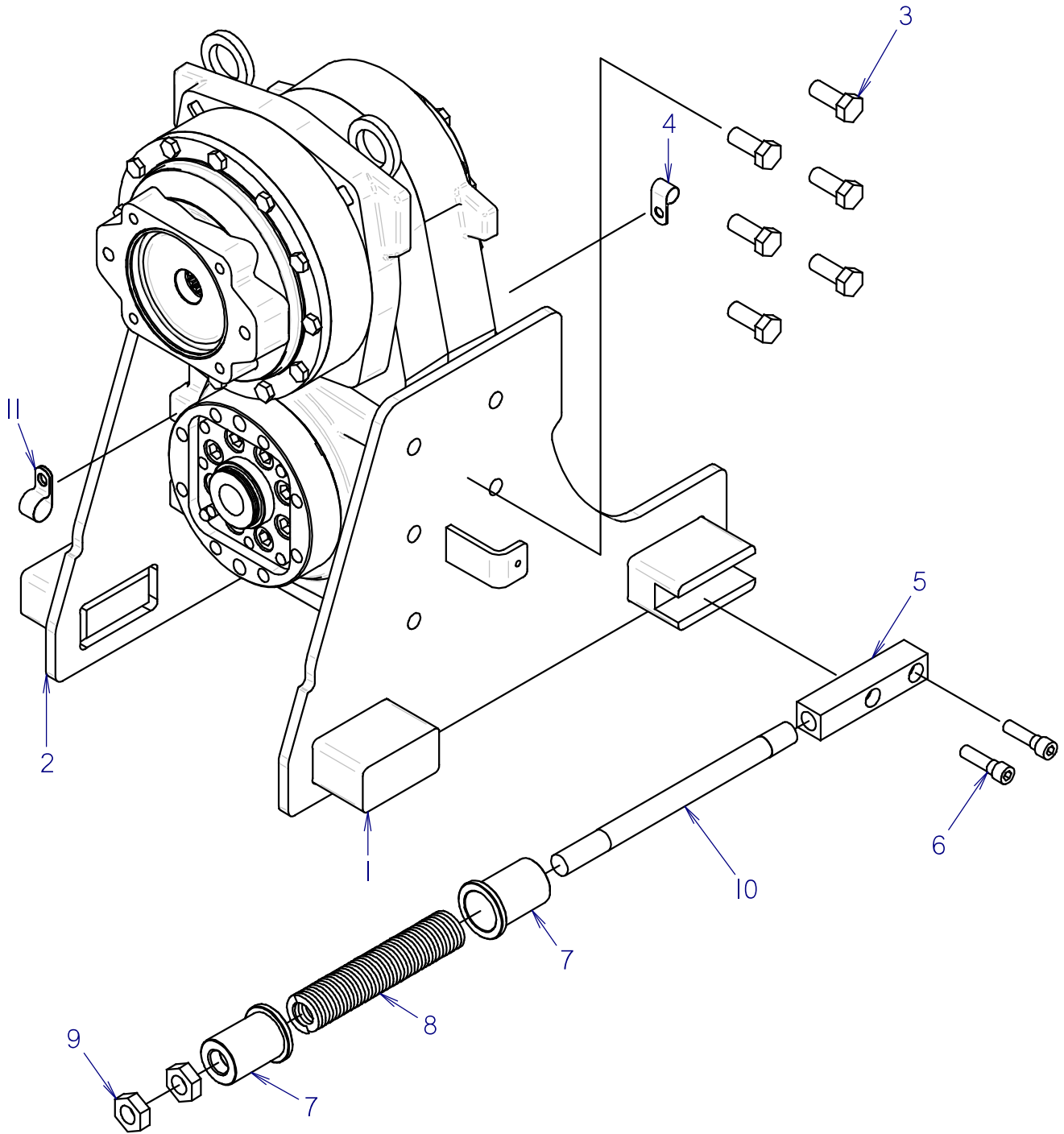

CARRIAGE

REF NO.	PART NUMBER	QTY	DESCRIPTION	REMARKS
1	300-2663	1	LEFT SIDE PLATE	
2	300-2664	1	RIGHT SIDE PLATE	
3	106-478	6	SCREW (M16-2.00 X 40MM, 10.9)	USE LOCTITE 242, TORQUE TO 200 FT-LBS
4	110-259	1	BOLT-ON CLAMP (.625")	
5	300-4789	1	MOUNT BLOCK	
6	106-707	2	SCREW (M12-1.75 X 45MM, SOC)	USE LOCTITE 242, TORQUE TO 95 FT-LBS
7	300-4792	2	SPRING CAP	
8	105-1171	1	COMPRESSION SPRING	
9	107-655	2	JAM NUT (7/8-NC)	
10	300-4790	1	BAR	
11	110-333	1	BOLT-ON CLAMP (1")	

NOT SHOWN:

FOOTNOTES:

NOTE:

REF #3 QTY IS PER SIDE.

REF #4 THRU #9 QTY'S ARE PER ASSEMBLY, 2 ASSEMBLIES PER SIDE

CARRIAGE STOPS

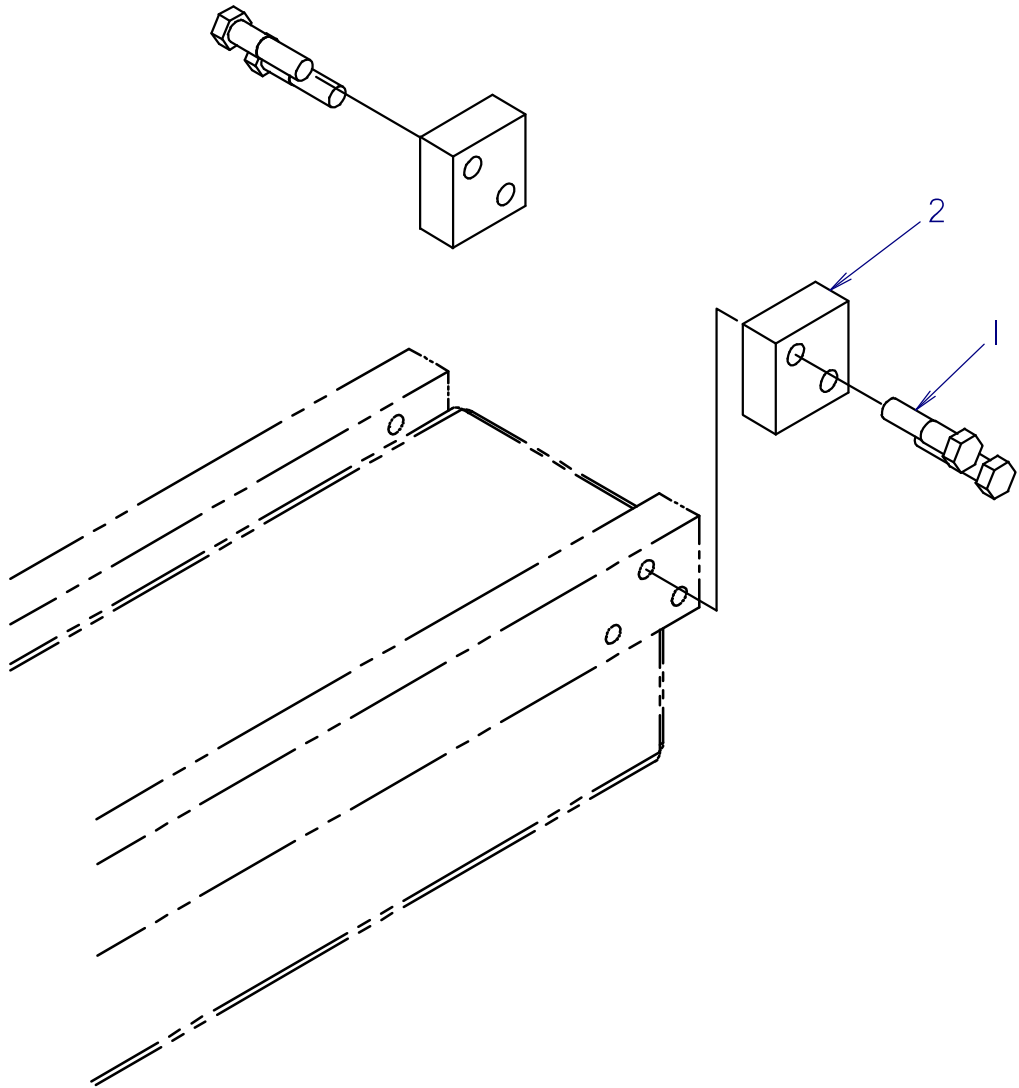

CARRIAGE STOPS

REF NO.	PART NUMBER	QTY	DESCRIPTION	REMARKS
1	I06-666	4	SCREW (M16-2.00 X 65MM, 10.9)	
2	300-I775	2	STOP BLOCK	

NOT SHOWN:

FOOTNOTES:

NOTE:

SPINDLE DRIVE ASSEMBLY "JT"
ENDS WITH S/N: CMWJ30M1A70000011
BEGINS WITH S/N: CMWJ30M1C80000064

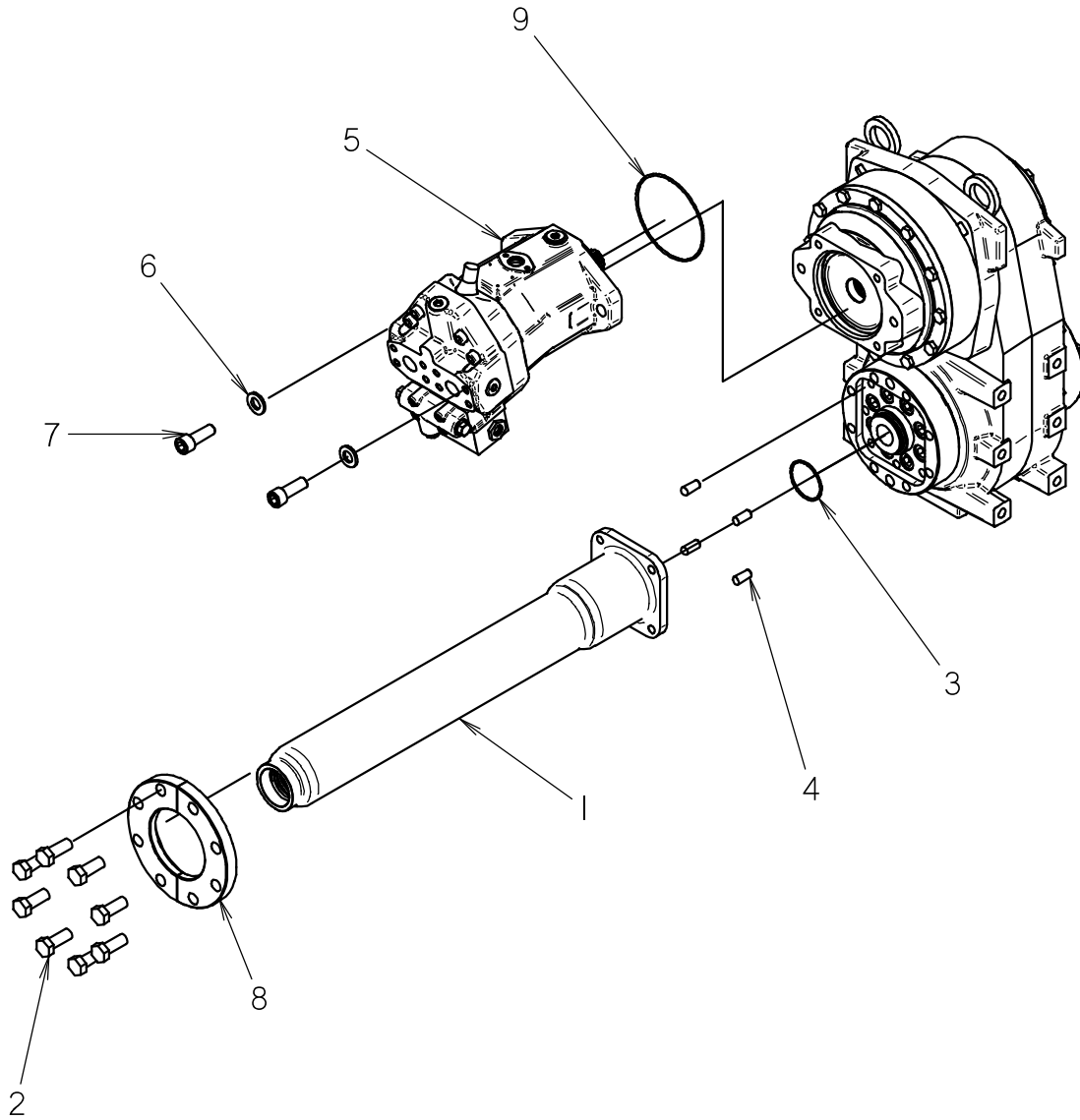

SPINDLE DRIVE ASSEMBLY "JT"

ENDS WITH S/N: CMWJ30M1A70000011

BEGINS WITH S/N: CMWJ30M1C80000064

REF NO.	PART NUMBER	QTY	DESCRIPTION	REMARKS
1	400-1223	1	SAVER SUB 2.II-4F DS	
2	106-478	8	SCREW (M16-2.00 X 40MM, I0.9)	USE 242 LOCTITE OR EQUIVALENT; TORQUE TO 200 FT-LBS
3	157-019	1	O-RING (I39 D90)	
4	107-050	4	PRECISION DOWEL PIN (M12 X 30)	
5	150-1437	1	HYDRAULIC MOTOR	SEE FOOTNOTE I FOR SERVICE PARTS
6	106-398	2	WASHER (M16, HARDENED)	
7	105-997	2	BOLT (5/8-NC X 1-3/4", SOC)	USE 242 LOCTITE OR EQUIVALENT TORQUE TO 200 FT-LBS
8	400-1052	2	LOCK COLLAR	
9	157-084	1	O-RING (I59 D70)	

NOT SHOWN:

214-048 4 PACKARD WP TERMINAL FEMALE
 157-645 4 WEATHER-PAC SEAL (2.80MM)
 215-227 1 4-WAY FEMALE W.P. CONNECTOR

FOOTNOTES:

I. 502-172 SPEED SENSOR
 500-1426 SHAFT SEL RING

NOTE:

SPINDLE DRIVE ASSEMBLY "JT"
BEGINS WITH S/N: CMWJ30M1L70000012
ENDS WITH S/N: CMWJ30M1C80000063

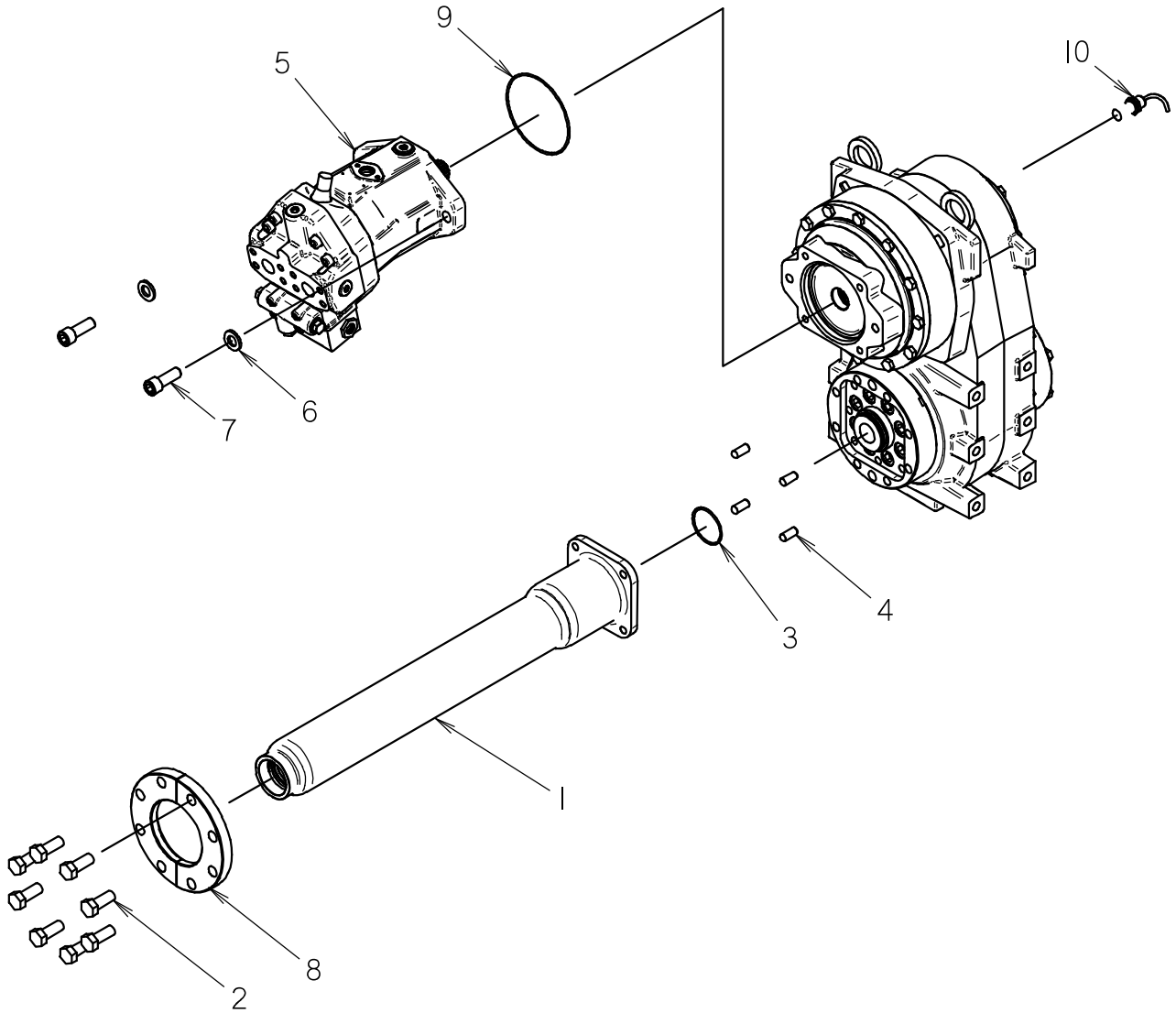

SPINDLE DRIVE ASSEMBLY "JT"

BEGINS WITH S/N: CMWJ30M1L70000012

ENDS WITH S/N: CMWJ30M1C80000063

REF NO.	PART NUMBER	QTY	DESCRIPTION	REMARKS
1	400-1223	1	SAVER SUB 2.II-4F DS	
2	106-478	8	SCREW (M16-2.00 X 40MM, I0.9)	USE 242 LOCTITE OR EQUIVALENT; TORQUE TO 200 FT-LBS
3	157-019	1	O-RING (I39 D90)	
4	107-050	4	PRECISION DOWEL PIN (M12 X 30)	
5	150-1992	1	HYDRAULIC MOTOR	SEE FOOTNOTE 1 FOR SERVICE PARTS
6	106-398	2	WASHER (M16, HARDENED)	
7	105-997	2	BOLT (5/8-NC X 1-3/4", SOC)	USE 242 LOCTITE OR EQUIVALENT TORQUE TO 175 FT-LBS
8	400-1052	2	LOCK COLLAR	
9	157-084	1	O-RING (I59 D70)	
10	215-1004	1	SPEED PICKUP	

NOT SHOWN:

FOOTNOTES:

- I. 500-1426 SHAFT SEAL RING

NOTE:

SPINDLE DRIVE ASSEMBLY "AT"

ENDS WITH S/N: CMWJ30ATE70000021

BEGINS WITH S/N: CMWJ30ATJ80000044

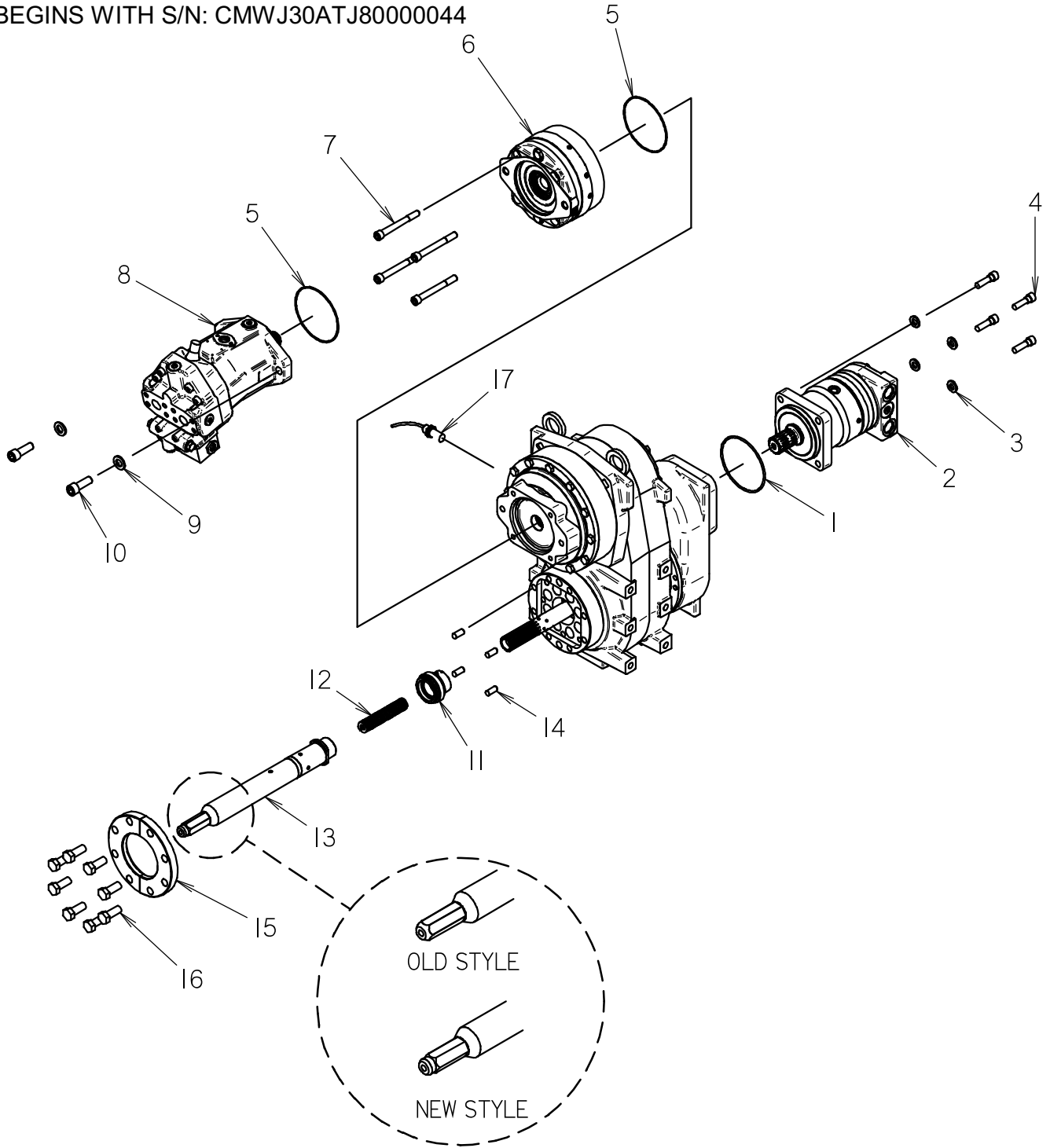

SPINDLE DRIVE ASSEMBLY "AT"
ENDS WITH S/N: CMWJ30ATE70000021
BEGINS WITH S/N: CMWJ30ATJ80000044

REF NO.	PART NUMBER	QTY	DESCRIPTION	REMARKS
1	155-770	1	O-RING (250 D70)	
2	158-208	1	HYDRAULIC MOTOR	SEAL KIT 150-1041
3	106-397	4	WASHER (M12, HARDENED)	
4	106-707	4	SCREW (M12-1.75 X 45MM, SOC)	
5	157-084	2	O-RING (159 D70)	
6	160-1099	1	MODULAR BRAKE	
7	107-495	4	BLT (1/2-NC X 4.50", SOC GD 8)	
8	150-1437	1	HYDRAULIC MOTOR	SEE FOOTNOTE 1 & 2
9	106-398	2	WASHER (M16, HARDENED)	
10	105-997	2	BOLT (5/8-NC X 1-3/4", SOC)	
11	157-469	1	WATER SWIVEL SEAL	
12	105-1262	1	SPRING	BEGINS WITH S/N: CMWJ30ATP80000025, SEE FOOTNOTE 3
13	400-1047	1	HEX STUB	
14	107-050	4	PRECISION DOWEL PIN (M12 X 30)	
15	400-1052	2	LOCK COLLAR	
16	106-478	8	SCREW (M16-2.00 X 40MM, 10.9)	
17	215-1004	1	SPEED PICKUP	

NOT SHOWN:

400-1221	-	SAVER SUB 2.77-4F SS	"AT" COBBLE PIPE
400-1222	-	SAVER SUB 2.77-4F SS	"AT" PIPE
214-048	4	PACKARD WP TERMINAL FEMALE	
157-645	4	WEATHER-PAC SEAL (2.80MM)	
215-227	1	4-WAY FEMALE W.P. CONNECTOR	

FOOTNOTES:

- 502-172 SPEED SENSOR
500-1426 SHAFT SEAL RING
- REFER TO ID0190151 FOR S/N: CMWJ30ATH70000017 THRU
- 117-300 SPRING TO BE USED ON OLD STYLE HEX STUB, ENDS WITH S/N: CMWJ30ATP70000024

NOTE:

SPINDLE DRIVE ASSEMBLY "AT"

BEGINS WITH S/N: CMWJ30ATC70000022

ENDS WITH S/N: CMWJ30ATK80000043

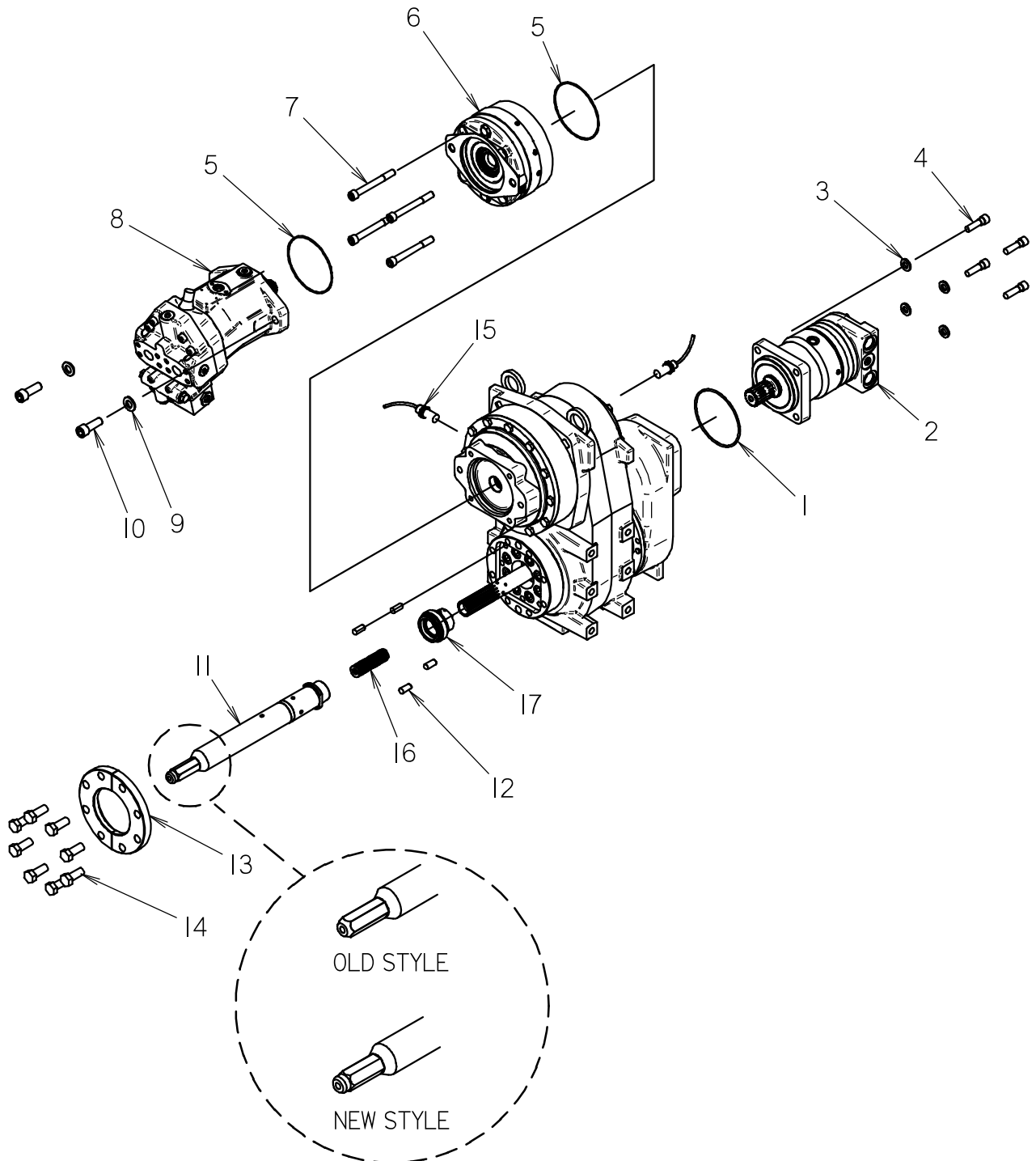

SPINDLE DRIVE ASSEMBLY "AT"

BEGINS WITH S/N: CMWJ30ATC70000022

ENDS WITH S/N: CMWJ30ATK80000043

REF NO.	PART NUMBER	QTY	DESCRIPTION	REMARKS
1	I55-770	1	O-RING (250 D70)	
2	I58-208	1	HYDRAULIC MOTOR	SEAL KIT I50-I04I
3	I06-397	4	WASHER (M12, HARDENED)	
4	I06-707	4	SCREW (M12-1.75 X 45MM, SOC)	
5	I57-084	2	O-RING (I59 D70)	
6	I60-I099	1	MODULAR BRAKE	
7	I07-495	4	BLT (I/2-NC X 4.50", SOC GD 8)	
8	I50-I992	1	HYDRAULIC MOTOR	SEE FOOTNOTE 1
9	I06-398	2	WASHER (M16, HARDENED)	
10	I05-997	2	BOLT (5/8-NC X I-3/4", SOC)	
11	400-I047	1	HEX STUB	SEE FOOTNOTE 2
12	I07-050	4	PRECISION DOWEL PIN (M12 X 30)	
13	400-I052	2	LOCK COLLAR	
14	I06-478	8	SCREW (M16-2.00 X 40MM, I0.9)	
15	215-I004	2	SPEED PICKUP	
16	I17-300	1	SPRING	SEE FOOTNOTE 2
17	I9I-34I	1	INNER WATER SWIVEL REPLACEMENT KIT	INCLUDES DOWEL PIN

NOT SHOWN:

400-I221 - SAVER SUB 2.77-4F SS
 400-I222 - SAVER SUB 2.77-4F SS

"AT" COBBLE PIPE
 "AT" PIPE

FOOTNOTES:

- 500-I426 SHAFT SEAL RING
- USE I05-I262 SPRING IF NEW STYLE 400-I047 HEX STUB IS IN USE

NOTE:

WATER SWIVEL

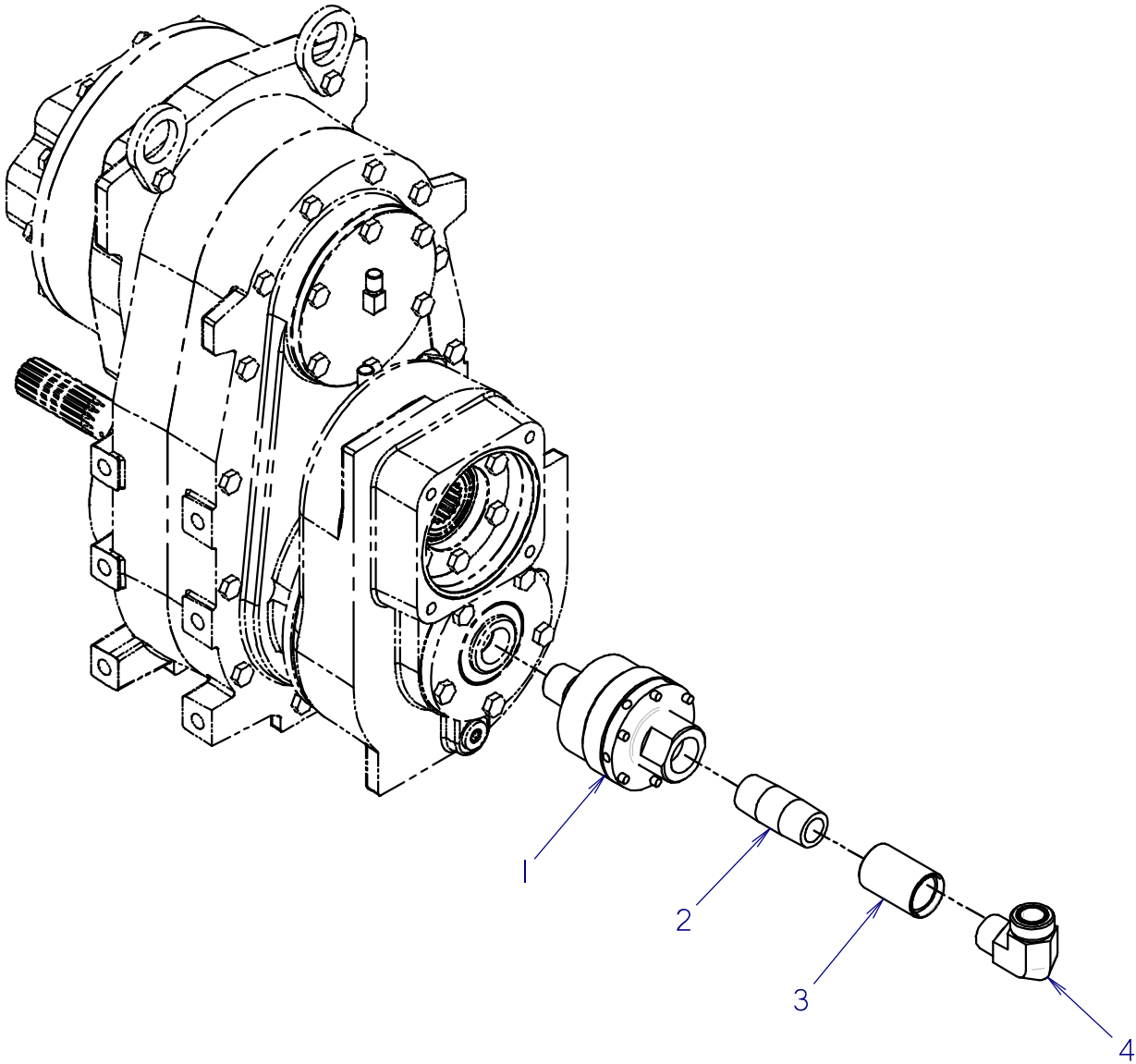

WATER SWIVEL

REF NO.	PART NUMBER	QTY	DESCRIPTION	REMARKS
1	159-382	1	WATER SWIVEL (16N-16NF)	SEE FOOTNOTE 1 & 2
2	150-1317	1	NIPPLE (16N-3")	FOR USE ON "AT" ONLY
3	150-1318	1	COLLAR (16NF)	FOR USE ON "AT" ONLY
4	510-011	1	CONNECTOR (16N-16090)	

NOT SHOWN:

FOOTNOTES:

1. INSTALL USING NICKLE THREAD SEALING TAPE (117-555) ON MALE THREADS
2. 190-905 SWIVEL REPAIR KIT

NOTE:

ROTATION GEAR BOX (JT)
 BEGINS WITH S/NCMWJ30M1L70000012
 ENDS WITH S/NCMWJ30M1E80000063

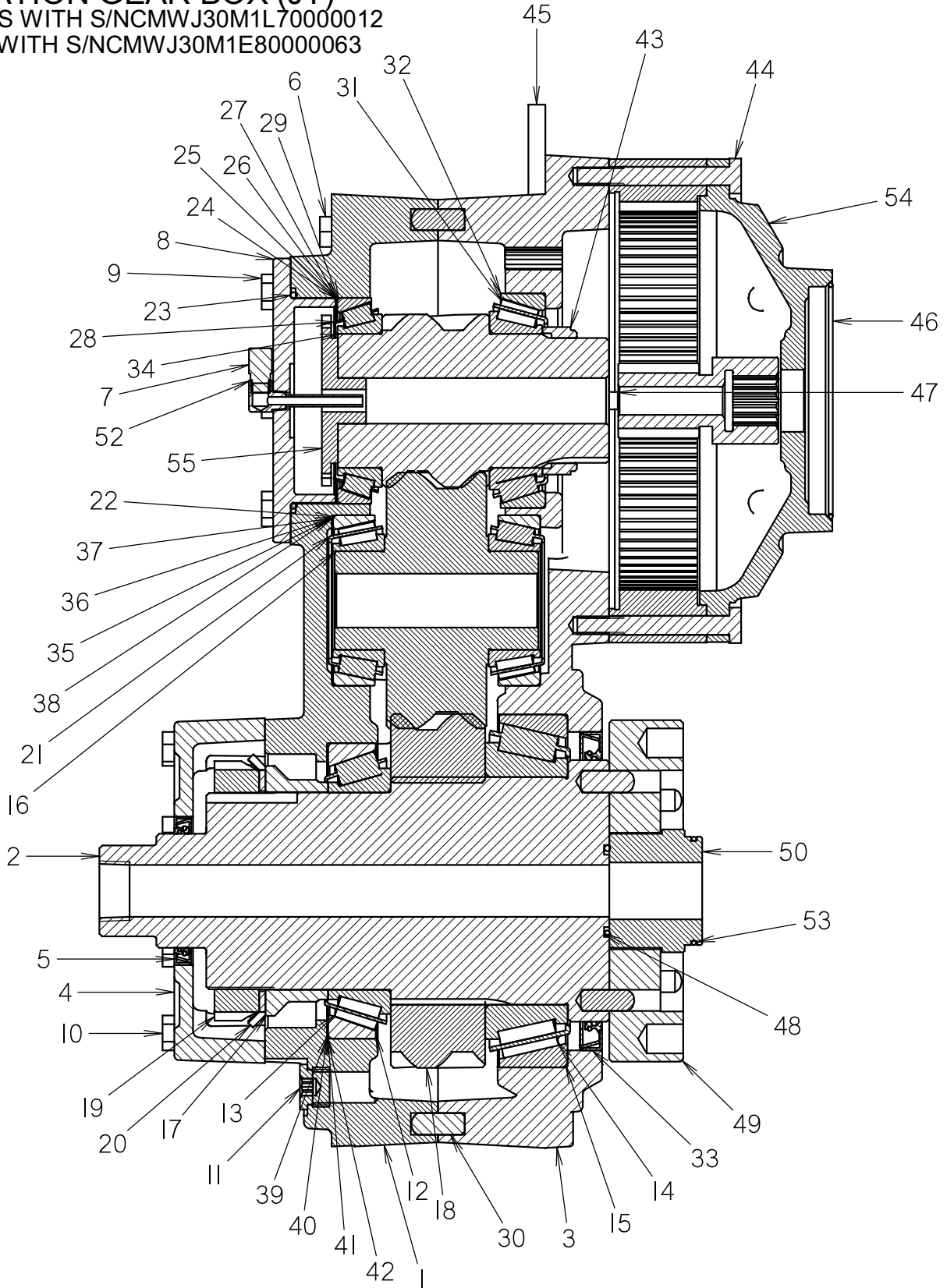

ROTATION GEAR BOX (JT)
BEGINS WITH S/NCMWJ30M1L70000012
ENDS WITH S/NCMWJ30M1E80000063

REF NO.	PART NUMBER	QTY	DESCRIPTION	REMARKS
	I66-1001	-	JT3020 ROTATION DRIVE ASSEMBLY (JT)	
1	329-437	1	COVER (MACHINE)	
2	166-610	1	OUTPUT SHAFT	
3	164-040	1	HOUSING (MACHINED)	
4	164-039	1	COVER PLATE	
5	153-638	1	Internal Seal	
6	106-617	14	SCREW (M10-1.50 X 80MM)	
7	159-003	1	AIR VENT (O2N)	
8	300-5279	1	BEARING AND SENSOR RETAINER	
9	105-245	8	SCREW (M10-1.50 X 25MM)	
10	106-142	8	SCREW (M10-1.50 X 65MM)	
11	155-179	1	PLUG (IOS, SOC)	
12	126-063	1	TAPERED RACE (6.496")	
13	126-064	1	TAPERED BEARING (4.330")	
14	125-542	1	TAPERED BEARING	
15	125-543	1	TAPERED RACE	
16	166-612	1	IDLER GEAR	
17	177-247	1	SPACER	
18	166-611	1	OUTPUT GEAR	
19	107-706	1	SPANNER NUT	USE LOCTITE 277, TORQUE TO 1750 FT-LBS
20	107-707	1	LOCK WASHER	
21	126-170	2	TAPERED BEARING (2.1654")	
22	126-171	2	TAPERED RACE	
23	157-633	1	O-RING (246 D70)	
24	117-535	1	SHIM	
25	117-536	1	SHIM	
26	117-537	1	SHIM	
27	179-309	1	SHIM (.020)	
28	126-013	1	TAPERED BEARING (2.952")	
29	126-012	1	TAPERED RACE (4.527")	
30	107-050	10	PRECISION DOWEL PIN (M12 X 30)	
31	125-306	1	BEARING (TAPERED ROLLER)	
32	125-307	1	BEARING RACE	
33	153-615	1	SEAL	
34	160-1009	1	PINION	
35	165-843	1	SHIM (.076MM)	
36	165-844	1	SHIM (.178MM)	
37	107-577	1	SHIM (.020)	

NOT SHOWN:

FOOTNOTES:

NOTE:

ROTATION GEAR BOX (JT)
BEGINS WITH S/NCMWJ30M1L70000012
ENDS WITH S/NCMWJ30M1E80000063

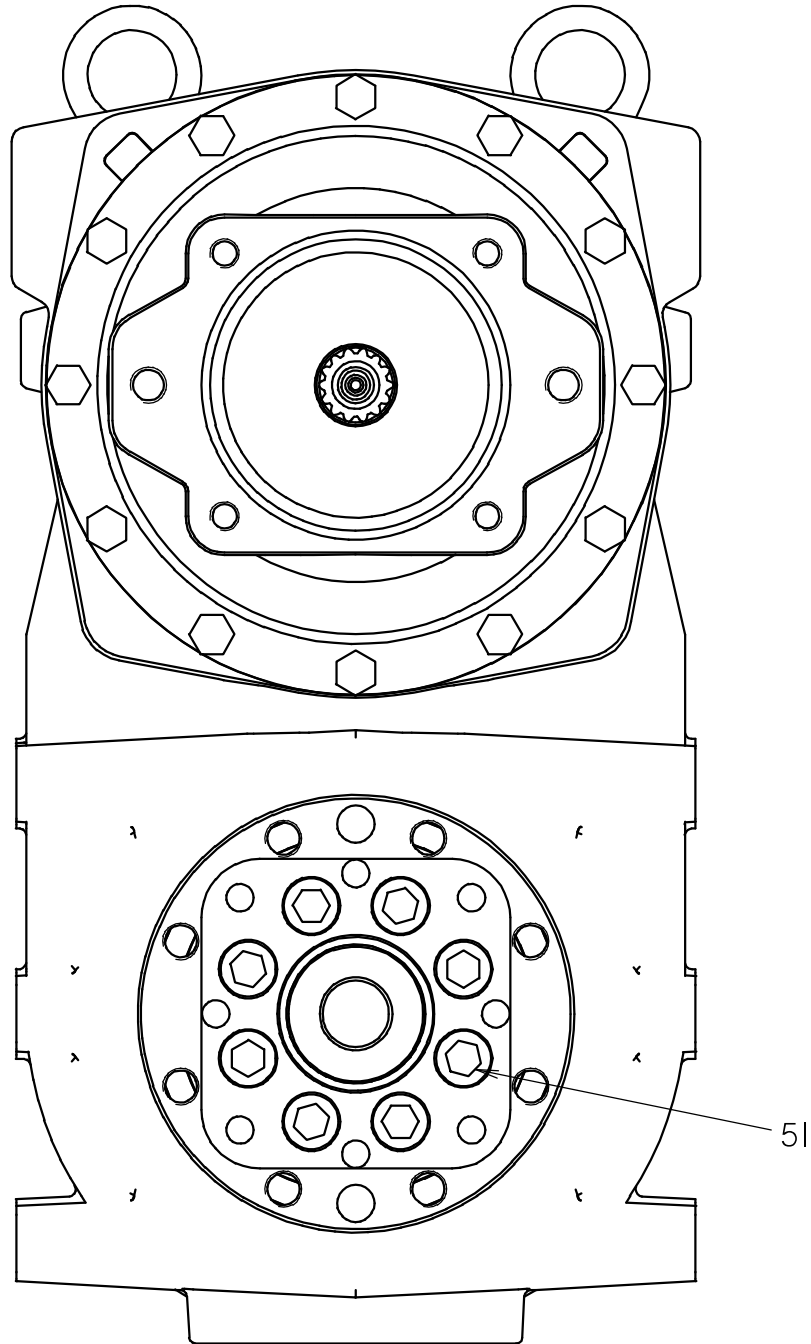

ROTATION GEAR BOX (JT)
BEGINS WITH S/NCMWJ30M1L70000012
ENDS WITH S/NCMWJ30M1E80000063

REF NO.	PART NUMBER	QTY	DESCRIPTION	REMARKS
38	165-842	1	SHIM (.051MM)	
39	165-804	1	SHIM (.003)	
40	165-805	1	SHIM (.007)	
41	107-576	1	SHIM (.020)	
42	165-803	1	SHIM (.051MM)	
43	300-2017	1	SPACER	
44	107-982	12	HHCS M10-1.50 X 85MM,10.9 ZP	
45	300-2536	2	LIFT EYE	
46	157-084	1	O-RING (159 D70)	
47	105-534	3	DOWEL PIN (.375" X .875")	
48	157-022	1	O-RING (224 D90)	
49	300-2393	1	FLANGE	
50	300-2413	1	SEAL CONTAINER	
51	106-681	8	SCREW (M16-2.00 X 35MM, SOC)	USE LOCTITE 242 OR 243, TORQUE TO 200 FT-LBS
52	514-123	1	PICKUP TUBE (02N-02NF90-2')	
53	157-019	1	O-RING (139 D90)	
54	166-152	1	ROTATION GEAR BOX PLANETARY	
55	160-1104	1	SPEED SENSOR RING - 36T	

NOT SHOWN:

110-111 1 SIGHT GAUGE (16S)
 155-748 1 O-RING (916 D90)
 106-866 2 DOWEL PIN (M10 x 30MM)

USED ON 110-111 SIGHT GAUGE
 USE TO SET 329-437 COVER & 164-039 COVER PLATE

FOOTNOTES:

NOTE:

ROTATION GEAR BOX (JT)
 ENDS WITH S/NCMWJ30M1A70000011
 BEGINS WITH S/NCMWJ30M1C80000064

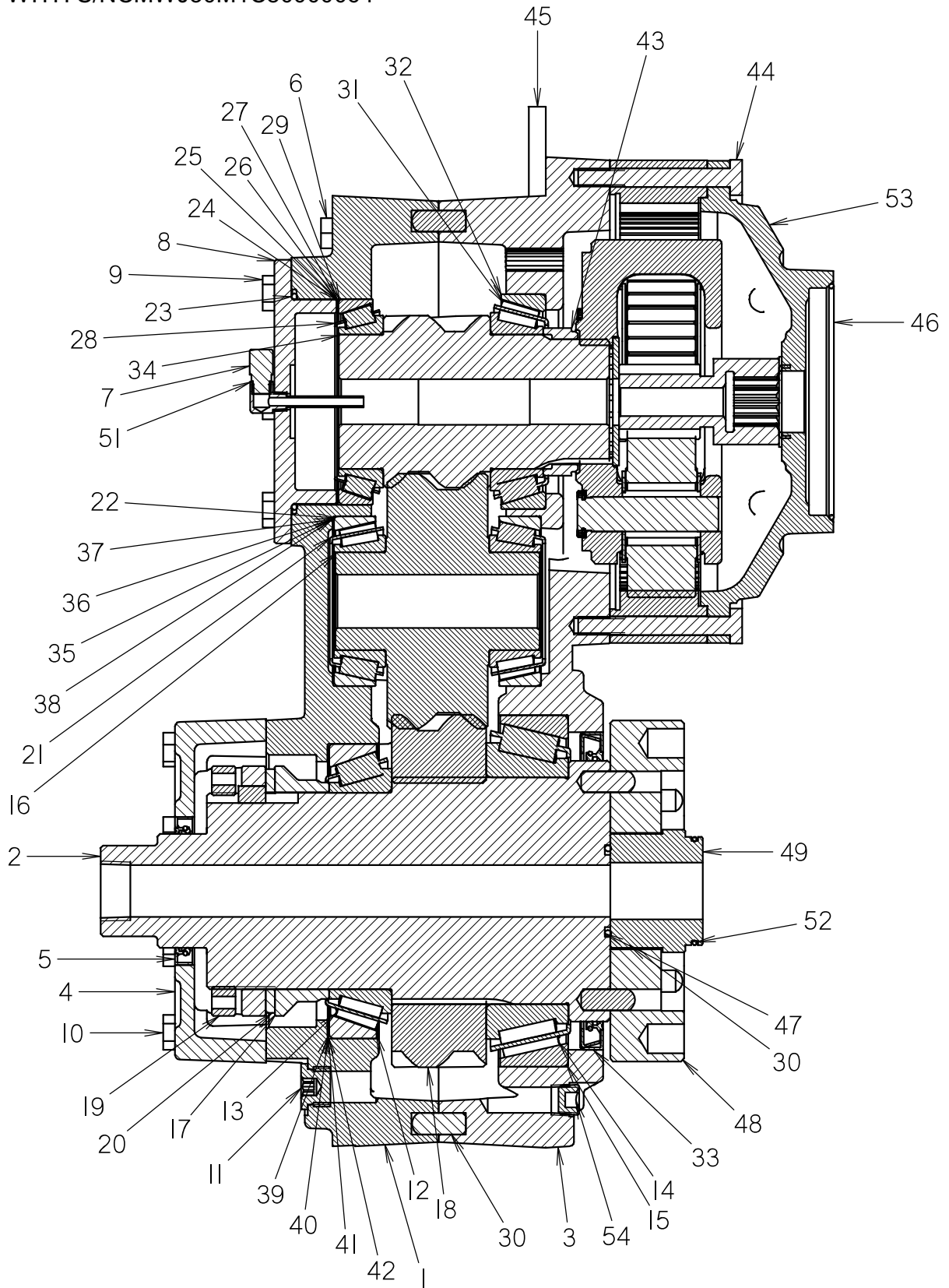

ROTATION GEAR BOX (JT)
ENDS WITH S/NCMWJ30M1A70000011
BEGINS WITH S/NCMWJ30M1C80000064

REF NO.	PART NUMBER	QTY	DESCRIPTION	REMARKS
	I66-I001	-	JT3020 ROTATION DRIVE ASSEMBLY (JT)	
1	329-437	1	COVER (MACHINE)	
2	I66-610	1	OUTPUT SHAFT	
3	I64-040	1	HOUSING (MACHINED)	
4	I64-039	1	COVER PLATE	
5	I53-638	1	Internal Seal	
6	I06-617	14	SCREW (M10-I.50 X 80MM)	
7	I59-003	1	AIR VENT (O2N)	
8	300-I095	1	BEARING RETAINER	
9	I05-245	8	SCREW (M10-I.50 X 25MM)	
10	I06-I42	8	SCREW (M10-I.50 X 65MM)	
11	I55-I79	1	PLUG (IOS, SOC)	
12	I26-063	1	TAPERED RACE (6.496")	
13	I26-064	1	TAPERED BEARING (4.330")	
14	I25-542	1	TAPERED BEARING	
15	I25-543	1	TAPERED RACE	
16	I66-612	1	IDLER GEAR	32 TEETH
17	300-7824	1	SPACER	
18	I66-611	1	OUTPUT GEAR	45 TEETH
19	I60-I115	1	NUT ASSEMBLY	SEE FOOTNOTE 1
20	I05-I313	1	WASHER	
21	I26-I70	2	TAPERED BEARING (2.1654")	
22	I26-I71	2	TAPERED RACE	
23	I57-633	1	O-RING (246 D70)	
24	I17-535	1	SHIM	
25	I17-536	1	SHIM	
26	I17-537	1	SHIM	
27	I79-309	1	SHIM (.020)	
28	I26-013	1	TAPERED BEARING (2.952")	
29	I26-012	1	TAPERED RACE (4.527")	
30	I07-050	10	PRECISION DOWEL PIN (M12 X 30)	
31	I25-306	1	BEARING (TAPERED ROLLER)	
32	I25-307	1	BEARING RACE	
33	I53-615	1	INTERNAL SEAL (5.750" ID)	
34	I60-I009	1	PINION	21 TEETH
35	I65-843	1	SHIM (.076MM)	
36	I65-844	1	SHIM (.178MM)	
37	I07-577	1	SHIM (.020)	

NOT SHOWN:

FOOTNOTES:

NOTE:

ROTATION GEAR BOX (JT)
ENDS WITH S/NCMWJ30M1A70000011
BEGINS WITH S/NCMWJ30M1C80000064

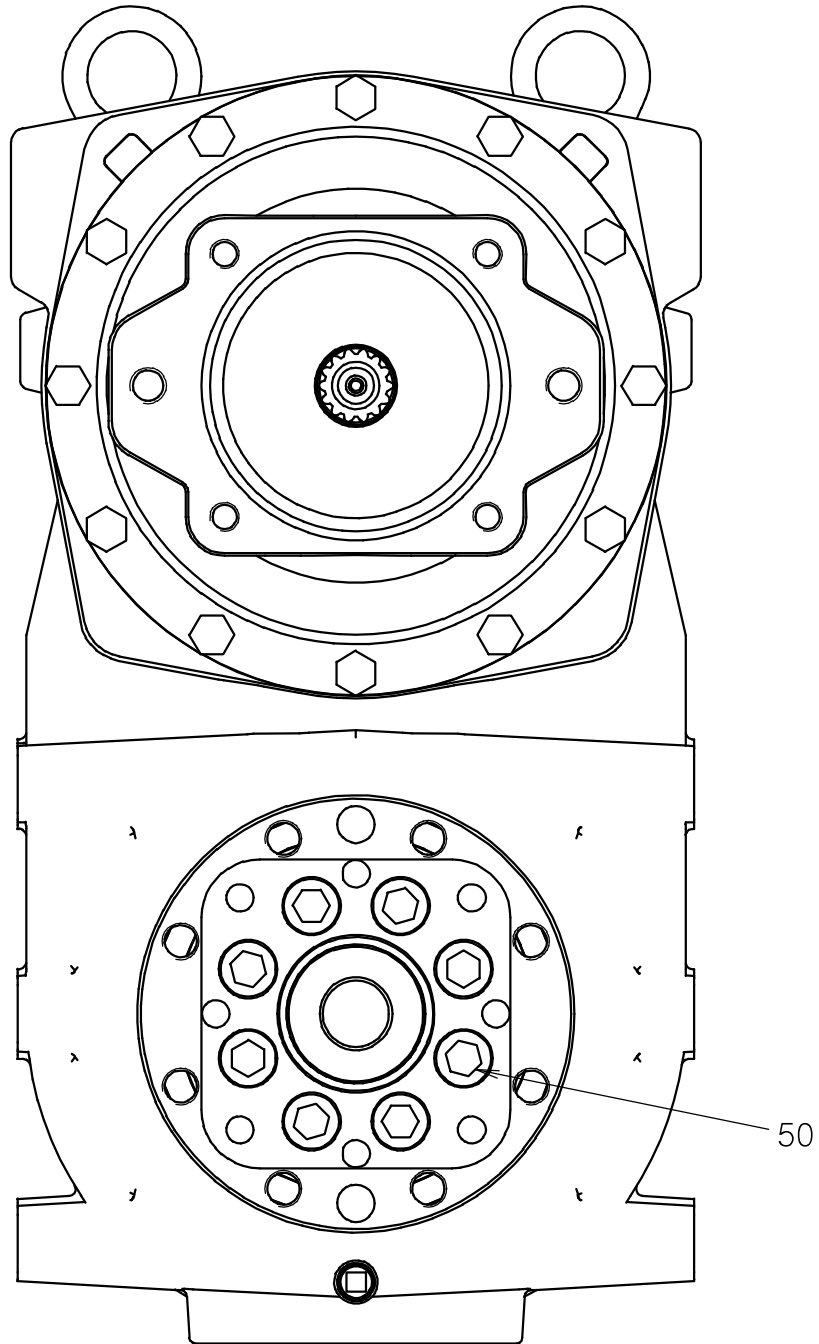

ROTATION GEAR BOX (JT)
ENDS WITH S/NCMWJ30M1A70000011
BEGINS WITH S/NCMWJ30M1C80000064

REF NO.	PART NUMBER	QTY	DESCRIPTION	REMARKS
38	165-842	1	SHIM (.051MM)	
39	165-804	1	SHIM (.003)	
40	165-805	1	SHIM (.007)	
41	107-576	1	SHIM (.020)	
42	165-803	1	SHIM (.051MM)	
43	300-2017	1	SPACER	
44	107-982	12	HHCS M10-1.50 X 85MM,10.9 ZP	
45	300-2536	2	LIFT EYE	
46	157-084	1	O-RING (159 D70)	
47	157-022	1	O-RING (224 D90)	
48	300-2393	1	FLANGE	
49	300-2413	1	SEAL CONTAINER	
50	106-681	8	SCREW (M16-2.00 X 35MM, SOC)	USE LOCTITE 242 OR 243, TORQUE TO 200 FT-LBS
51	514-123	1	PICKUP TUBE (02N-02NF90-2')	
52	157-019	1	O-RING (139 D90)	
53	166-152	1	ROTATION GEAR BOX PLANETARY	
54	115-178	1	PLUG (06N, SQ FM)	

NOT SHOWN:

110-111	1	SIGHT GAUGE (16S)	
155-748	1	O-RING (916 D90)	USED ON 110-111 SIGHT GAUGE
106-866	2	DOWEL PIN (M10 x 30MM)	USE TO SET 329-437 COVER & 164-039 COVER PLATE
105-534	3	DOWEL PIN (.375" X .875")	USED ON 164-040 HOUSING TO SET 166-152 ROTATION GEAR BOX
499-893	1	THRUST WASHER	USED BETWEEN PLANETARY INPUT GEAR AND HOUSING

FOOTNOTES:

- I. USE KIT 190-1386 GEARBOX NUT, INCLUDES 255-1006 MOLLY PASTE (SINGLE APPLICATION)

NOTE:

ROTATION GEAR BOX (AT)

BEGINS WITH S/N CMWJ30ATEB0000304

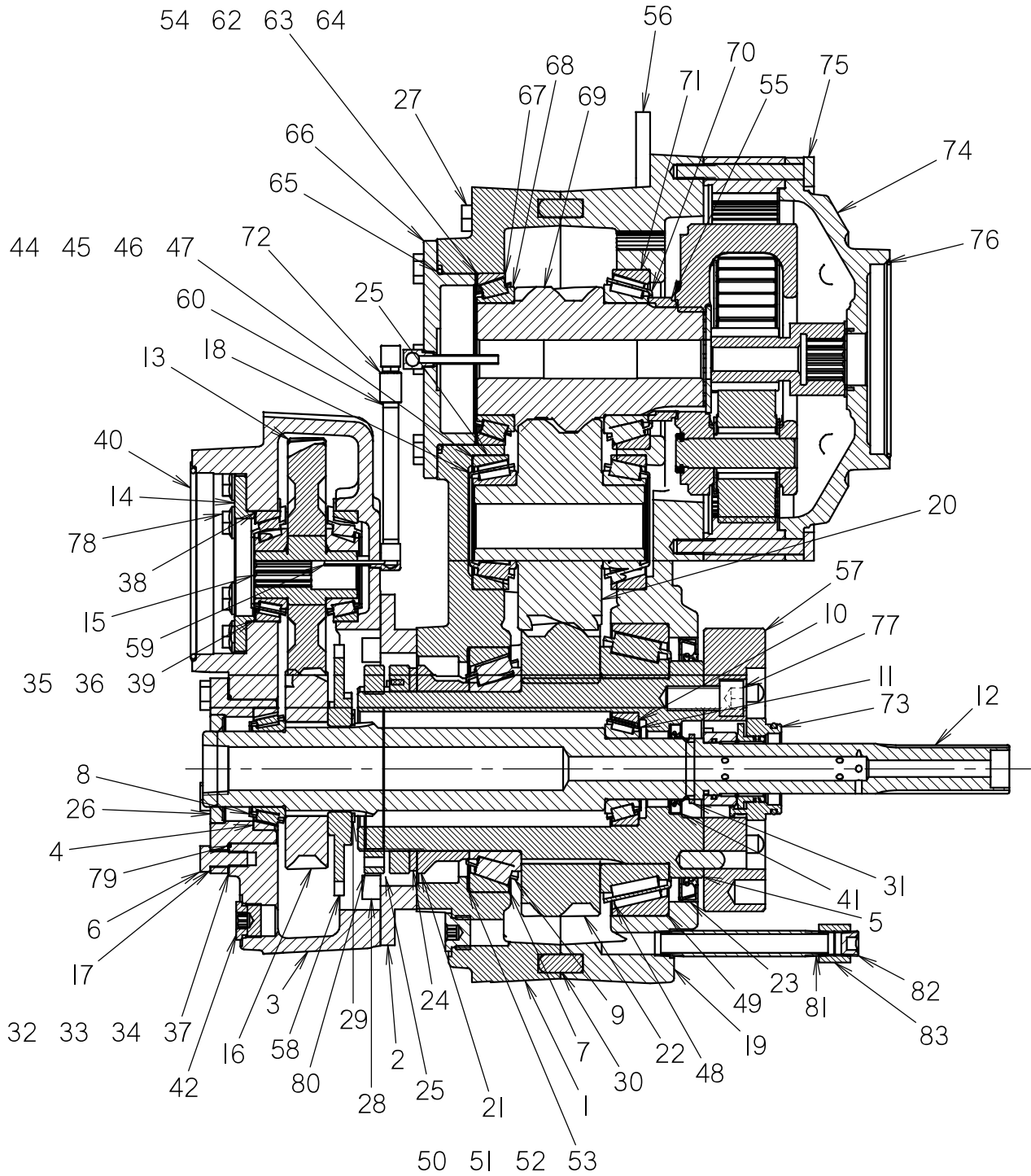

ROTATION GEAR BOX (AT)

BEGINS WITH S/N CMWJ30ATEB0000304

REF NO.	PART NUMBER	QTY	DESCRIPTION	REMARKS
	I66-I002	-	JT3020 ROTATION DRIVE (AT)	
1	329-437	1	COVER (MACHINE)	
2	329-397	1	ADAPTER	
3	I66-633	1	GEARBOX - MACHINED	
4	I26-099	3	TAPERED RACE (3.25")	
5	I66-625	1	OUTPUT SHAFT	
6	I05-245	14	SCREW (M10-1.50 X 25MM)	
7	I26-063	1	TAPERED RACE (6.496")	
8	I26-100	3	BEARING CONE	
9	I26-064	1	TAPERED BEARING (4.330")	
10	I25-249	1	TAPERED CUP (3.0000")	
11	I25-248	1	TAPERED BEARING (1.6250")	
12	I60-1040	1	INNER SHAFT	
13	I66-628	1	PINION	37 TEETH
14	I77-272	1	RETAINER PLATE	
15	I66-627	1	SHAFT	
16	I66-626	1	INNER GEAR	30 TEETH
17	I78-438	1	BEARING RETAINER	
18	I26-170	2	TAPERED BEARING (2.1654")	
19	I64-040	1	HOUSING (MACHINED)	
20	I66-612	1	IDLER GEAR	32 TEETH
21	I77-247	1	SPACER	
22	I66-611	1	OUTPUT GEAR	45 TEETH
23	I53-615	1	INTERNAL SEAL (5.750" ID)	
24	I05-1313	1	HARDENED WASHER	
25	I26-171	2	TAPERED RACE	USE LOCTITE 277, TORQUE TO 1750 FT-LBS
26	I57-501	1	INTERNAL SEAL	
27	I06-617	14	SCREW (M10-1.50 X 80MM)	
28	I06-544	8	SCREW (M10-1.50 X 40MM, SOC)	
29	I15-457	1	EXTERNAL SNAP RING (2.5")	
30	I07-050	10	PRECISION DOWEL PIN (M12 X 30)	
31	I50-1293	1	SEAL, V-RING	
32	I07-579	1	SHIM (.020")	
33	I07-487	1	SHIM (.007")	
34	I07-486	1	SHIM (.003")	
35	I65-801	1	SHIM (.003")	
36	I65-802	1	SHIM (.007")	
37	I07-485	1	SHIM (.002")	
38	I65-800	1	SHIM (.002")	
39	I07-575	1	SHIM (.020")	
40	I55-770	1	O-RING (250 D70)	
41	I53-153	1	INTERNAL SEAL	
42	I55-179	2	PLUG (10S, SOC)	
43	I59-003	2	AIR VENT (02N)	
44	I65-842	1	SHIM (.051MM)	
45	I65-843	1	SHIM (.076MM)	
46	I65-844	1	SHIM (.178MM)	
47	I07-577	1	SHIM (.020)	
48	I25-542	1	TAPERED BEARING	

NOT SHOWN:

FOOTNOTES:

ROTATION GEAR BOX (AT)

BEGINS WITH S/N CMWJ30ATEB0000304

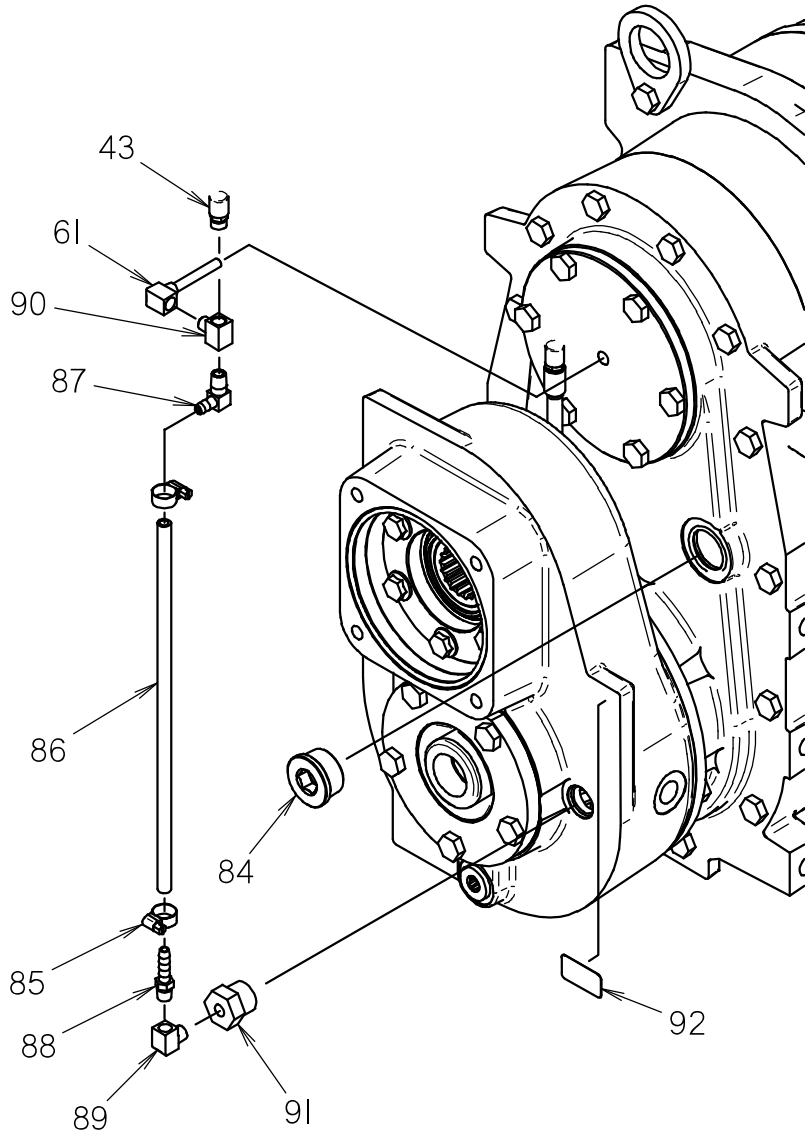

ROTATION GEAR BOX (AT) BEGINS WITH S/N CMWJ30ATEB0000304

REF NO.	PART NUMBER	QTY	DESCRIPTION	REMARKS
49	125-543	1	TAPERED RACE	
50	165-803	1	SHIM (.051MM)	
51	165-804	1	SHIM (.003)	
52	165-805	1	SHIM (.007)	
53	107-576	1	SHIM (.020)	
54	179-309	1	SHIM (.020)	
55	300-2017	1	SPACER	
56	300-2536	2	LIFT EYE	
57	300-2393	1	FLANGE	
58	160-1078	1	SPEED SENSOR RING - 36T	
59	150-1607	1	PICKUP TUBE (02N-02NF90-1.5")	
60	115-188	1	NIPPLE (02N-4.250")	
61	514-123	1	PICKUP TUBE (02N-02NF90-2")	
62	117-535	1	SHIM	
63	117-536	1	SHIM	
64	117-537	1	SHIM	
65	157-633	1	O-RING (246 D70)	
66	300-1095	1	BEARING RETAINER	
67	126-012	1	TAPERED RACE (4.527")	
68	126-013	1	TAPERED BEARING (2.952")	
69	160-1009	1	PINION	
70	125-306	1	BEARING (TAPERED ROLLER)	
71	125-307	1	BEARING RACE	
72	115-172	1	COLLAR (02NF-02NF)	21 TEETH
73	191-341	1	INNER WATER SWIVEL REPLACEMENT KIT	
74	166-152	1	ROTATION GEAR BOX PLANETARY	
75	107-982	12	HHCS M10-1.50 X 85MM,10.9 ZP	
76	157-084	1	O-RING (159 D70)	SEE FOOTNOTE I
77	106-681	8	SCREW (M16-2.00 X 35MM, SOC)	
78	107-001	6	FLG LK SCREW (M10-1.50 X 25MM)	
79	155-800	1	O-RING (045 D70)	
80	160-1115	1	NUT ASSEMBLY	
81	105-1353	1	PIPE NIPPLE (3/8" X 4.41")	USE LOCTITE 242 OR 243, TORQUE TO 200 FT-LBS
82	115-178	1	PLUG (06N, SQ FM)	
83	150-2320	1	COUPLER (3/8-NPT X 1 OD, STR)	
84	155-184	1	PLUG (16S, SOC, FM)	INCLUDES O-RING
85	110-249	2	WORM CLAMP (1/4" TO 5/8")	
86	117-902	1	BULK TUBING (1/4" SOLD PER 1')	USE 12"
87	155-158	1	S/O COUPLER (02N-04H90)	
88	155-107	1	COUPLER (1/8NPTX1/4OD,STR)	
89	156-241	1	STREET ELBOW (02N-02NF90)	
90	154-1001	1	MALE BRANCH TEE (02N-02N-02N)	
91	514-402	1	CONNECTOR (10S-02NF)	
92	275-023	1	OIL LEVEL DECAL	

NOT SHOWN:

155-748	1	O-RING (1916 D90)	USED ON 155-184 PLUG (16S)
106-866	4	DOWEL PIN (M10 X 30MM)	USED TO SET 329-397 ADAPTER TO 329-437 COVER & 166-633 GEARBOX
105-534	3	DOWEL PIN (.375" X .875")	USED ON 164-040 HOUSING TO SET 166-152 ROTATION GEAR BOX
190-1696		GEARBOX SIGHT TUBE KIT, JT3020	INCLUDES REF NO.'S 84-92

FOOTNOTES:

- I. INCLUDES 107-803 PIN .125 X .25 IN CASE NEW ONE IS NEEDED TO BE USED ON 160-1040 INNER SHAFT TO SET REF #76 INNER WATER SWIVEL REPLACEMENT KIT. 191-257 SEAL REPAIR KIT (157-469) REPLACEMENT O-RING KIT IS NOT INCLUDED.

ROTATION GEAR BOX (AT)

ENDS WITH S/N CMWJ30ATHB0000303

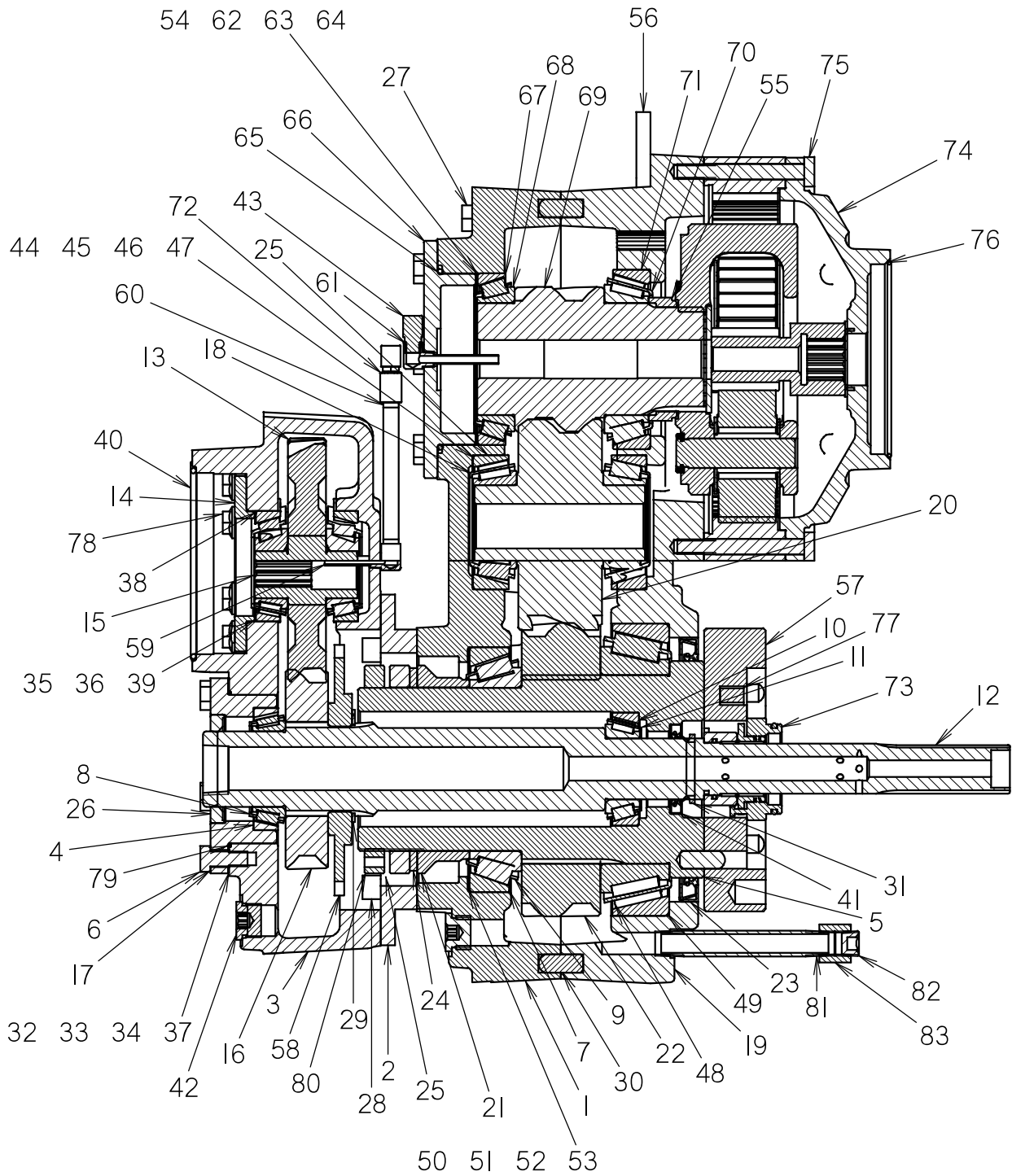

ROTATION GEAR BOX (AT) ENDS WITH S/N CMWJ30ATHB0000303

REF NO.	PART NUMBER	QTY	DESCRIPTION	REMARKS
	I66-I002	-	JT3020 ROTATION DRIVE (AT)	
1	329-437	1	COVER (MACHINE)	
2	329-397	1	ADAPTER	
3	I66-633	1	GEARBOX - MACHINED	
4	I26-099	3	TAPERED RACE (3.25")	
5	I66-625	1	OUTPUT SHAFT	
6	I05-245	14	SCREW (M10-1.50 X 25MM)	
7	I26-063	1	TAPERED RACE (6.496")	
8	I26-100	3	BEARING CONE	
9	I26-064	1	TAPERED BEARING (4.330")	
10	I25-249	1	TAPERED CUP (3.0000")	
11	I25-248	1	TAPERED BEARING (1.6250")	
12	I60-1040	1	INNER SHAFT	
13	I66-628	1	PINION	37 TEETH
14	I77-272	1	RETAINER PLATE	
15	I66-627	1	SHAFT	
16	I66-626	1	INNER GEAR	30 TEETH
17	I78-438	1	BEARING RETAINER	
18	I26-170	2	TAPERED BEARING (2.1654")	
19	I64-040	1	HOUSING (MACHINED)	
20	I66-612	1	IDLER GEAR	32 TEETH
21	I77-247	1	SPACER	
22	I66-611	1	OUTPUT GEAR	45 TEETH
23	I53-615	1	SEAL	
24	I05-1313	1	WASHER	
25	I26-171	2	TAPERED RACE	USE LOCTITE 277, TORQUE TO 1750 FT-LBS
26	I57-501	1	INTERNAL SEAL	
27	I06-617	14	SCREW (M10-1.50 X 80MM)	
28	I06-544	8	SCREW (M10-1.50 X 40MM, SOC)	
29	I15-457	1	EXTERNAL SNAP RING (2.5")	
30	I07-050	10	PRECISION DOWEL PIN (M12 X 30)	
31	I50-1293	1	SEAL, V-RING	
32	I07-579	1	SHIM (.020")	
33	I07-487	1	SHIM (.007")	
34	I07-486	1	SHIM (.003")	
35	I65-801	1	SHIM (.003")	
36	I65-802	1	SHIM (.007")	
37	I07-485	1	SHIM (.002")	
38	I65-800	1	SHIM (.002")	
39	I07-575	1	SHIM (.020")	
40	I55-770	1	O-RING (250 D70)	
41	I53-153	1	INTERNAL SEAL	
42	I55-179	3	PLUG (10S, SOC)	

NOT SHOWN:

FOOTNOTES:

NOTE:

ROTATION GEAR BOX (AT)
ENDS WITH S/N CMWJ30ATHB0000303

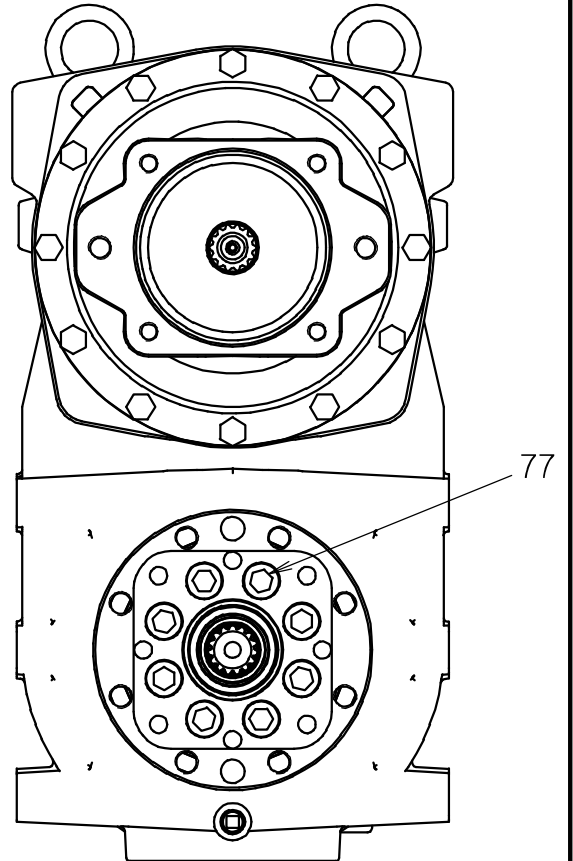
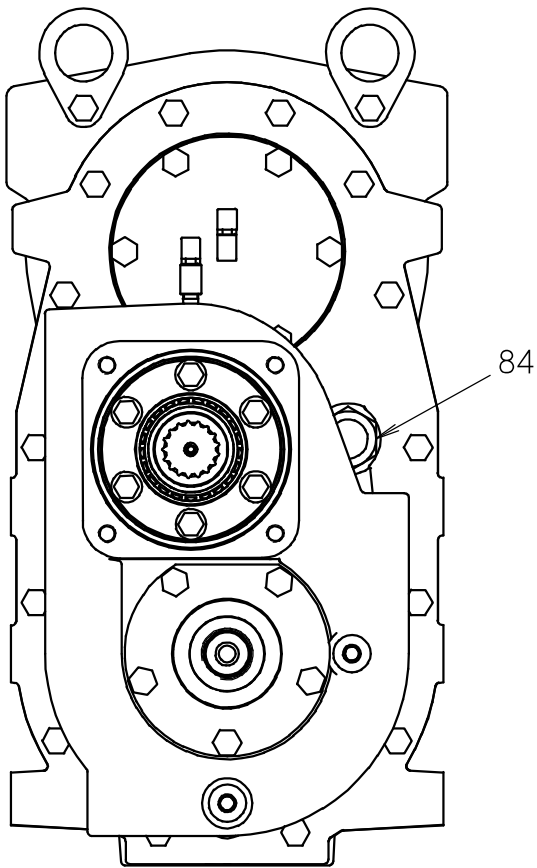

ROTATION GEAR BOX (AT) ENDS WITH S/N CMWJ30ATHB0000303

REF NO.	PART NUMBER	QTY	DESCRIPTION	REMARKS
43	159-003	2	AIR VENT (02N)	
44	165-842	1	SHIM (.051MM)	
45	165-843	1	SHIM (.076MM)	
46	165-844	1	SHIM (.178MM)	
47	107-577	1	SHIM (.020)	
48	125-542	1	TAPERED BEARING	
49	125-543	1	TAPERED RACE	
50	165-803	1	SHIM (.051MM)	
51	165-804	1	SHIM (.003)	
52	165-805	1	SHIM (.007)	
53	107-576	1	SHIM (.020)	
54	179-309	1	SHIM (.020)	
55	300-2017	1	SPACER	
56	300-2536	2	LIFT EYE	
57	300-2393	1	FLANGE	
58	160-1078	1	SPEED SENSOR RING - 36T	
59	150-1607	1	PICKUP TUBE (02N-02NF90-1.5")	
60	115-188	1	NIPPLE (02N-4.250")	
61	514-123	1	PICKUP TUBE (02N-02NF90-2")	
62	117-535	1	SHIM	
63	117-536	1	SHIM	
64	117-537	1	SHIM	
65	157-633	1	O-RING (246 D70)	
66	300-1095	1	BEARING RETAINER	
67	126-012	1	TAPERED RACE (4.527")	
68	126-013	1	TAPERED BEARING (2.952")	
69	160-1009	1	PINION	
70	125-306	1	BEARING (TAPERED ROLLER)	
71	125-307	1	BEARING RACE	
72	115-172	1	COLLAR (02NF-02NF)	21 TEETH
73	191-341	1	INNER WATER SWIVEL REPLACEMENT KIT	
74	166-152	1	ROTATION GEAR BOX PLANETARY	
75	107-982	12	HHCS M10-1.50 X 85MM, I0.9 ZP	
76	157-084	1	O-RING (159 D70)	SEE FOOTNOTE 1
77	106-681	8	SCREW (M16-2.00 X 35MM, SOC)	
78	107-001	6	FLG LK SCREW (M10-1.50 X 25MM)	
79	155-800	1	O-RING (045 D70)	
80	160-1115	1	NUT ASSEMBLY	
81	105-1353	1	PIPE NIPPLE (3/8" X 4.41")	USE LOCTITE 242 OR 243, TORQUE TO 200 FT-LBS
82	115-178	1	PLUG (06N, SQ FM)	
83	150-2320	1	COUPLER (3/8-NPT X 1 OD, STR)	
84	110-111	1	SIGHT GAUGE (16S)	

NOT SHOWN:

110-111	1	SIGHT GAUGE (6S)	
155-748	1	O-RING (916 D90)	USED ON 110-111 SIGHT GAUGE
106-866	4	DOWEL PIN (M10 X 30MM)	USED TO SET 329-397 ADAPTER TO 329-437 COVER & 166-633 GEARBOX
105-534	3	DOWEL PIN (.375" X .875")	USED ON 164-040 HOUSING TO SET 166-152 ROTATION GEAR BOX

FOOTNOTES:

- INCLUDES 107-803 PIN .125 X .25 IN CASE NEW ONE IS NEEDED TO BE USED ON 160-1040 INNER SHAFT TO SET REF #76 INNER WATER SWIVEL REPLACEMENT KIT. 191-257 SEAL REPAIR KIT (157-469) REPLACEMENT O-RING KIT IS NOT INCLUDED.

NOTE:

ROTATION GEAR BOX (AT)
ENDS WITH S/N; CMWJ30ATE70000021
BEGINS WITH S/N; CMWJ30ATJ80000044

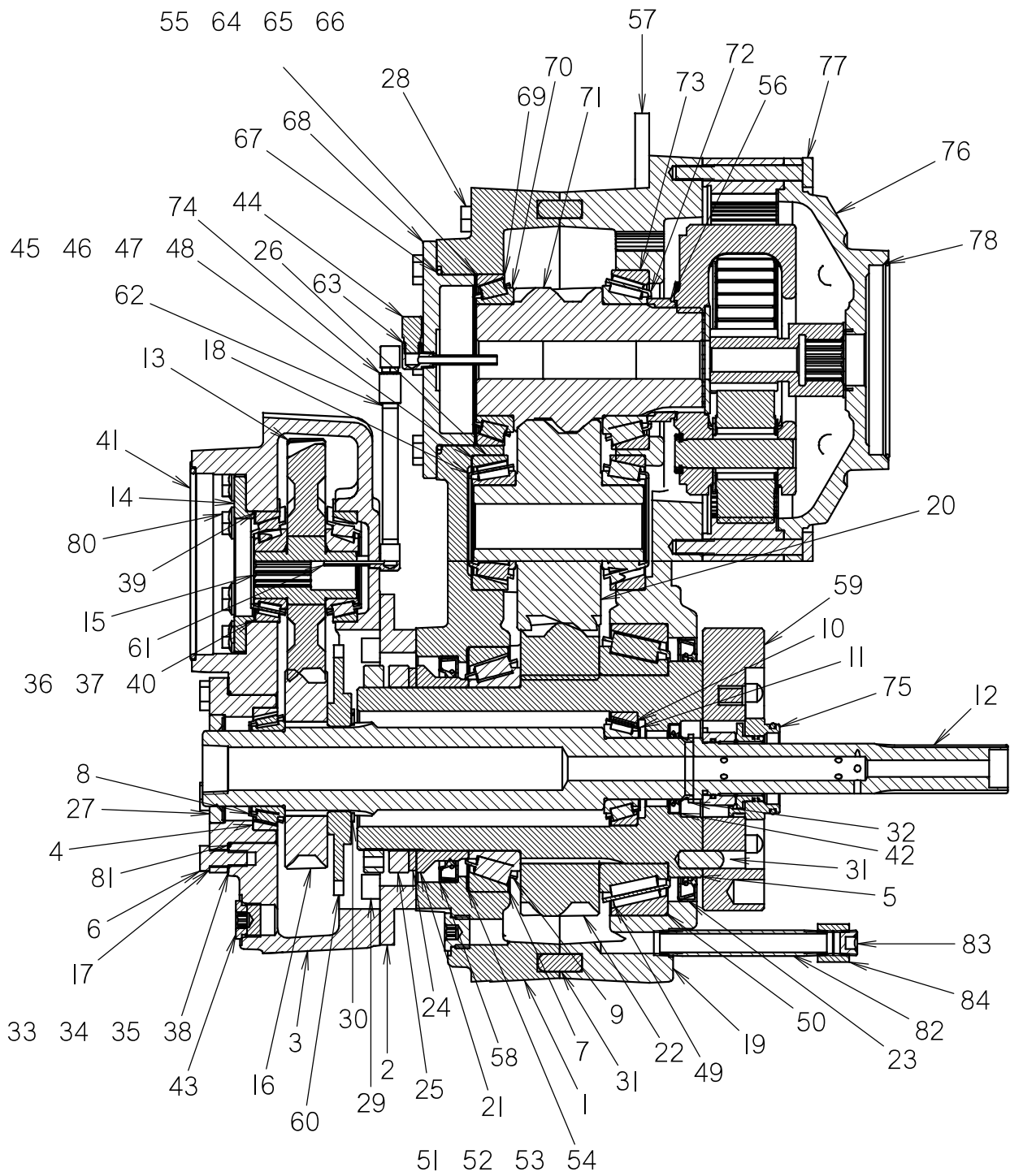

ROTATION GEAR BOX (AT)
ENDS WITH S/N; CMWJ30ATE70000021
BEGINS WITH S/N; CMWJ30ATJ80000044

REF NO.	PART NUMBER	QTY	DESCRIPTION	REMARKS
	I66-I002	-	JT3020 ROTATION DRIVE (AT)	
1	329-437	1	COVER (MACHINE)	
2	329-397	1	ADAPTER	
3	I66-633	1	GEARBOX - MACHINED	
4	I26-099	3	TAPERED RACE (3.25")	
5	I66-625	1	OUTPUT SHAFT	
6	I05-245	14	SCREW (M10-1.50 X 25MM)	
7	I26-063	1	TAPERED RACE (6.496")	
8	I26-100	3	BEARING CONE	
9	I26-064	1	TAPERED BEARING (4.330")	
10	I25-249	1	TAPERED CUP (3.0000")	
11	I25-248	1	TAPERED BEARING (1.6250")	
12	I60-I040	1	INNER SHAFT	
13	I66-628	1	PINION	37 TEETH
14	I77-272	1	RETAINER PLATE	
15	I66-627	1	SHAFT	
16	I66-626	1	INNER GEAR	30 TEETH
17	I78-438	1	BEARING RETAINER	
18	I26-I70	2	TAPERED BEARING (2.1654")	
19	I64-040	1	HOUSING (MACHINED)	
20	I66-612	1	IDLER GEAR	32 TEETH
21	I77-247	1	SPACER	
22	I66-611	1	OUTPUT GEAR	45 TEETH
23	I53-615	1	SEAL	
24	I05-I313	1	WASHER	
25	I60-III5	1	NUT ASSEMBLY	SEE FOOTNOTE 2
26	I26-I71	2	TAPERED RACE	
27	I57-501	1	INTERNAL SEAL	
28	I06-617	14	SCREW (M10-1.50 X 80MM)	
29	I06-544	8	SCREW (M10-1.50 X 40MM, SOCI)	
30	I15-457	1	EXTERNAL SNAP RING (2.5")	
31	I07-050	10	PRECISION DOWEL PIN (M12 X 30)	
32	I50-I293	1	SEAL, V-RING	
33	I07-579	1	SHIM (.020")	
34	I07-487	1	SHIM (.007")	
35	I07-486	1	SHIM (.003")	
36	I65-801	1	SHIM (.003")	
37	I65-802	1	SHIM (.007")	
38	I07-485	1	SHIM (.002")	
39	I65-800	1	SHIM (.002")	
40	I07-575	1	SHIM (.020")	
41	I55-770	1	O-RING (250 D70)	
42	I53-I53	1	INTERNAL SEAL	

NOT SHOWN:

FOOTNOTES:

NOTE:

ROTATION GEAR BOX (AT)
ENDS WITH S/N; CMWJ30ATE70000021
BEGINS WITH S/N; CMWJ30ATJ80000044

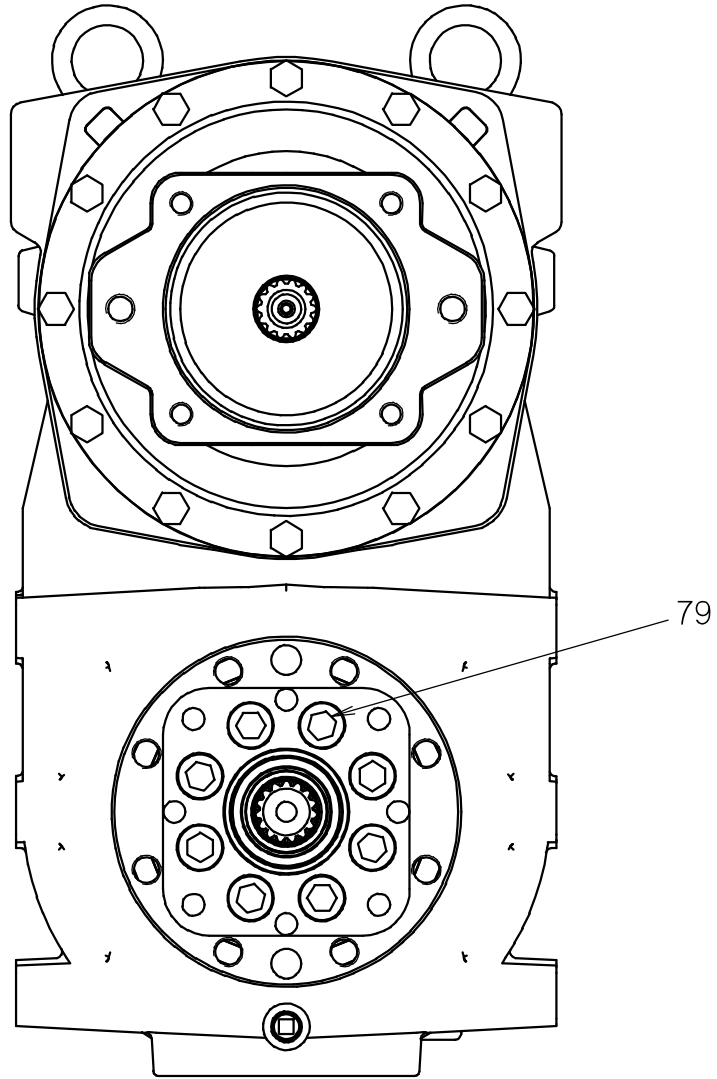

ROTATION GEAR BOX (AT)
ENDS WITH S/N; CMWJ30ATE70000021
BEGINS WITH S/N; CMWJ30ATJ80000044

REF NO.	PART NUMBER	QTY	DESCRIPTION	REMARKS
43	155-179	3	PLUG (10S, SOC)	
44	159-003	2	AIR VENT (02N)	
45	165-842	1	SHIM (.051MM)	
46	165-843	1	SHIM (.076MM)	
47	165-844	1	SHIM (.178MM)	
48	107-577	1	SHIM (.020)	
49	125-542	1	TAPERED BEARING	
50	125-543	1	TAPERED RACE	
51	165-803	1	SHIM (.051MM)	
52	165-804	1	SHIM (.003)	
53	165-805	1	SHIM (.007)	
54	107-576	1	SHIM (.020)	
55	179-309	1	SHIM (.020)	
56	300-2017	1	SPACER	
57	300-2536	2	LIFT EYE	
58	150-1431	1	SEAL, SINGLE LIP	
59	300-2393	1	FLANGE	
60	160-1078	1	SPEED SENSOR RING - 36T	
61	150-1607	1	PICKUP TUBE (02N-02NF90-1.5")	
62	115-188	1	NIPPLE (02N-4.250")	
63	514-123	1	PICKUP TUBE (02N-02NF90-2")	
64	117-535	1	SHIM	
65	117-536	1	SHIM	
66	117-537	1	SHIM	
67	157-633	1	O-RING (246 D70)	
68	300-1095	1	BEARING RETAINER	
69	126-012	1	TAPERED RACE (4.527")	
70	126-013	1	TAPERED BEARING (2.952")	
71	160-1009	1	PINION	21 TEETH
72	125-306	1	BEARING (TAPERED ROLLER)	
73	125-307	1	BEARING RACE	
74	115-172	1	COLLAR (02NF-02NF)	
75	191-341	1	INNER WATER SWIVEL REPLACEMENT KIT	SEE FOOTNOTE 1
76	166-152	1	ROTATION GEAR BOX PLANETARY	
77	107-982	12	HHCS M10-1.50 X 85MM,10.9 ZP	
78	157-084	1	O-RING (159 D70)	
79	106-681	8	SCREW (M16-2.00 X 35MM, SOC)	
80	107-001	6	FLG LK SCREW (M10-1.50 X 25MM)	USE LOCTITE 242 OR 243, TORQUE TO 200 FT-LBS
81	155-800	1	O-RING (045 D70)	
82	105-1353	1	PIPE NIPPLE (3/8" X 4.41")	
83	115-178	1	PLUG (06N, SQ FM)	
84	150-2320	1	COUPLER (3/8-NPT X 1 OD, STR)	

NOT SHOWN:

110-111	1	SIGHT GAUGE (6S)	
155-748	1	O-RING (916 D90)	USED ON 110-111 SIGHT GAUGE
106-866	4	DOWEL PIN (M10 X 30MM)	USED TO SET 329-397 ADAPTER TO 329-437 COVER & 166-633 GEARBOX
105-534	3	DOWEL PIN (.375" X .875")	USED ON 164-040 HOUSING TO SET 166-152 ROTATION GEAR BOX

FOOTNOTES:

- INCLUDES 107-803 PIN .125 X .25 IN CASE NEW ONE IS NEEDED TO BE USED ON 160-1040 INNER SHAFT TO SET REF #76 INNER WATER SWIVEL REPLACEMENT KIT. 191-257 SEAL REPAIR KIT (157-469) REPLACEMENT O-RING KIT IS NOT INCLUDED.
- USE KIT 190-1386 GEARBOX NUT, INCLUDES 255-1006 MOLLY PASTE (SINGLE APPLICATION)

NOTE:

THRUST DRIVE

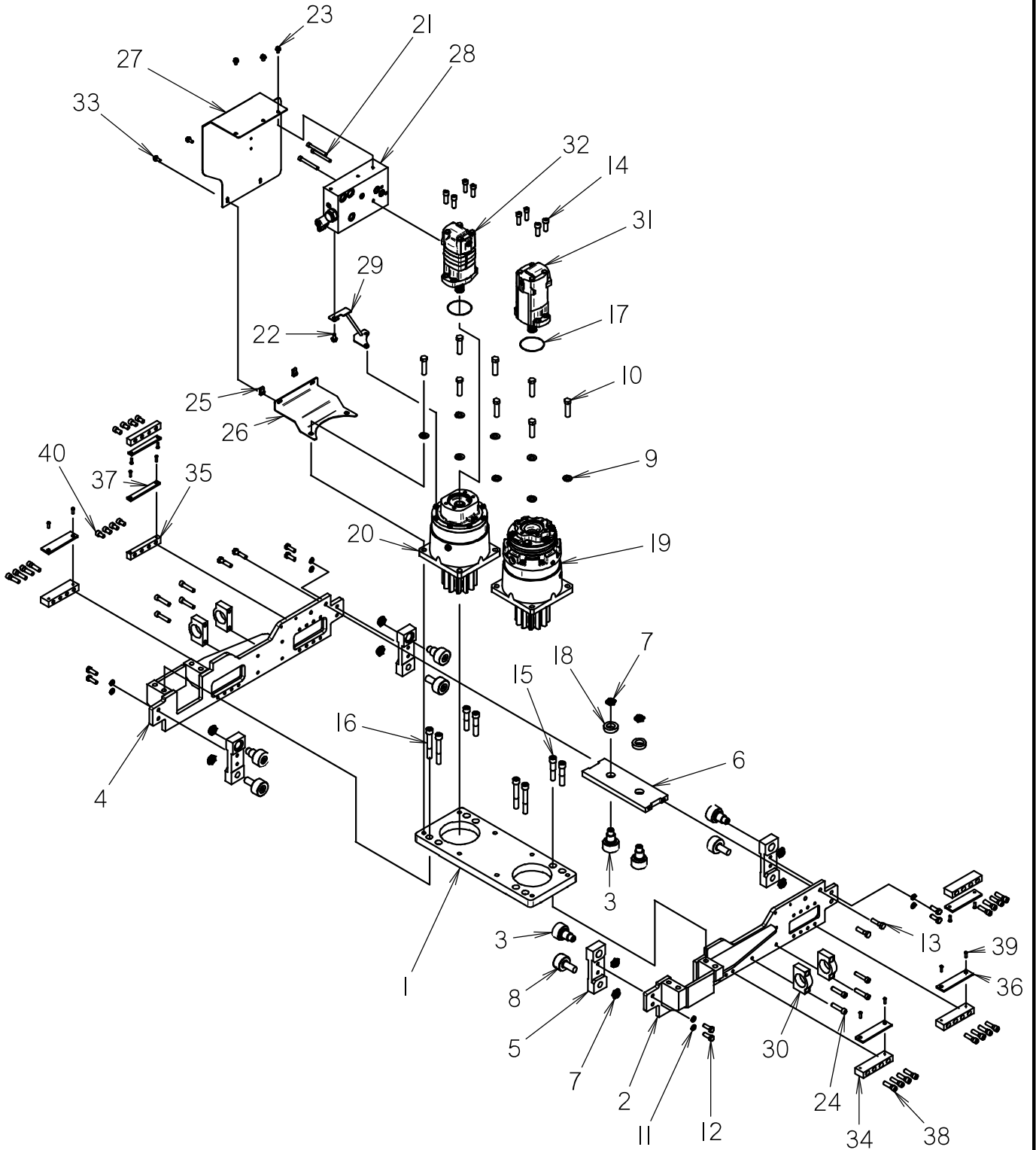

THRUST DRIVE

REF NO.	PART NUMBER	QTY	DESCRIPTION	REMARKS
1	300-1023	1	PLANETARY MOUNT PLATE	
2	300-2665	1	LEFT SIDE DRIVE PLATE	
3	140-1052	6	ROLLER	
4	300-2666	1	RIGHT SIDE DRIVE PLATE	
5	300-2706	4	ROLLER MOUNT	
6	329-800	1	REAR ROLLER MOUNT	
7	107-214	10	LOCKNUT (7/8-14 UNF, NYLON)	
8	140-1041	4	ROLLER	
9	106-398	8	WASHER (M16, HARDENED)	
10	107-598	8	SCREW (M16 X 60MM, I0.9)	USE LOCTITE 242 OR EQUIVALENT, TORQUE TO 200 FT-LBS
11	106-030	8	LOCK WASHER (M12)	
12	107-206	8	HHCS M12-1.75 X 35MM, I0.9 ZP	USE LOCTITE 242 OR EQUIVALENT, TORQUE TO 80 FT-LBS
13	107-748	4	SCREW (M12-1.75 X 50MM, I0.9)	USE LOCTITE 242 OR EQUIVALENT, TORQUE TO 80 FT-LBS
14	106-204	8	BOLT (1/2 - NC X 1.50", SOC)	USE LOCTITE 242 OR EQUIVALENT, TORQUE TO 130 FT-LBS
15	106-785	4	SCREW (M16-2.00 X 80MM, SOC)	USE LOCTITE 242 OR EQUIVALENT, TORQUE TO 240 FT-LBS
16	105-1107	4	SCREW (M16-2.00 X 110MM, SOC)	USE LOCTITE 242 OR EQUIVALENT, TORQUE TO 240 FT-LBS
17	157-099	2	O-RING (042 D70)	
18	300-3103	2	SPACER	
19	160-1074	1	THRUST DRIVE GEARBOX W/BRAKE	USE 42 oz OF 90W
20	160-1030	1	THRUST DRIVE GEARBOX	USE 16 oz OF 90W
21	105-1092	3	BOLT (3/8-NC X 3 1/4", SOC, GD8)	USE LOCTITE 242 OR EQUIVALENT, TORQUE TO 40 FT-LBS
22	105-825	1	FLG LK BOLT (3/8-NC X 3/4)	
23	501-325	3	FLG LK BOLT (5/16-NC X 5/8")	
24	107-602	8	SCREW (M12-1.75 X 55MM, SOC)	USE LOCTITE 242 OR EQUIVALENT, TORQUE TO 80 FT-LBS
25	106-551	2	CLIP NUT (M8-1.25)	
26	300-2396	1	COVER MOUNT	
27	300-2395	1	COVER	
28	152-178	1	MANIFOLD, 2 SPEED THRUST	SEE NOTE 1 & 2 FOR SERVICE PARTS
29	300-3417	1	MANIFOLD SUPPORT	
30	300-4791	4	SPRING STOP	USE LOCTITE 242 OR EQUIVALENT ON MOUNTING HARDWARE
31	158-270	1	HYDRAULIC MOTOR	SEAL KIT 500-1269
32	150-1244	1	HYDRAULIC MOTOR	SEAL KIT 500-1269; SEE NOTE 1
33	106-991	2	FLG LK SCREW (M8-1.25 X 20MM)	
34	300-3875	4	WEAR BAR MOUNT	
35	300-3884	2	WEAR BAR MOUNT	
36	309-666	4	WEAR STRIP	
37	300-3885	2	WEAR STRIP	
38	106-707	16	SCREW (M12-1.75 X 45MM, SOC)	USE LOCTITE 242 OR EQUIVALENT
39	106-640	12	SCREW (M6-1.00 X 20MM, BUT SOC)	
40	107-277	8	SCREW (M12-1.75 X 20MM, SOC)	USE LOCTITE 242 OR EQUIVALENT

NOT SHOWN:

FOOTNOTES:

NOTE:

- 105-1083 1 O-RING; BETWEEN MANIFOLD AND MOTOR
- 150-1328 CARTIDGE VALVE; 150-1329 PILOT VALVE; 500-1432 SOLENOID; 150-1909 SHUTTLE VALVE CARTRIDGE

THRUST DRIVE GEARBOX

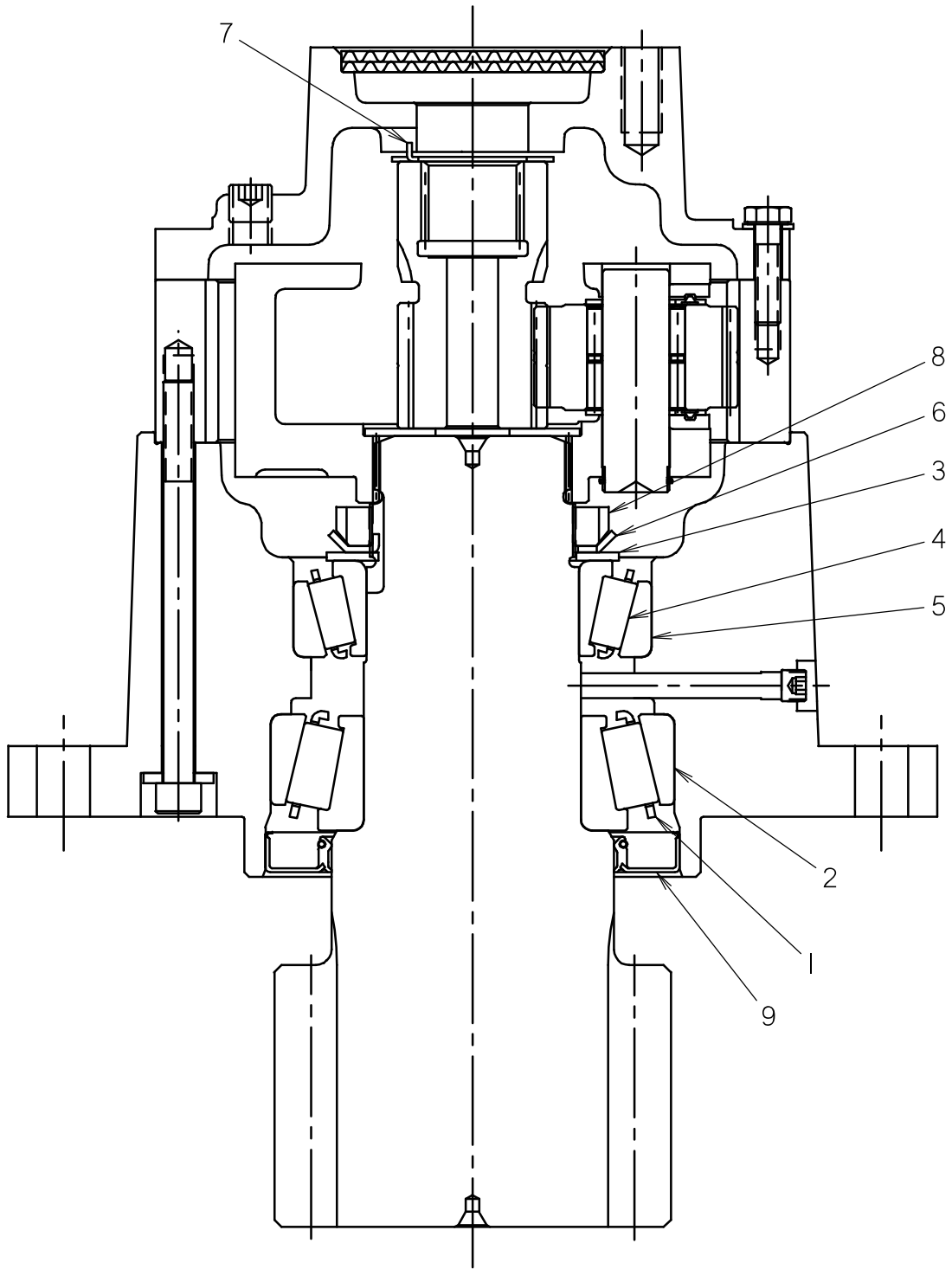

THRUST DRIVE GEARBOX

REF NO.	PART NUMBER	QTY	DESCRIPTION	REMARKS
1.	500-1662	1	BEARING-CONE-6B	
2.	500-1661	1	BEARING-CUP-6B	
3.	500-1666	1	THRUST WASHER-7"	
4.	500-1660	1	BEARING-CONE-7"	
5.	500-1659	1	BEARING-CUP-7"	
6.	500-1657	1	LOCK WASHER-7"	
7.	499-893	1	THRUST WASHER	
8.	500-1663	1	LOCK NUT-7"	
9.	157-521	1	OIL SEAL	SEE FOOTNOTE 1
	500-1674	1	OIL SEAL	SEE FOOTNOTE 2

NOT SHOWN:

500-1696	1	ASSY BRAKE-A2 SERIES; AUSCO
500-1690	1	SPINDLE/SHAFT DRIVE TOOL
500-1690	1	BEARING CONE DRIVER
500-1692	1	BEARINGLOCKNUT TOOL
500-2009	1	O-RING/GASKET KIT
500-2115	1	DISC KIT-2 ROTOR

FOOTNOTES:

1. USED ON 160-1035
2. USED ON 160-1030 & 160-1074

NOTE:

PIPE GUIDE

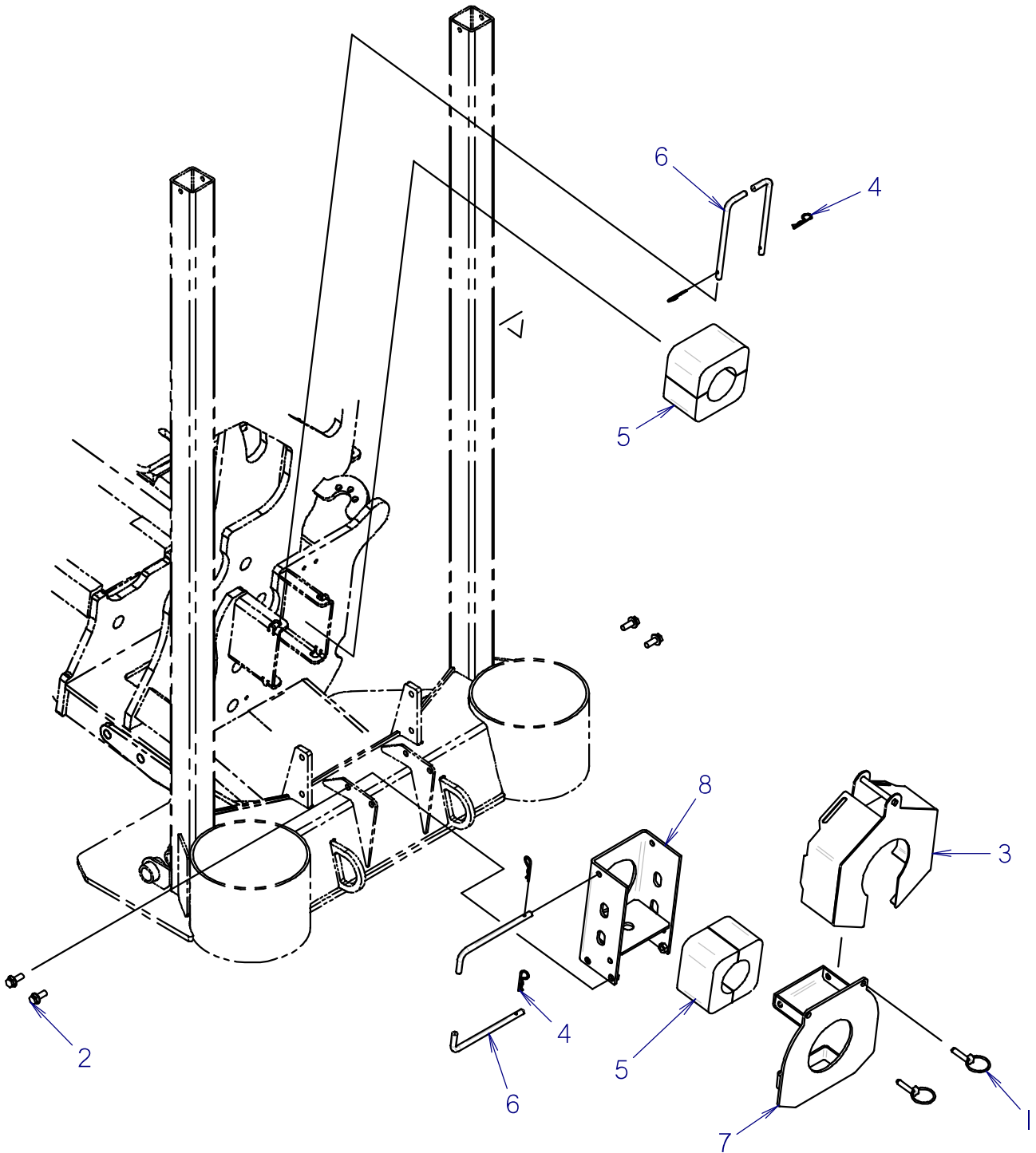

PIPE GUIDE

REF NO.	PART NUMBER	QTY	DESCRIPTION	REMARKS
1	110-228	2	LYNCH PIN (7/16" X 2")	
2	106-469	4	FLG SCREW (M12-1.75 X 30MM)	
3	300-3615	1	WIPER MOUNT	
4	110-033	4	HAIR CLIP PIN (1/8" X 1/2")	
5	362-1076	4	PIPE GUIDE	
6	300-1091	4	PIN	
7	300-3609	1	GUIDE MOUNT CAP	
8	300-3579	1	GUIDE MOUNT	

NOT SHOWN:

149-973 1 SPLIT ROD WIPER 1.75" ID

INCL IN SHIP KIT

FOOTNOTES:

NOTE:

ROTATING WRENCH

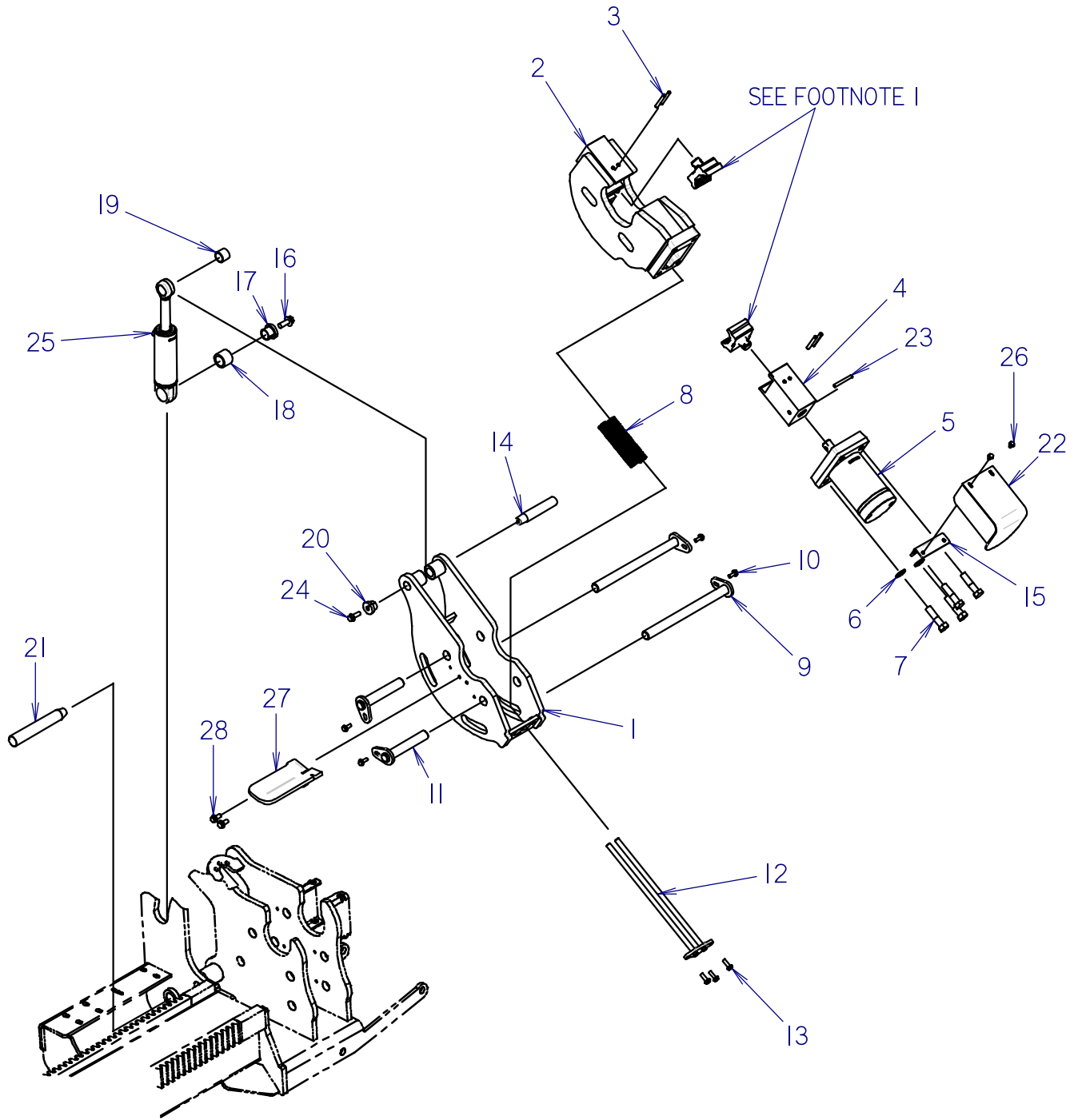

ROTATING WRENCH

REF NO.	PART NUMBER	QTY	DESCRIPTION	REMARKS
1	329-201	1	ROTATING WRENCH	
2	329-203	1	REAR WRENCH	
3	107-777	4	SPIRAL SPRING PIN .375 X 3.000	
4	329-204	1	JAW BLOCK	
5	152-140	1	CYLINDER ASSEMBLY	
6	106-399	2	WASHER (M20, HARDENED)	
7	107-127	4	SCREW (M20-2.50 X 80MM, 10.9)	USE LOCTITE 242 OR EQUIVALENT, TORQUE TO 400 FT-LBS
8	105-1144	2	COMPRESSION SPRING	
9	177-252	2	PIN	
10	107-001	4	FLG LK SCREW (M10-1.50 X 25MM)	
11	177-253	2	PIN	
12	300-2947	1	CENTER PIN WELDMENT	
13	106-383	3	FLG LK SCREW (M10-1.50 X 30MM)	
14	183-923	1	TAPERED PIN (31.7MM X 174MM)	
15	300-2305	1	COVER MOUNT	
16	106-470	1	FLG SCREW (M16-2.0 X 40MM)	
17	181-974	1	TAPERED INSERT (1.5")	
18	125-772	1	COMPOSITION BUSHING (1.5")	
19	125-771	1	COMPOSITION BUSHING (1.25")	
20	181-982	1	TAPERED INSERT (1.25")	
21	183-879	1	TAPERED PIN (1.500" X 10.150"	
22	300-2725	1	COVER	
23	106-984	1	DOWEL PIN .375" X 3.25"	
24	106-632	1	FLG LK SCR (M12-1.75X35MM,SER)	
25	149-797	1	CYL (2.5 X 1.25 X 5.0)	
26	106-380	2	FLG LK SCREW (M8-1.25 X 16MM)	
27	300-4597	1	PIPE GUIDE	
28	106-806	2	FLG LK SCREW (M12-1.75 X 25MM)	USE LOCTITE 242 OR EQUIVALENT, TORQUE TO 55 FT-LBS

NOT SHOWN:

FOOTNOTES:

- I. FOR "JT" JAW USE 375-1003; "AT" JAW USE 375-1005

NOTE:

STATIONARY WRENCH

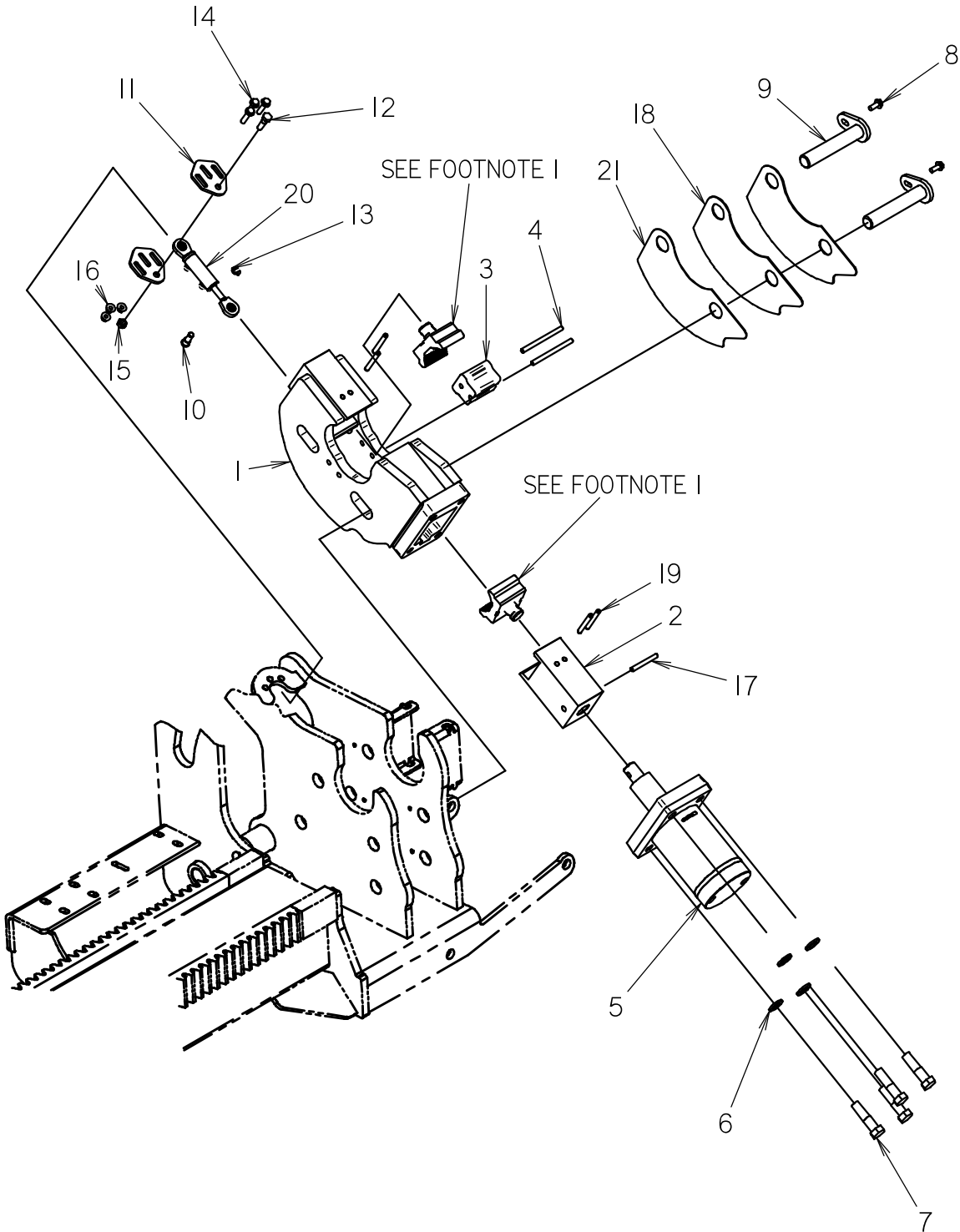

STATIONARY WRENCH

REF NO.	PART NUMBER	QTY	DESCRIPTION	REMARKS
1	329-202	1	FRONT WRENCH	
2	329-204	1	JAW BLOCK	
3	177-268	1	PIPE SUPPORT	
4	177-269	2	PIN	
5	152-140	1	CYL. (4.50" X 2.25" X 3.00")	
6	106-399	4	WASHER (M20, HARDENED)	
7	107-127	4	SCREW (M20-2.50 X 80MM, 10.9)	USE LOCTITE 242 OR EQUIVALENT; TORQUE TO 400 FT-LBS
8	107-001	2	FLG LK SCREW (M10-1.50 X 25MM)	
9	177-253	2	PIN	
10	105-1246	1	PIN	
11	323-061	2	MOUNT PLATE	
12	106-477	1	SCREW (M12-1.75 X 45MM, 10.9)	
13	115-506	1	KLIP RING (.500")	
14	106-995	3	FLG LK SCREW (M10-1.50 X 45MM)	
15	106-685	1	LOCKNUT (M12-1.75, PRV TRQ, 10.9)	
16	106-387	3	FLG LOCKNUT (M10-1.50)	
17	106-984	1	DOWEL PIN .375" X 3.25"	
18	300-2089	2	SHIM	
19	107-777	4	SPIRAL SPRING PIN .375 X 3.000	
20	150-1614	1	CYLINDER (1.0 X .50 X 1.65)	
21	301-1698	1	SHIM (THIN)	

NOT SHOWN:

FOOTNOTES:

1. FOR "JT" JAW USE 375-1003; "AT" JAW USE 375-1005

NOTE:

JAW INSERTS

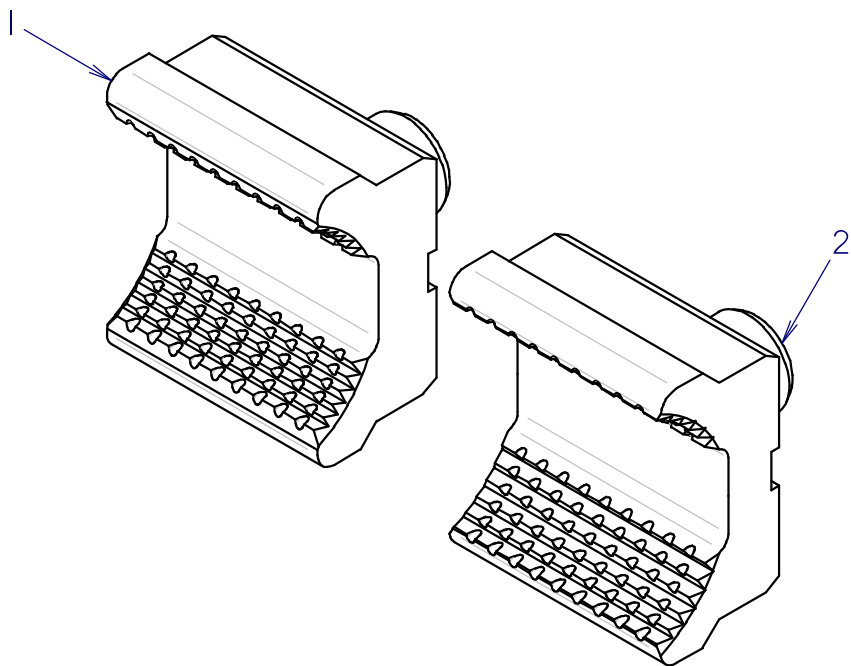

JAW INSERTS

REF NO.	PART NUMBER	QTY	DESCRIPTION	REMARKS
1	375-1003	1	JAW INSERT (JT)	
2	375-1005	1	JAW INSERT (AT)	

NOT SHOWN:

FOOTNOTES:

NOTE:

FUEL TANK ASSEMBLY

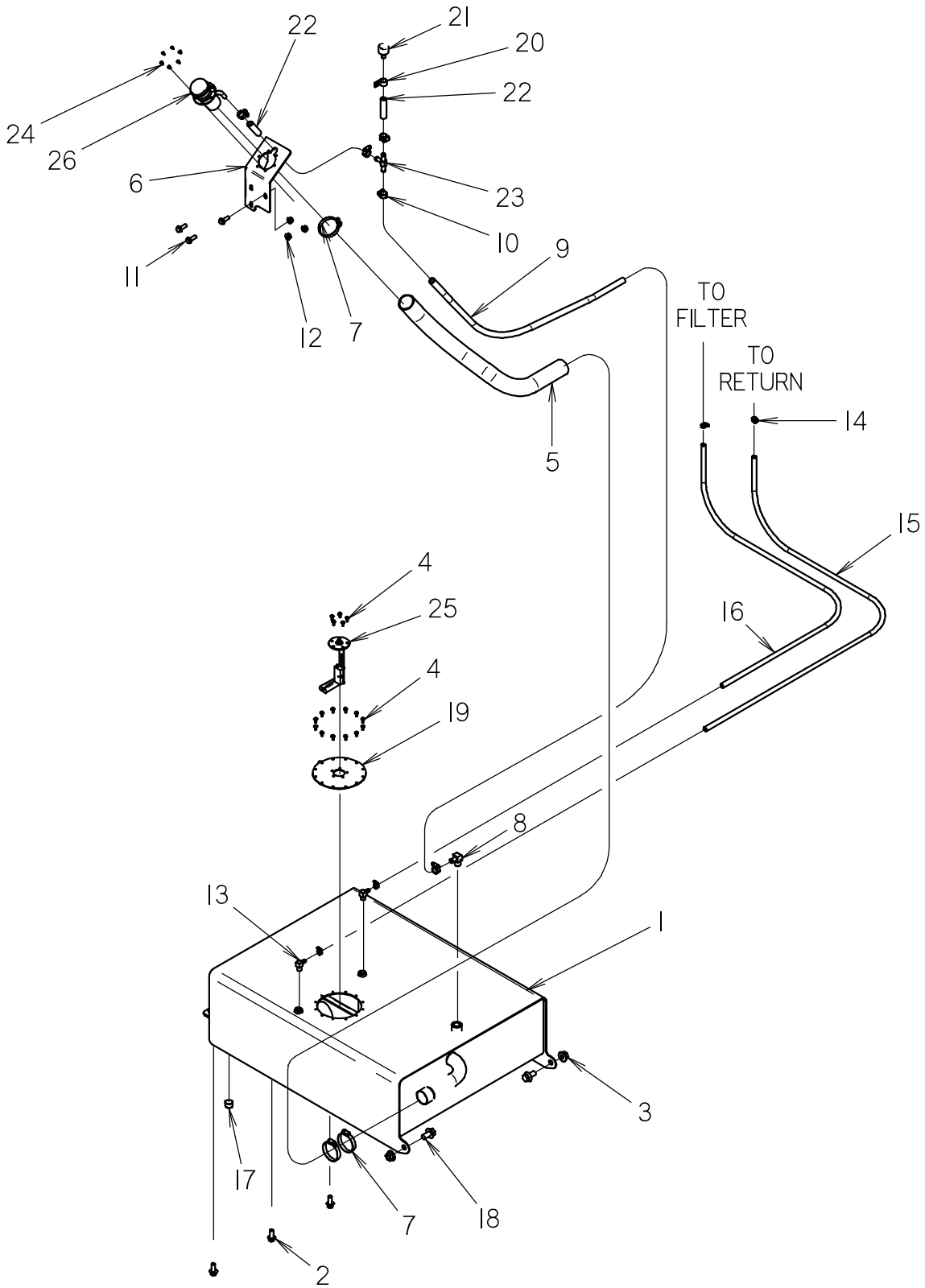

FUEL TANK ASSEMBLY

REF NO.	PART NUMBER	QTY	DESCRIPTION	REMARKS
1	300-8012	1	FUEL TANK	
2	107-010	3	FLG LK SCREW (M12-1.75 X 30MM)	
3	106-355	2	FLG NUT (M16-2.00, 10.9)	
4	105-214	17	FLG SCREW (#10-24 X .5")	
5	118-290	1	FUEL HOSE	
6	300-1060	1	FILL BRACKET	
7	110-134	3	WORM CLAMP (2.062" TO 2.750")	
8	156-108	1	S/O COUPLER (08N-08H90)	
9	116-322	30	BULK HOSE (1/2",SOLD PER 1")	USE 1 @ 30"
10	110-217	5	WORM CLAMP (7/16" TO 1")	
11	106-383	3	FLG LK SCREW (M10-1.50 X 30MM)	
12	106-387	3	FLG LOCKNUT (M10-1.50)	
13	153-871	2	S/O COUPLER (06N-06H90, BRS)	
14	110-249	4	WORM CLAMP (1/4" TO 5/8")	
15	116-881	85	BULK HOSE (3/8", SOLD PER FT)	
16	116-881	75	BULK HOSE (3/8", SOLD PER FT)	
17	115-152	1	PLUG (12N, SQ FM)	
18	106-471	2	FLG SCREW (M16-2.00 X 30MM)	
19	300-2199	1	COVER PLATE	USE LOCTITE AVIATION SEALANT OR EQUIVALENT
20	110-373	1	BOLT-ON CLAMP (13/16")	
21	111-021	1	BREATHER CAP (TANK)	
22	116-322	16	BULK HOSE (1/2",SOLD PER 1")	USE 1 @ 6", USE 1 @ 10"
23	156-729	1	S/O TEE (08H-08H-08H)	
24	110-560	6	POP RIVET (3/16" X 1/2", ALUM)	
25	217-568	1	FUEL SENDER	
26	364-661	1	FILLER NECK	

NOT SHOWN:

FOOTNOTES:

NOTE:

TRACK GROUP

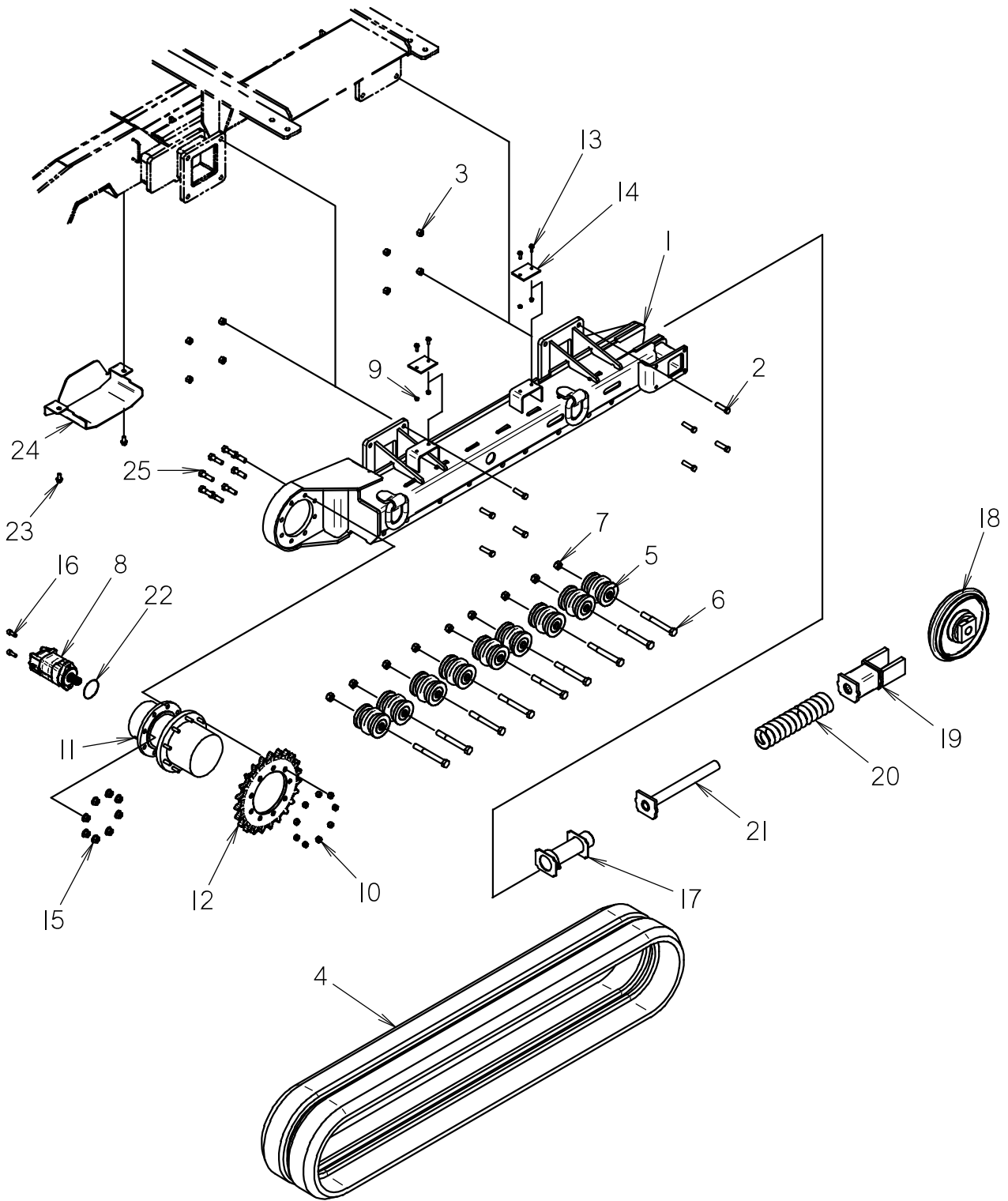

TRACK GROUP

REF NO.	PART NUMBER	QTY	DESCRIPTION	REMARKS
1	327-942	1	RIGHT TRACK FRAME	SEE NOT SHOWN FOR LEFT TRACK FRAME
2	107-598	8	SCREW (M16 X 60MM, I0.9)	
3	106-545	8	LOCKNUT (M16-2.0,PRV TRQ,I0.9)	
4	308-746	1	RUBBER TRACK (320MM,98P,52.5MM)	
5	129-010	9	IDLER ROLLER PARTS	
6	106-727	9	SCREW (M20-2.50 X 180MM, I0.9)	
7	106-665	9	LOCKNUT (M20-2.50, I0.9)	
8	157-930	1	HYDRAULIC MOTOR	RIGHT SIDE MOTOR, SEE FOOTNOTE 1
9	106-386	4	FLG LOCKNUT (M8-1.25)	
10	105-114	9	LUG NUT (1/2-NF)	USE LOCTITE 242, TORQUE TO 100 FT-LBS
11	166-614	1	PLANETARY GEARBOX	SEE FOOTNOTE 2 FOR SERVICE PARTS
12	141-586	1	23 TOOTH TRACK SPROCKET	
13	106-381	4	FLG LK SCREW (M8-1.25 X 25MM)	
14	356-788	2	SLIDE PAD	
15	106-355	8	FLG NUT (M16-2.00, I0.9)	
16	105-282	2	BOLT (1/2 - NC X 1.25", SOC)	USE LOCTITE 277, TORQUE TO 130 FT-LBS
17	151-181	1	GREASE CYLINDER ASSEMBLY	
18	170-339	1	IDLER ROLLER ASSEMBLY	
19	343-551	1	YOKE	
20	117-112	1	SPRING	
21	343-550	1	TUBE	
22	157-099	1	O-RING (O42 D70)	
23	106-806	2	FLG LK SCREW (M12-1.75 X 25MM)	
24	300-1785	1	MOTOR COVER	
25	106-074	8	SCREW (M16-2.00 X 60MM)	

NOT SHOWN:

327-941 1 LEFT TRACK FRAME
158-929 1 HYDRAULIC MOTOR

LEFT SIDE MOTOR, SEE FOOTNOTE 1, 3

FOOTNOTES:

- 500-658 SEAL REPAIR KIT,
- SERVICE PARTS INCLUDE: 500-1919 INPUT SHAFT; 500-658 SEAL KIT; 105-1354 BOLT; 500-2009 O-RING/GASKET KIT, 500-2118 DISENGAGE SPRING; 500-2119 DISENGAGE WASHER
- 500-1653 SHAFT & BEARING KIT

NOTE:

IDLER ROLLER PARTS

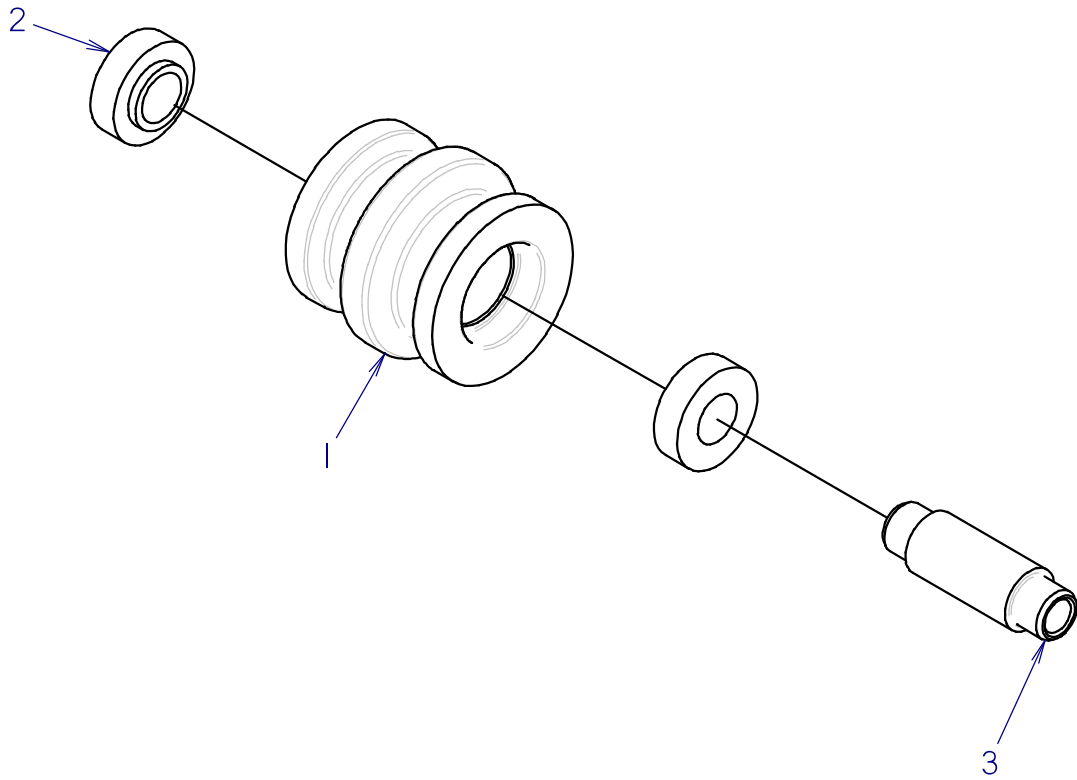

IDLER ROLLER PARTS

REF NO.	PART NUMBER	QTY	DESCRIPTION	REMARKS
1	309-423	1	ROLLER SHELL	
2	125-135	2	BALL BEARING (2.362")	
3	343-825	1	ROLLER SHAFT	

NOT SHOWN:

FOOTNOTES:

NOTE:

IDLER ASSEMBLY

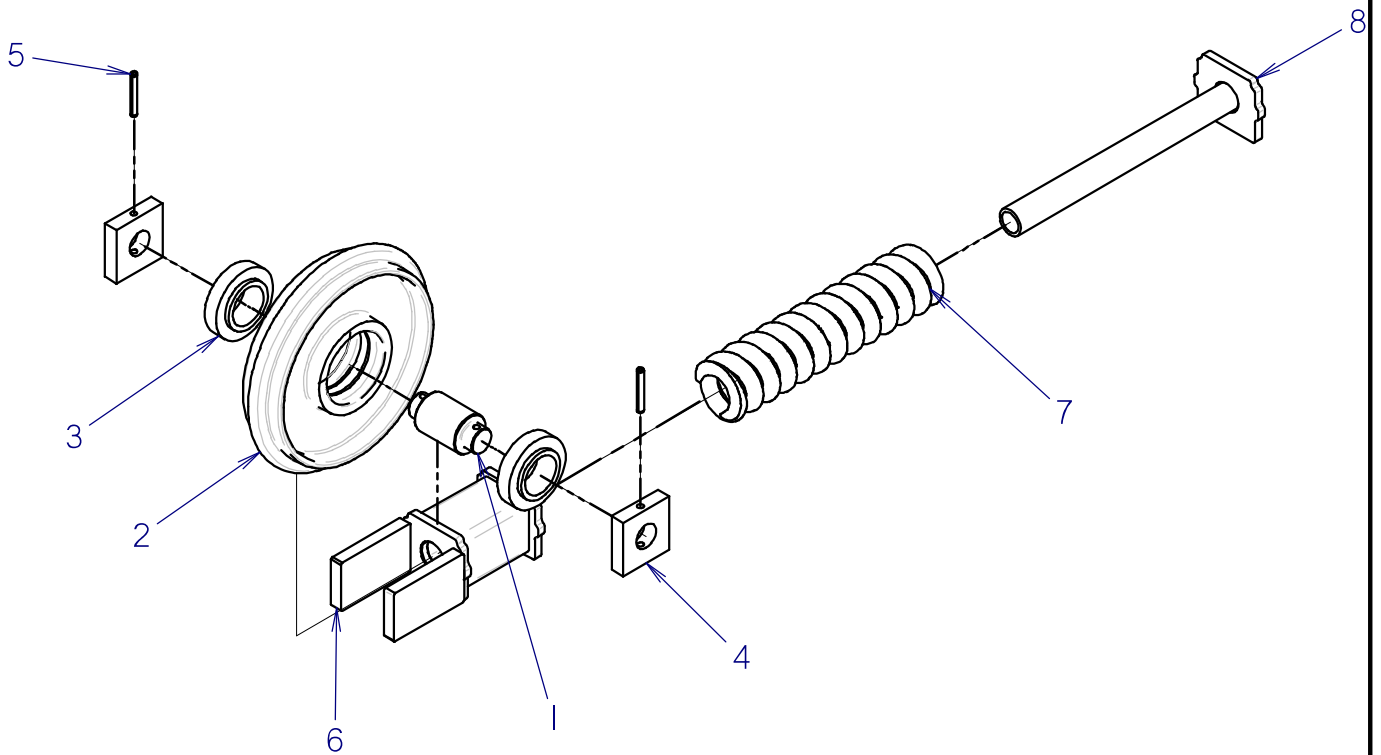

IDLER ASSEMBLY

REF NO.	PART NUMBER	QTY	DESCRIPTION	REMARKS
1	343-836	1	IDLER SHAFT	
2	343-837	1	IDLER	
3	125-134	2	BALL BEARING (2.362")	
4	343-835	2	PUSH BLOCK	
5	105-561	2	ROLL PIN (3/8" X 2-3/4")	
6	343-551	1	YOKE	
7	117-112	1	SPRING	
8	343-550	1	TUBE	

NOT SHOWN:

FOOTNOTES:

NOTE:

GREASE CYLINDER

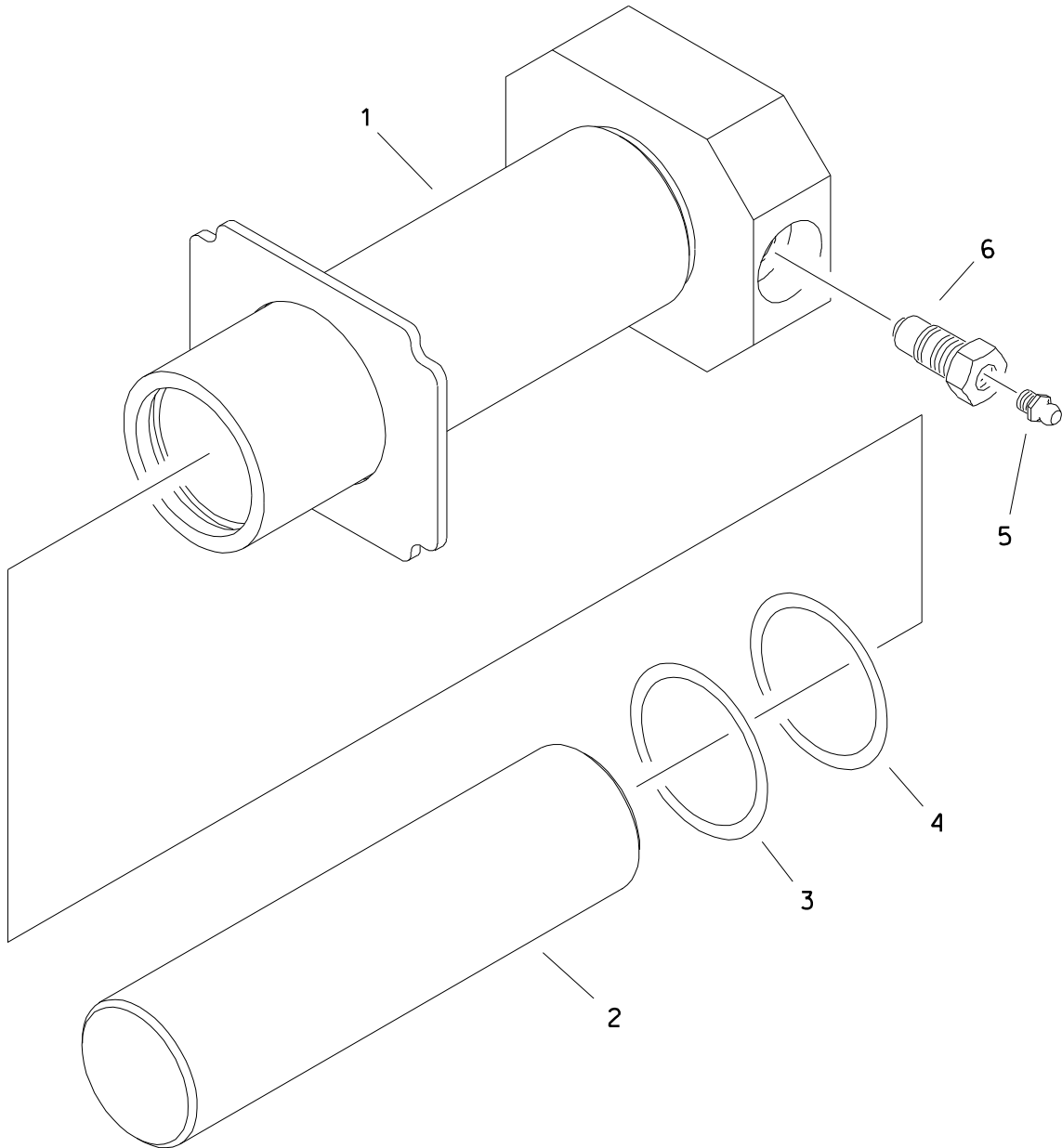

GREASE CYLINDER

REF NO.	PART NUMBER	QTY	DESCRIPTION	REMARKS
	151-181		GREASE CYLINDER	INCL REF NO'S 1,2,3,4, & 6.
1.	343-552	1	GREASE CYLINDER	
2.	350-804	1	CYLINDER ROD	
3.	157-021	1	BACKUP RING (228 D90)	
4.	500-031	1	O-RING (228 D90)	
5.	115-019	1	ZERK (Q2N)	
6.	159-093	1	RELIEF VALVE (5/8 - NF, Q2N)	

FOOTNOTES

HOSE TRACK

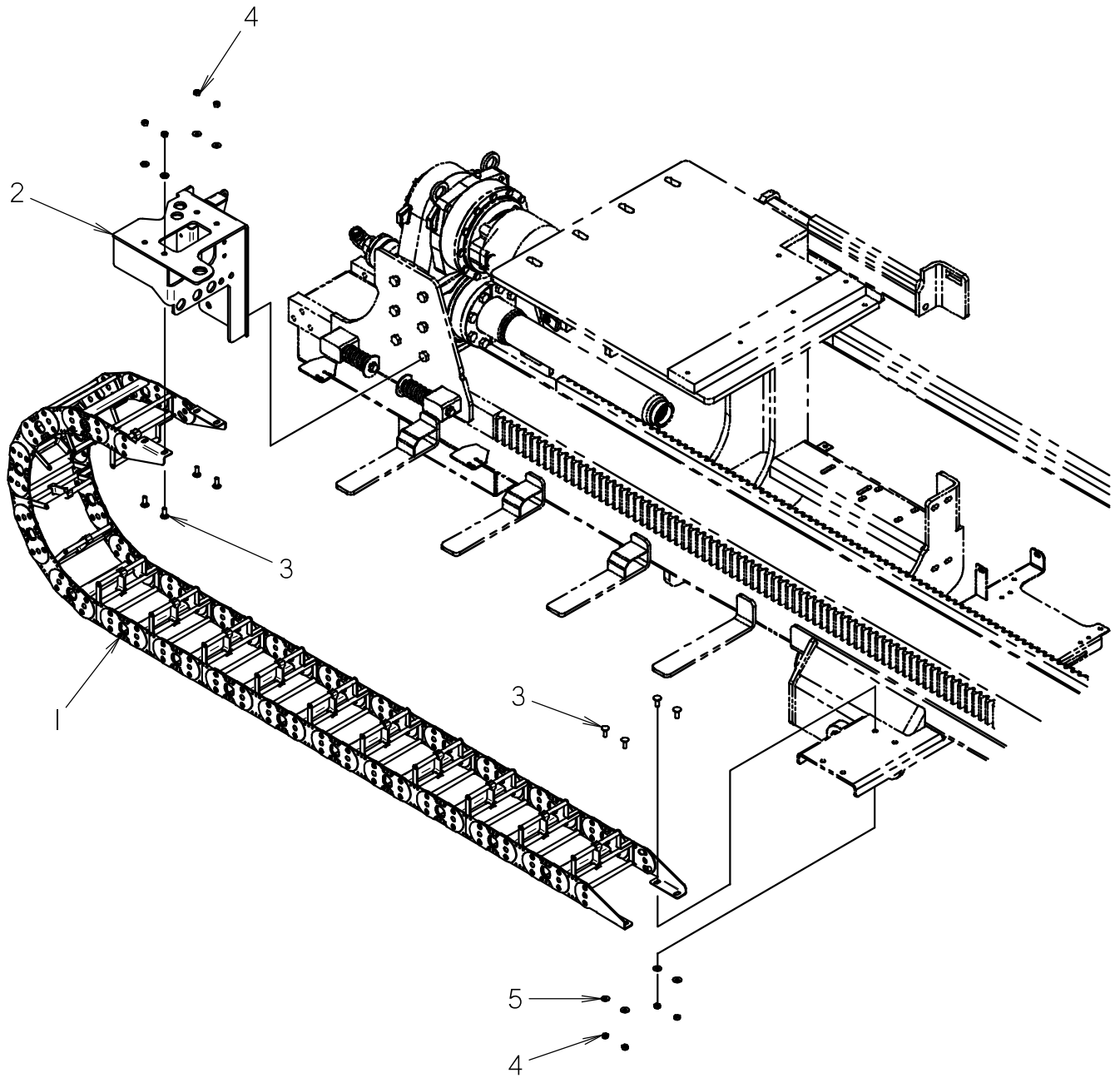

HOSE TRACK

REF NO.	PART NUMBER	QTY	DESCRIPTION	REMARKS
1	118-452	1	HOSE TRACK	SEE FOOTNOTE 1 FOR SERVICE PARTS
2	329-540	1	HOSE TRACK MOUNT	
3	105-600	8	CARRIAGE BOLT (3/8-NC X 1")	
4	105-047	8	LOCKNUT (3/8-NC)	
5	105-117	8	WASHER (5/16")	

NOT SHOWN:

FOOTNOTES:

500-1195 HOSE TRACK 4-LINK REPAIR KIT. CONTAINS: 2X INNER LINKS, 4X COMMON LINKS, 2X LEFT WINDOW EXTENDERS, 2X RIGHT WINDOW EXTENDERS, 16X LINK PINS, 16X SNAP RINGS, 2X SEPARATOR BARS, 4X EXTENDER RIVETS, 2X SI BARS, 2X LONG E-Z OUTS, 2X SHORT E-Z OUTS, 4X POLY BARS, FLAT BARS, 12X 10-24 SCREWS.

500-1196 LONG E-Z OUT, 500-1197 SHORT E-Z OUT, 500-2001 SEPARATOR, 500-2000 POLY ROLLER 2.97" PARTS SOLD EACH

NOTE:

STABILIZERS

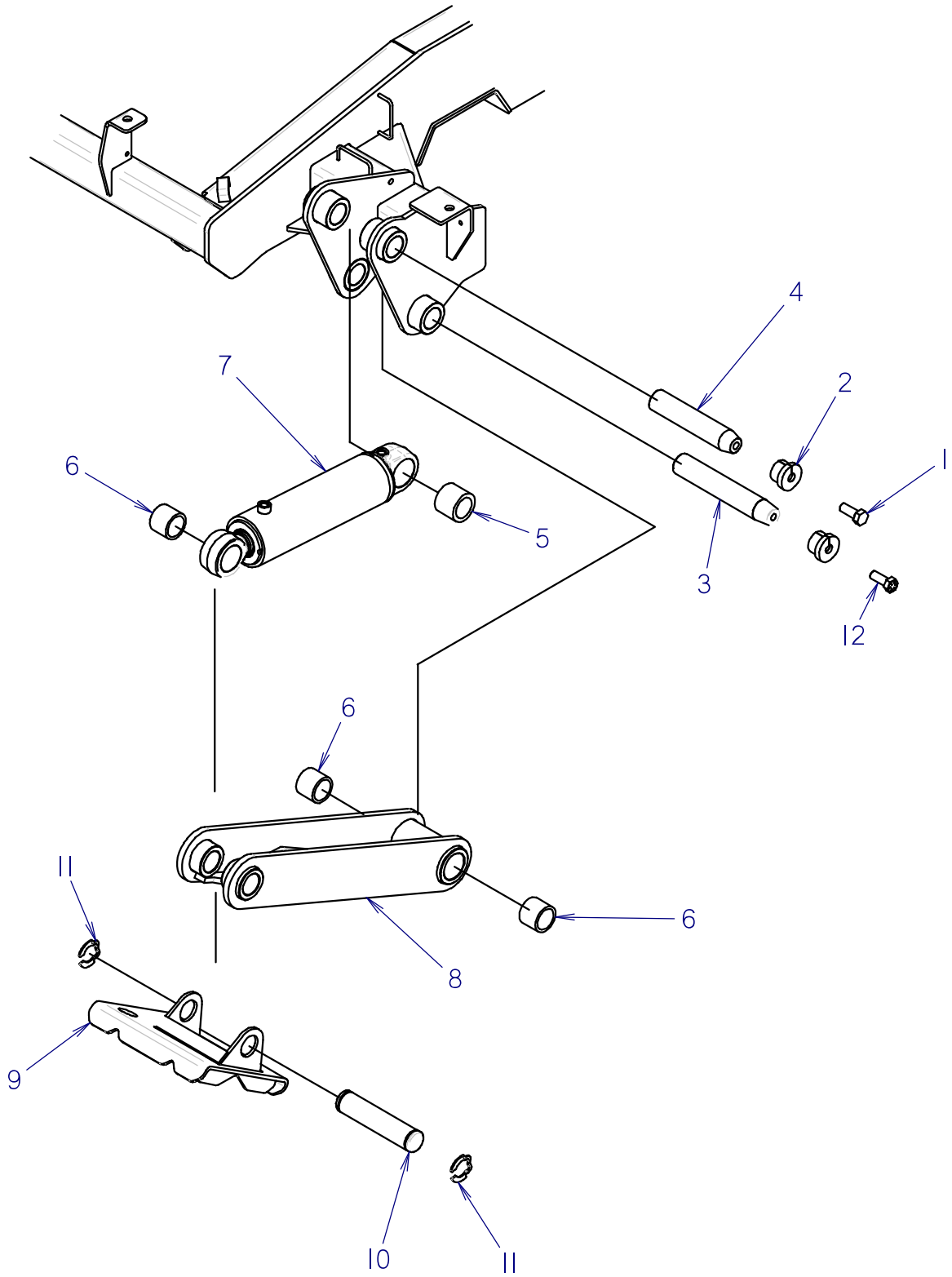

STABILIZERS

REF NO.	PART NUMBER	QTY	DESCRIPTION	REMARKS
1	106-607	1	SCREW (M20-2.50 X 50MM, 10.9)	
2	184-064	2	TAPERED INSERT (2")	
3	179-146	1	"NS" TAPERED PIN (2.0" X 11.5")	
4	300-3148	1	TAPERED PIN (2.000" X 9.810")	
5	125-844	1	COMPOSITION BUSHING (2")	
6	125-754	3	COMPOSITION BUSHING (2")	
7	151-088	1	CYL (4.0 X 2.00 X 12.0)	
8	300-2845	1	STABILIZER ARM	
9	300-2844	1	RIGHT STABILIZER	USE 300-2843 LEFT STABILIZER ON OTHER SIDE
10	300-2841	1	PAD PIN	
11	115-781	2	KLIP RING (2.000")	
12	105-961	1	BOLT (3/4-NC X 2")	

NOT SHOWN:

FOOTNOTES:

NOTE:

STABILIZER CYLINDER LOCKS

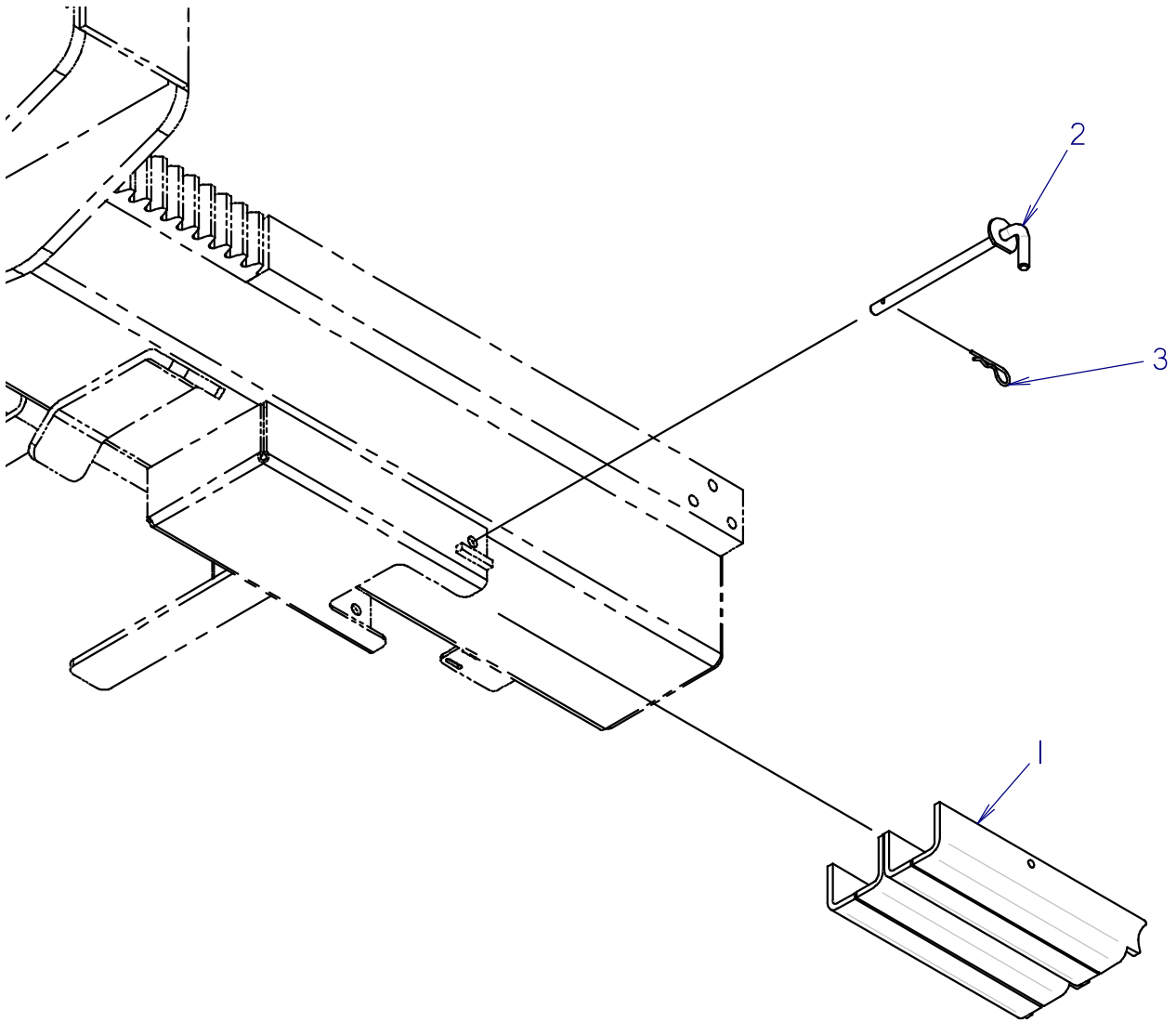

STABILIZER CYLINDER LOCKS

REF NO.	PART NUMBER	QTY	DESCRIPTION	REMARKS
1	300-2301	2	CYLINDER LOCK	
2	300-2486	1	PIN	
3	110-033	1	HAIR CLIP PIN (1/8" X 1/2")	

NOT SHOWN:

FOOTNOTES:

NOTE:

PIVOT

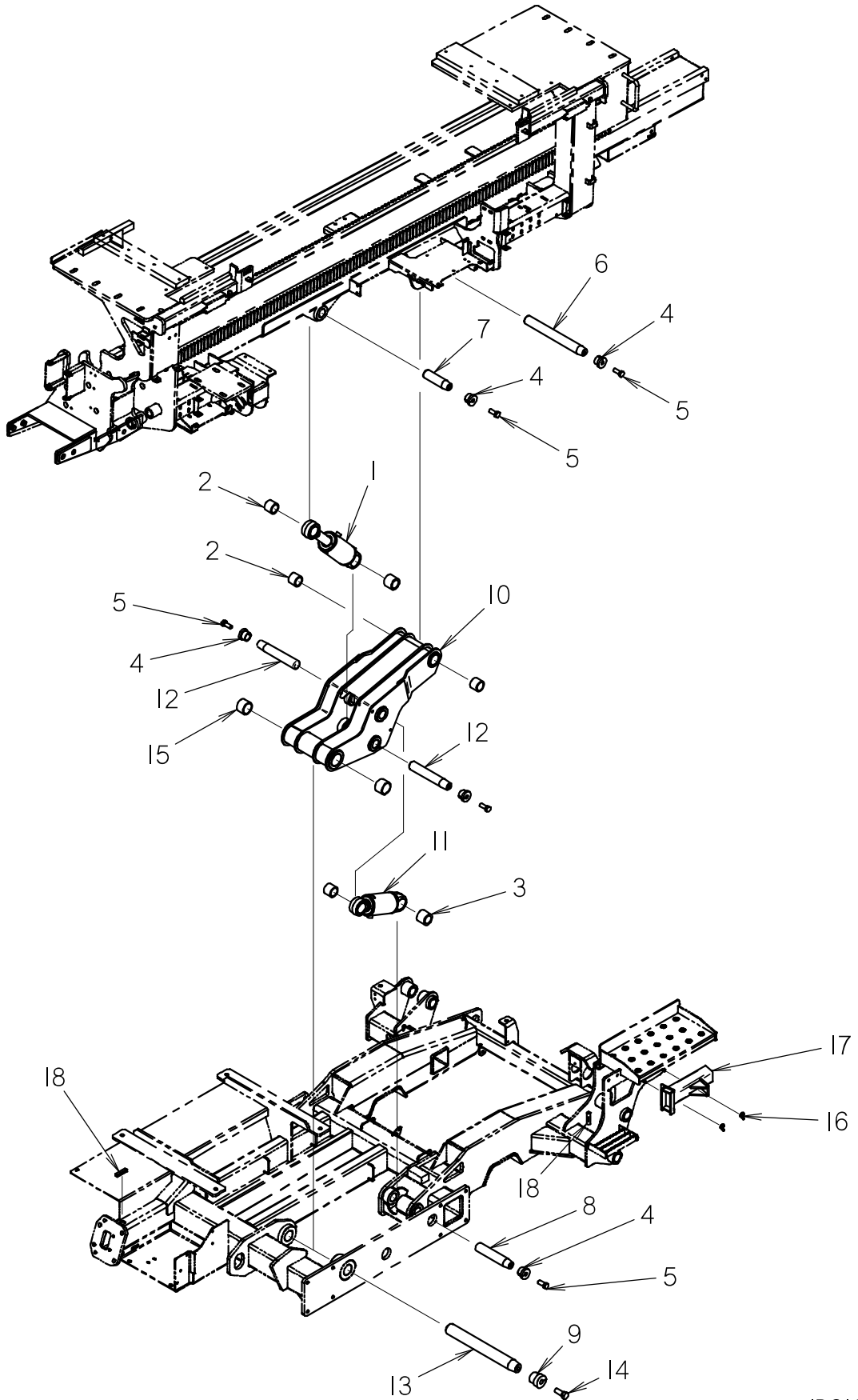

PIVOT

REF NO.	PART NUMBER	QTY	DESCRIPTION	REMARKS
1	150-2047	1	CYL (4.0 X 2.00 X 4.50)	
2	125-754	4	COMPOSITION BUSHING (2")	
3	125-844	2	COMPOSITION BUSHING (2")	
4	184-064	5	TAPERED INSERT (2")	
5	106-607	5	SCREW (M20-2.50 X 50MM, 10.9)	USE LOCTITE 277 OR EQUIVALENT
6	179-177	1	TAPERED PIN (50.8MM X 460MM)	
7	183-919	1	TAPERED PIN (50.8MM X 190MM)	
8	300-1788	1	TAPERED PIN (2.000" X 10.375")	
9	184-575	1	TAPERED INSERT (2.5")	
10	305-874	1	LINK	
11	149-698	1	CYL (4.0 X 2.00 X 4.0)	
12	179-189	2	TAPERED PIN (50.8 X 300)	
13	300-2917	1	TAPERED PIN (2.500" X 21.900")	
14	106-667	1	SCREW (M24-3.00 X 65MM, 10.9)	USE LOCTITE 277 OR EQUIVALENT
15	125-762	2	SPRING BUSHING (2.500")	
16	107-478	2	WING NUT (1/2-NC)	
17	300-6241	1	SUPPORT	
18	116-259	16	BULK EDGE (1/2", SOLD PER FT)	

NOT SHOWN:

110-991 3 BRONZE WASHER (2.531")

FOOTNOTES:

NOTE:

DRILL FRAME PROXIMITY SWITCHES

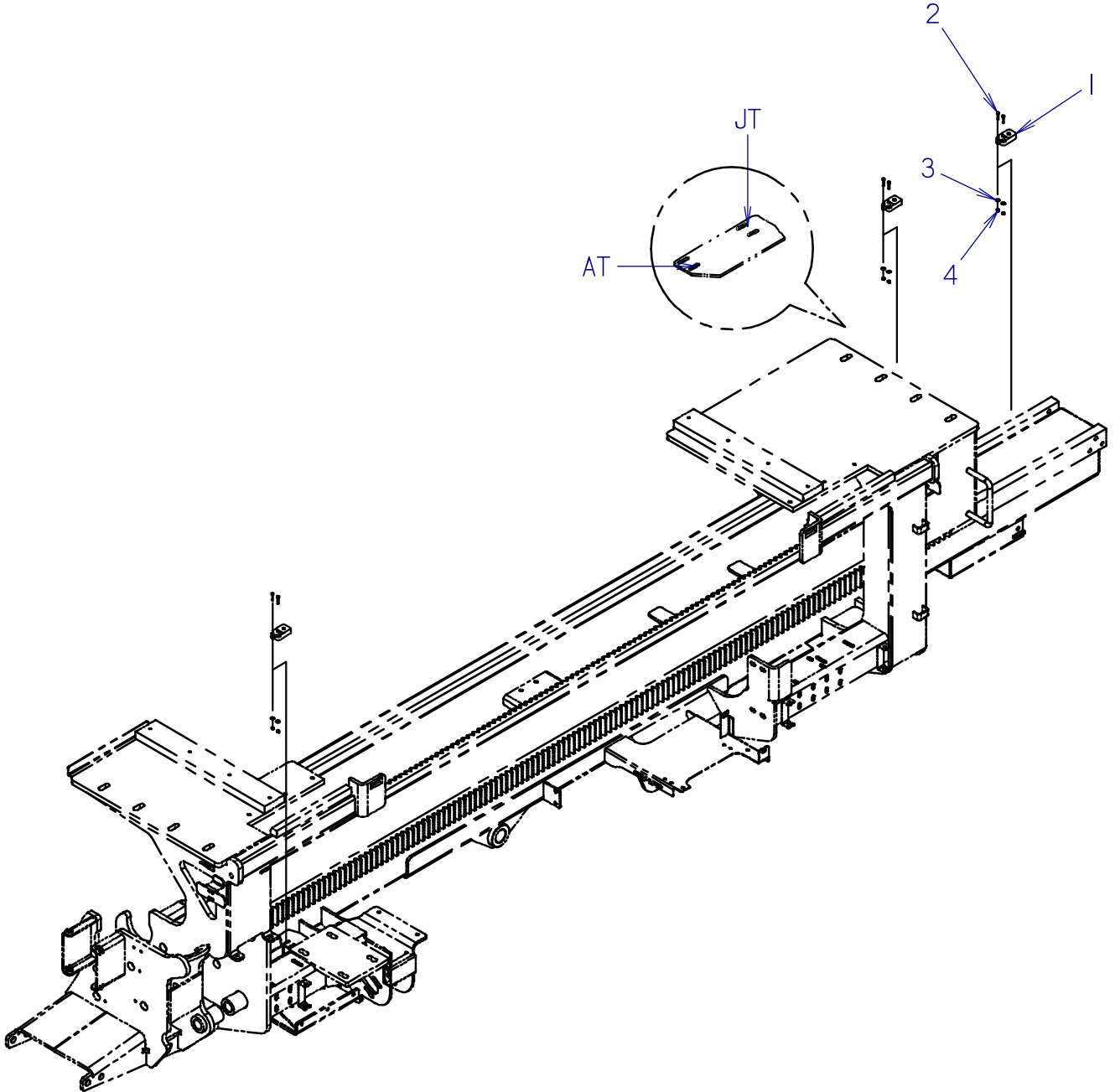

DRILL FRAME PROXIMITY SWITCHES

REF NO.	PART NUMBER	QTY	DESCRIPTION	REMARKS
1	215-1175	3	PROXIMITY SWITCH	
2	106-426	6	SCREW (M5-0.80 X 25MM, SOC)	
3	105-284	6	WASHER (3/16")	
4	106-850	6	LOCKNUT (M5-0.80)	

NOT SHOWN:

- 107-450 AR SHIM (.075")
- 107-451 AR SHIM (1.35")

FOOTNOTES:

NOTE:

PIPE RESTRAINT

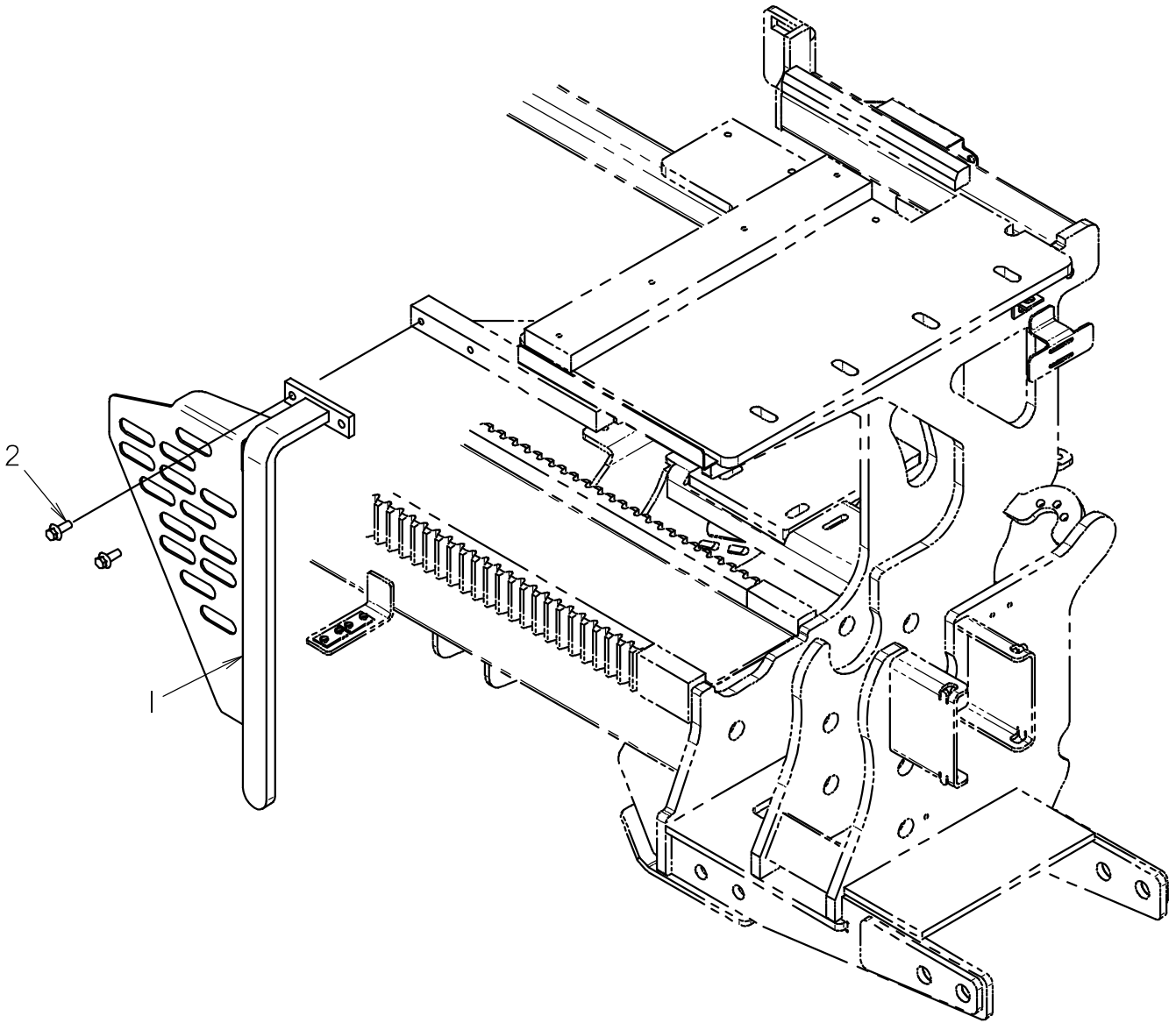

PIPE RESTRAINT

REF NO.	PART NUMBER	QTY	DESCRIPTION	REMARKS
1	301-1188	1	PIPE RESTRAINT	
2	107-010	2	FLG LK SCREW (M12-1.75 X 30MM)	USE LOCTITE 242 OR EQUIVALENT

NOT SHOWN:

FOOTNOTES:

NOTE:

PIPE SENSOR SUB

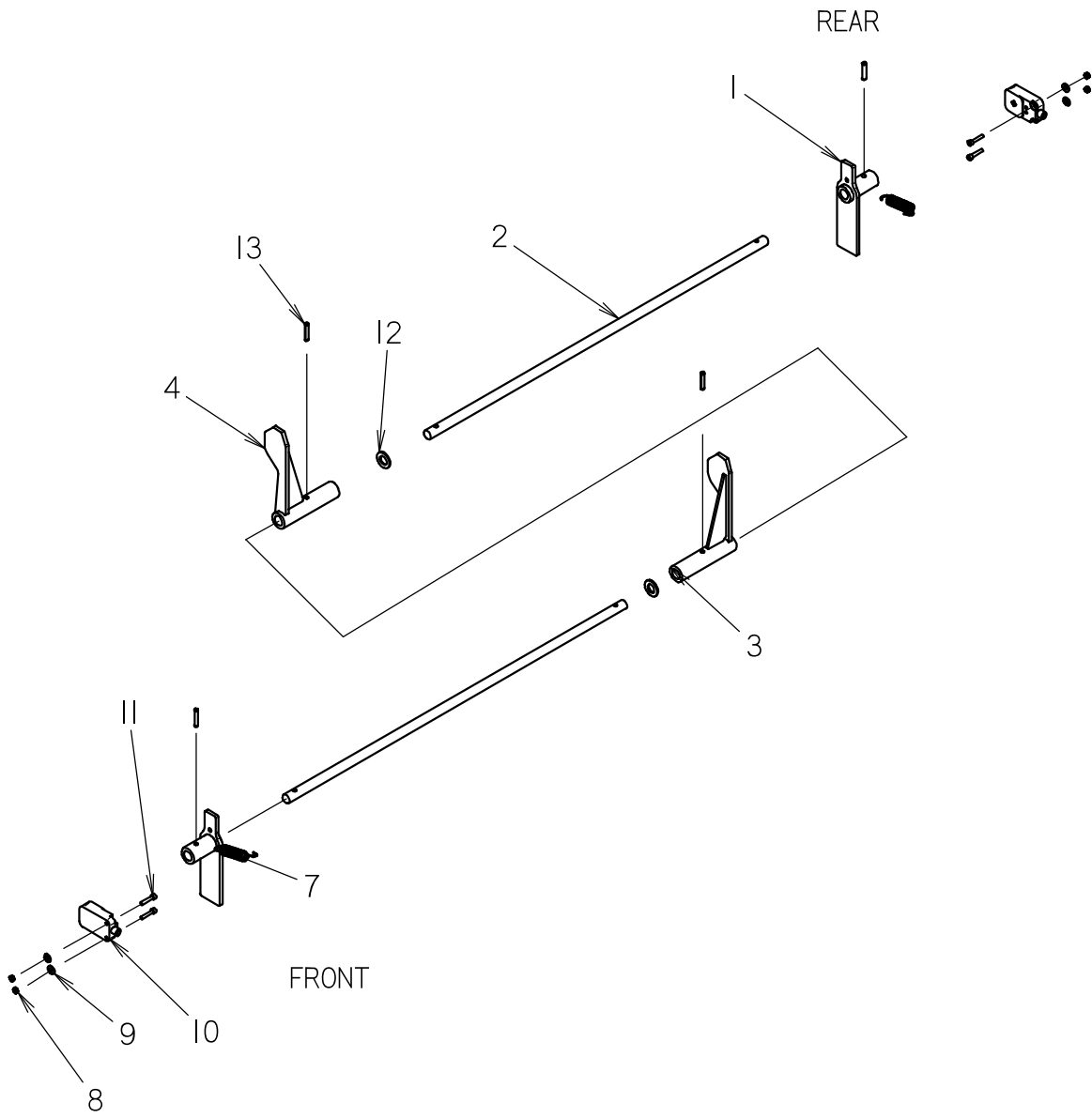

PIPE SENSOR SUB

REF NO.	PART NUMBER	QTY	DESCRIPTION	REMARKS
1	300-3207	2	TARGET ARM	
2	177-280	2	PIVOT BAR	
3	329-789	1	FOLLOWER ARM, FRONT	
4	329-665	1	FOLLOWER ARM, REAR	
7	115-601	2	EXTENSION SPRING (4.062)	
8	106-850	4	LOCKNUT (M5-0.80)	
9	105-284	4	WASHER (3/16")	
10	215-1175	2	PROXIMITY SWITCH	
11	106-426	4	SCREW (M5-0.80 X 25MM, SOC)	
12	126-128	2	THRUST WASHER RACE (.625")	SEE FOOTNOTE I
13	105-513	4	ROLL PIN (1/4" X 1-1/4")	

NOT SHOWN:

107-450 SHIM (.075")
107-451 SHIM (.135")

FOOTNOTES:

I. USE PROX SHIMS AS REQUIRED, SWITCH SHOULD BE MAX. .250" FROM TARGET ARM.

NOTE:

WORK LIGHTS

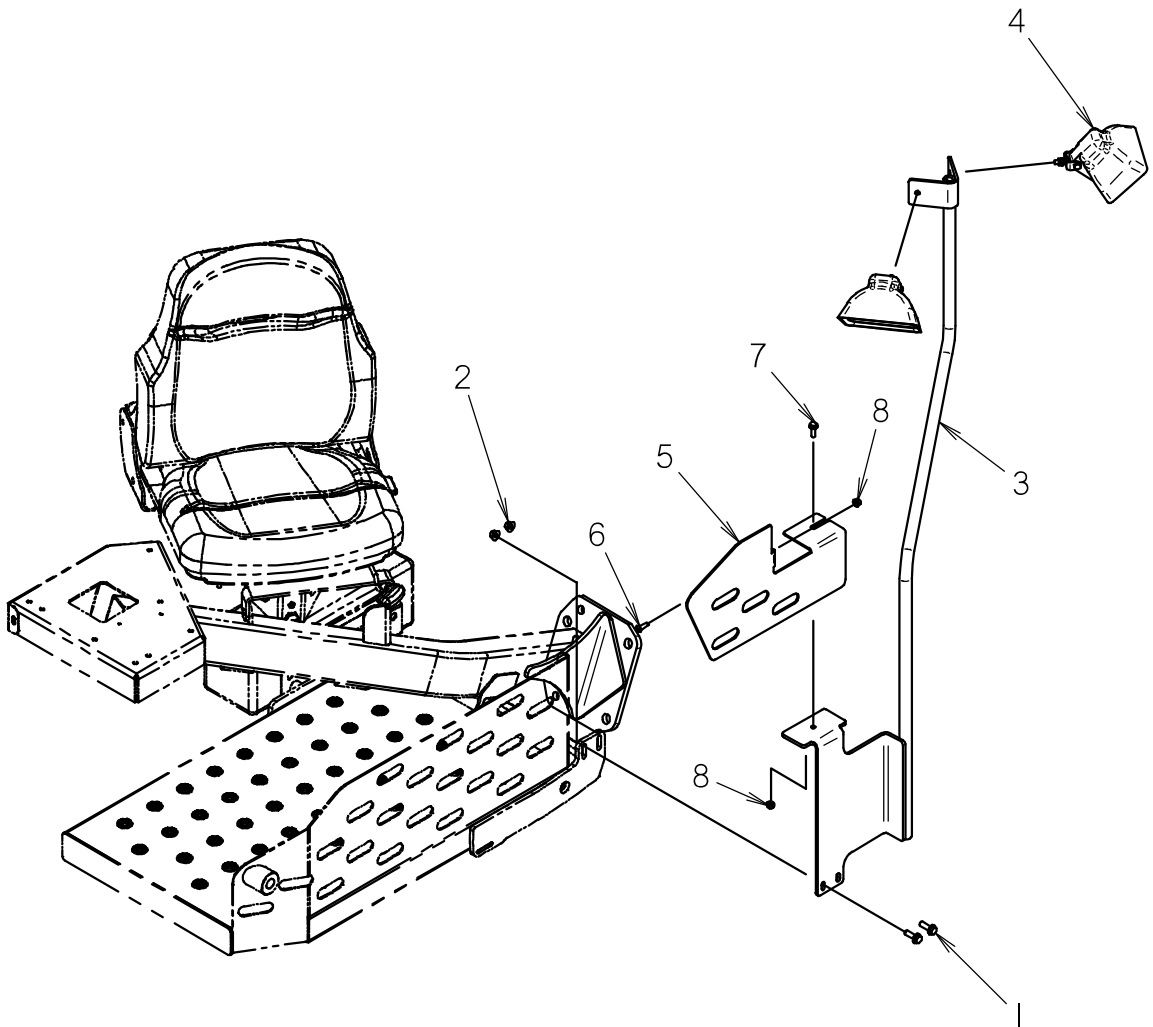

WORK LIGHTS

REF NO.	PART NUMBER	QTY	DESCRIPTION	REMARKS
1	106-383	2	FLG LK SCREW (M10-1.50 X 30MM)	
2	106-387	2	FLG LOCKNUT (M10-1.50)	
3	300-3739	1	WORK LIGHT MOUNT POST	
4	217-057	2	WORKING LIGHT - CLEAR	
5	300-9276	1	GUARD	
6	107-334	1	SCREW (M8-1.25 X 25MM,BUT SOC)	
7	106-381	1	FLG LK SCREW (M8-1.25 X 25MM)	
8	106-386	2	FLG LOCKNUT (M8-1.25)	

NOT SHOWN:

214-791 | 1 WORKLIGHT HARNESS

FOOTNOTES:

NOTE:

OPERATOR'S STATION

OPERATOR STATION SEAT

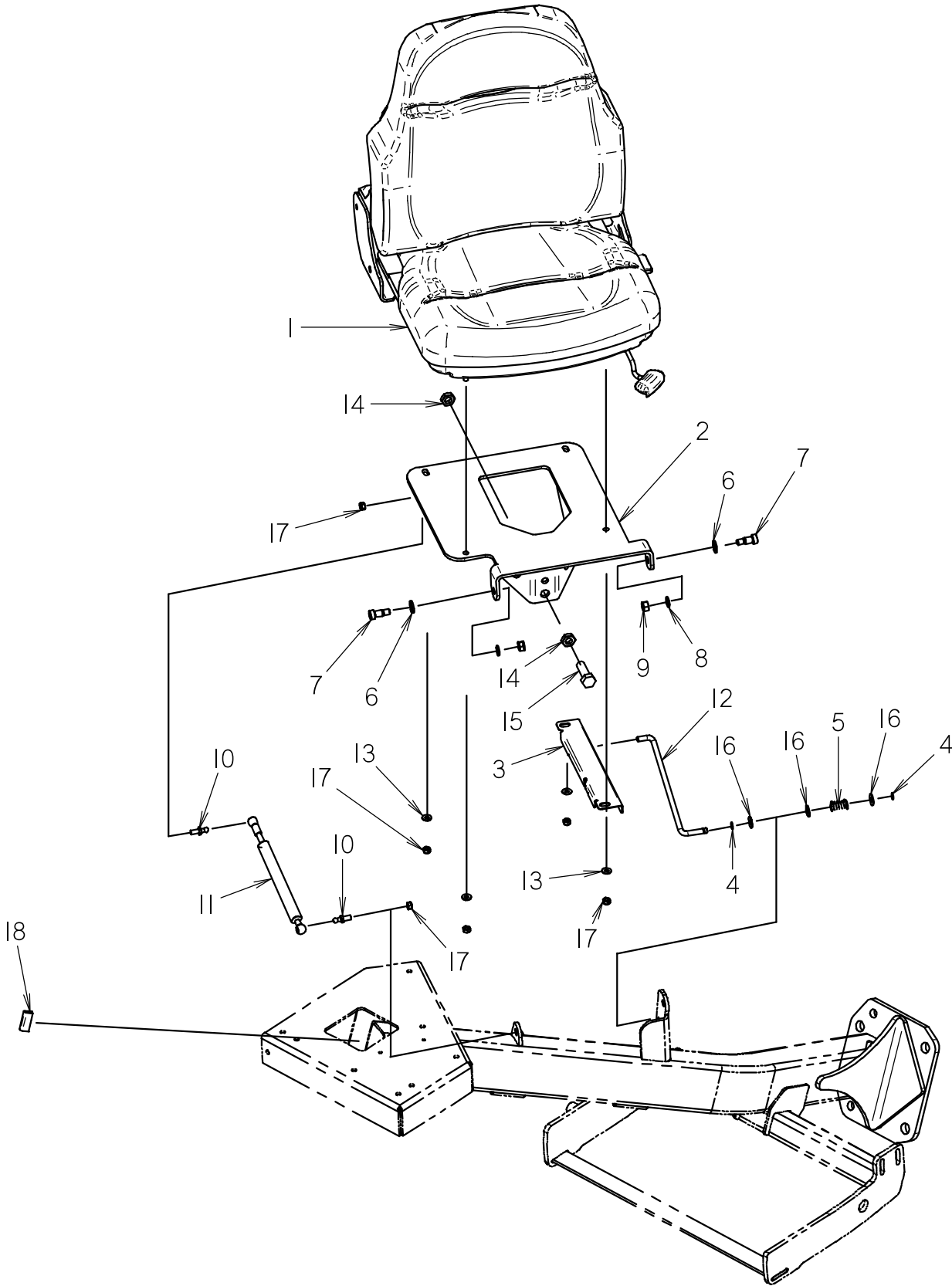

OPERATOR STATION SEAT

REF NO.	PART NUMBER	QTY	DESCRIPTION	REMARKS
1	117-631	1	SEAT ASSEMBLY	
2	329-779	1	SEAT MOUNT	
3	179-980	1	ROD GUIDE	
4	115-477	2	GRIP RING (.375")	
5	115-563	1	COMPRESSION SPRING	
6	106-391	2	WASHER (M12)	
7	107-802	2	SHLD BLT (M12 X 16MM,M10-1.50)	
8	106-390	2	WASHER (M10)	
9	105-894	2	LOCKNUT(M10-1.50,PRV TRQ,10.9)	
10	110-655	2	BALL SCREW (5/16-NC X 1/2")	
11	105-694	1	STRUT (90 LB.)	
12	329-049	1	PROP BAR	
13	105-095	4	WASHER (1/4")	
14	106-775	2	JAM NUT (M16-2.00)	
15	106-340	1	SCREW (M16-2.00 X 50MM)	
16	105-117	3	WASHER (5/16")	
17	105-089	6	LOCKNUT (5/16-NC)	
18	115-704	10	BULK EDGE (1/4", SOLD PER 1")	1 @ 10"

NOT SHOWN:

FOOTNOTES:

NOTE:

OPERATOR STATION FLOOR

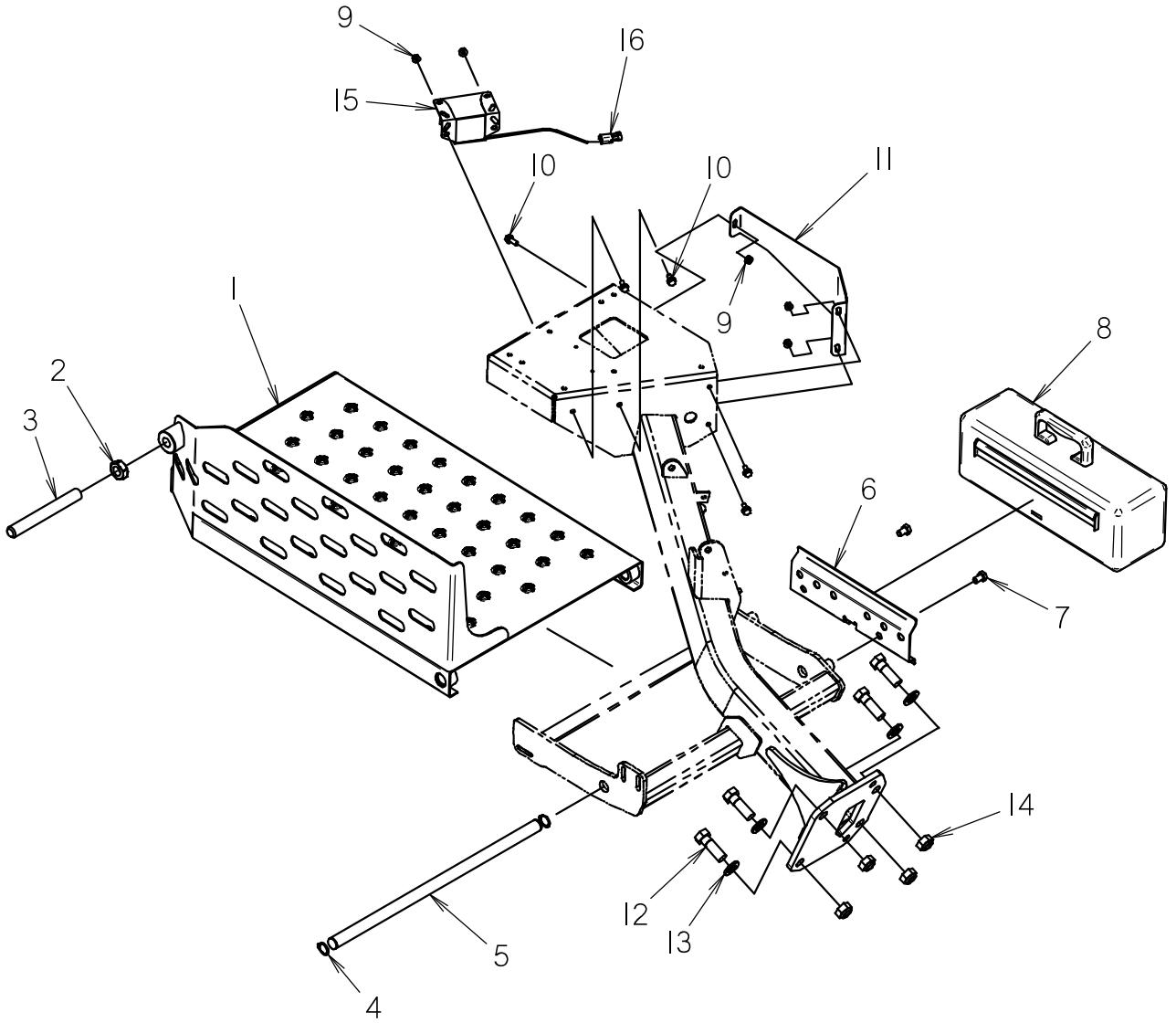

OPERATOR STATION FLOOR

REF NO.	PART NUMBER	QTY	DESCRIPTION	REMARKS
1	300-2911	1	FLOOR	
2	106-033	1	JAM NUT (I-NCI)	
3	300-2913	1	LIFT BAR	
4	115-484	2	EXTERNAL SNAP RING (1.000")	
5	177-295	1	PIN	
6	313-777	1	BRACKET	
7	107-521	2	SCREW (M12-1.75 X 20MM)	
8	313-776	1	TOOL BOX	
9	106-386	5	FLG LOCKNUT (M8-1.25)	
10	106-162	5	FLG SCREW (M8-1.25 X 20MM, GD8)	
11	329-771	1	COVER	
12	106-075	4	SCREW (M20-2.50 X 60MM, 10.9)	SEE FOOTNOTE 1
13	106-399	4	WASHER (M20, HARDENED)	SEE FOOTNOTE 1
14	106-665	4	LOCKNUT (M20-2.50, 10.9)	SEE FOOTNOTE 1
15	306-602	1	ALARM	
16	214-103	1	(2-WAY) MALE CONNECTOR	

NOT SHOWN:

214-104 2 PACKARD MALE TERMINAL
157-645 2 WEATHER-PAC SEAL (2.80MM)

FOOTNOTES:

1. BEGINS WITH S/N: CMWJ30MIHA0000391 AND CMWJ30ATCA0000254.
UNITS WITH S/N: CMWJ30MIHA0000387 AND CMWJ30ATCA0000254 AND BEFORE USE 2X 106-616 SCREW (M16 X 55MM), 2X 106-545 M16 LCK NUT, 4X 106-398 WASHER & 2X 106-478 SCREW (M16 X 40MM).

NOTE:

LEFT CONSOLE

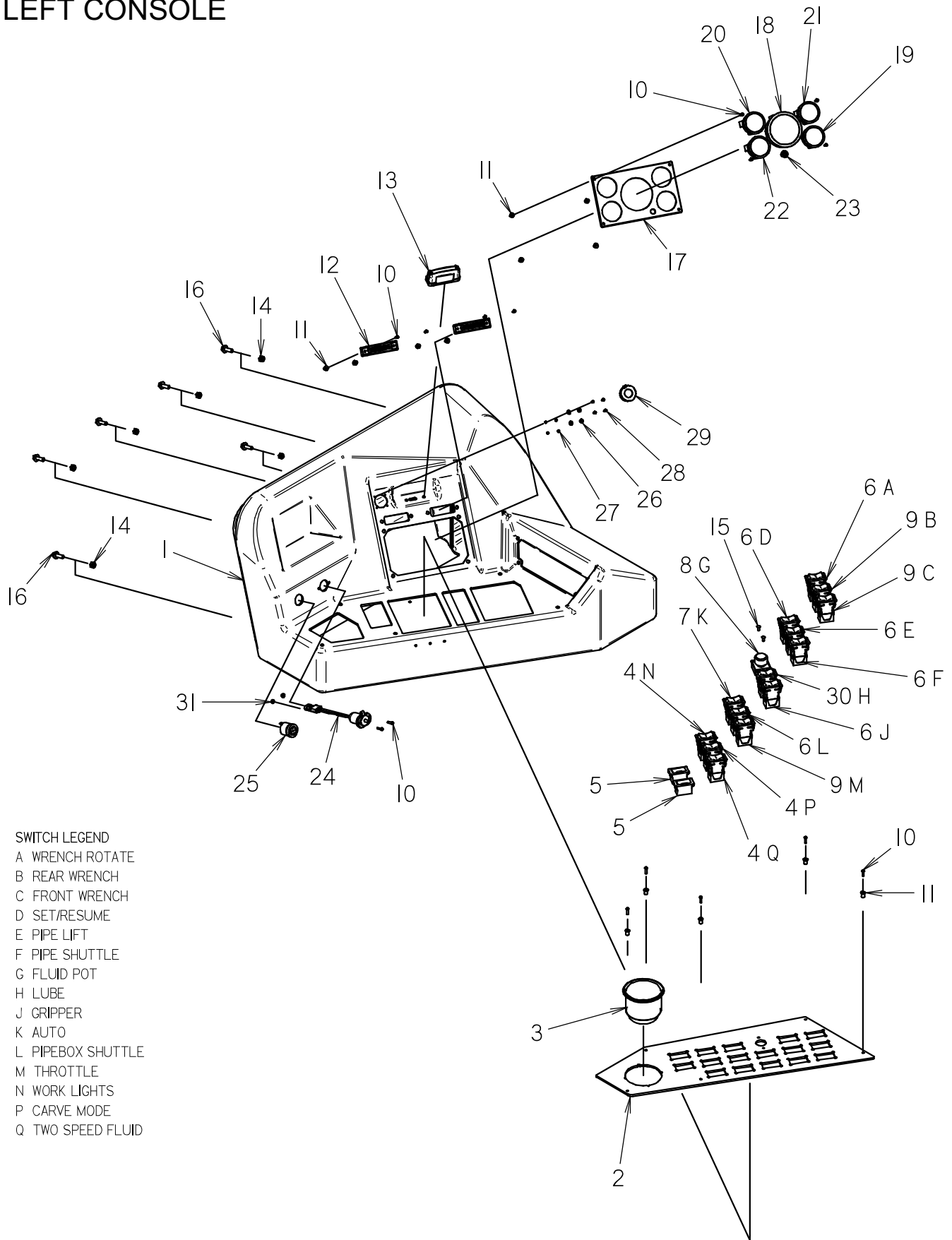

- SWITCH LEGEND
- A WRENCH ROTATE
 - B REAR WRENCH
 - C FRONT WRENCH
 - D SET/RESUME
 - E PIPE LIFT
 - F PIPE SHUTTLE
 - G FLUID POT
 - H LUBE
 - J GRIPPER
 - K AUTO
 - L PIPEBOX SHUTTLE
 - M THROTTLE
 - N WORK LIGHTS
 - P CARVE MODE
 - Q TWO SPEED FLUID

LEFT CONSOLE

REF NO.	PART NUMBER	QTY	DESCRIPTION	REMARKS
1	363-718	1	LEFT CONSOLE	
2	362-1025	1	SWITCH PANEL	
3	308-888	1	CUP HOLDER	
4	217-907	3	ROCKER SWITCH (DPDT) ON-ON	
5	110-962	2	FILLER PLUG	
6	222-145	6	ROCKER SWITCH DPDT(ON-ON-ION)	
7	217-916	1	ROCKER SWITCH (DPDT) ON-OFF-ON	
8	214-566	1	POTENTIOMETER	
9	217-908	3	ROCKER SWITCH DPDT ON-ON-ION)	
10	107-580	15	SCREW (M4-0.70 X 16MM,BUT SOC)	
11	107-358	13	WELLNUT (M4-0.7 X 12.67MM LG)	
12	220-664	2	INDICATOR ASSEMBLY	
13	217-275	1	CONSOLE LIGHT	
14	106-386	6	FLG LOCKNUT (M8-1.25)	
15	110-560	2	POP RIVET (3/16" X 1/2", ALUM)	
16	106-381	6	FLG LK SCREW (M8-1.25 X 25MM)	
17	363-696	1	GAUGE CLUSTER PANEL	
18	211-325	1	3.5" CAN TACHOMETER W/ DISPLAY	
19	215-1268	1	2.06" CAN ENG OIL PRESS GAUGE	
20	211-329	1	2.06" FUEL GAUGE	
21	215-1267	1	2.06" CAN COOLANT TEMP GAUGE	
22	211-328	1	2.06" VOLTMETER GAUGE	
23	215-1015	1	MOMENTARY PUSH BUTTON SWITCH	
24	214-301	1	ACCESSORY SOCKET	SEE FOOTNOTE I
25	306-603	1	AUDIO ALARM	
26	106-013	4	WASHER (3/16")	
27	105-662	4	NUT (#4-40)	
28	106-155	4	SCREW (#4-40 X 5/8", PAN)	
29	213-035	1	DUST CAP W/ LANYARD	
30	215-1210	1	ROCKER SWITCH ON-ION)	
31	105-680	2	NUT (M4, W/LK WSHR)	

NOT SHOWN:

FOOTNOTES:

I. INCLUDES 214-103 (2-WAY) MALE CONNECTOR

NOTE:

LEFT CONSOLE AT/JT CONTROL PANEL

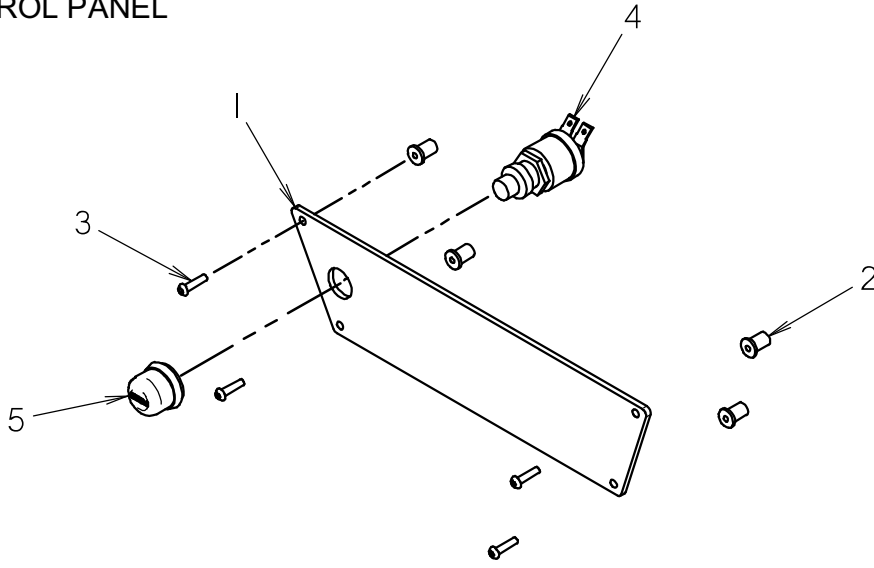

"JT" ASSEMBLY

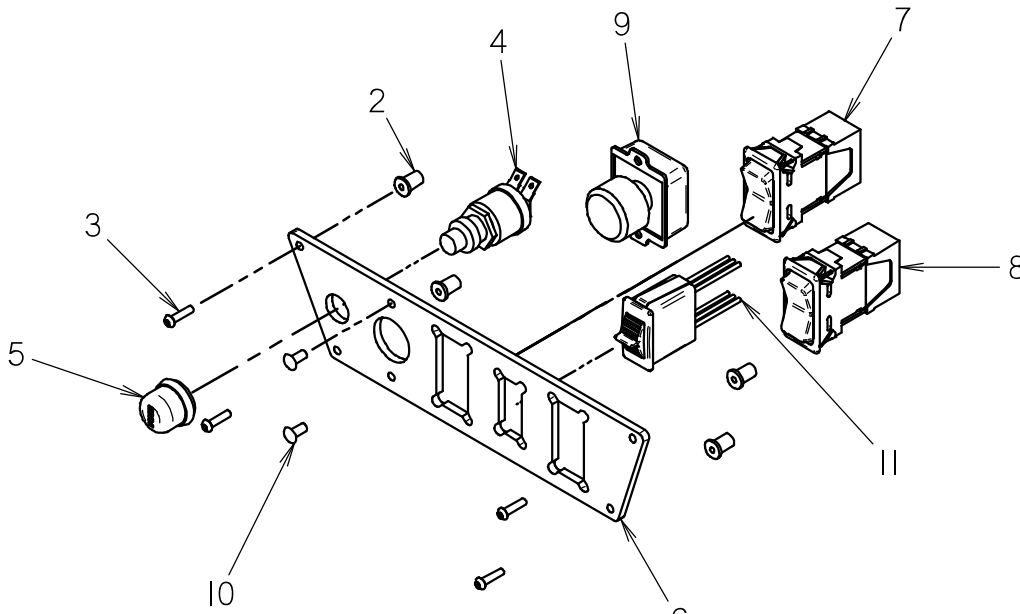

"AT" ASSEMBLY

LEFT CONSOLE AT/JT CONTROL PANEL

REF NO.	PART NUMBER	QTY	DESCRIPTION	REMARKS
1	363-719	1	J/T CONTROL PANEL	USE ON "JT" OPTION ONLY
2	107-358	4	WELLNUT (M4-0.7 X 12.67MM LG)	
3	107-580	4	SCREW (M4-0.70 X 16MM,BUT SOC)	
4	306-607	1	HORN BUTTON	
5	306-608	1	BUTTON COVER	
6	362-1024	1	A/T CONTROL PANEL	USE ON "AT" OPTION ONLY
7	217-912	1	ROCKER SWITCH (DPDT) ON-ON-ON	USE ON "AT" OPTION ONLY
8	217-907	1	ROCKER SWITCH (DPDT) ON-ON	USE ON "AT" OPTION ONLY
9	214-566	1	POTENTIOMETER	USE ON "AT" OPTION ONLY
10	110-560	2	POP RIVET (3/16" X 1/2", ALUM)	USE ON "AT" OPTION ONLY
11	215-1016	1	ROTATION DITHER SWITCH	USE ON "AT" OPTION ONLY

NOT SHOWN:

FOOTNOTES:

NOTE:

WEATHER COVERS

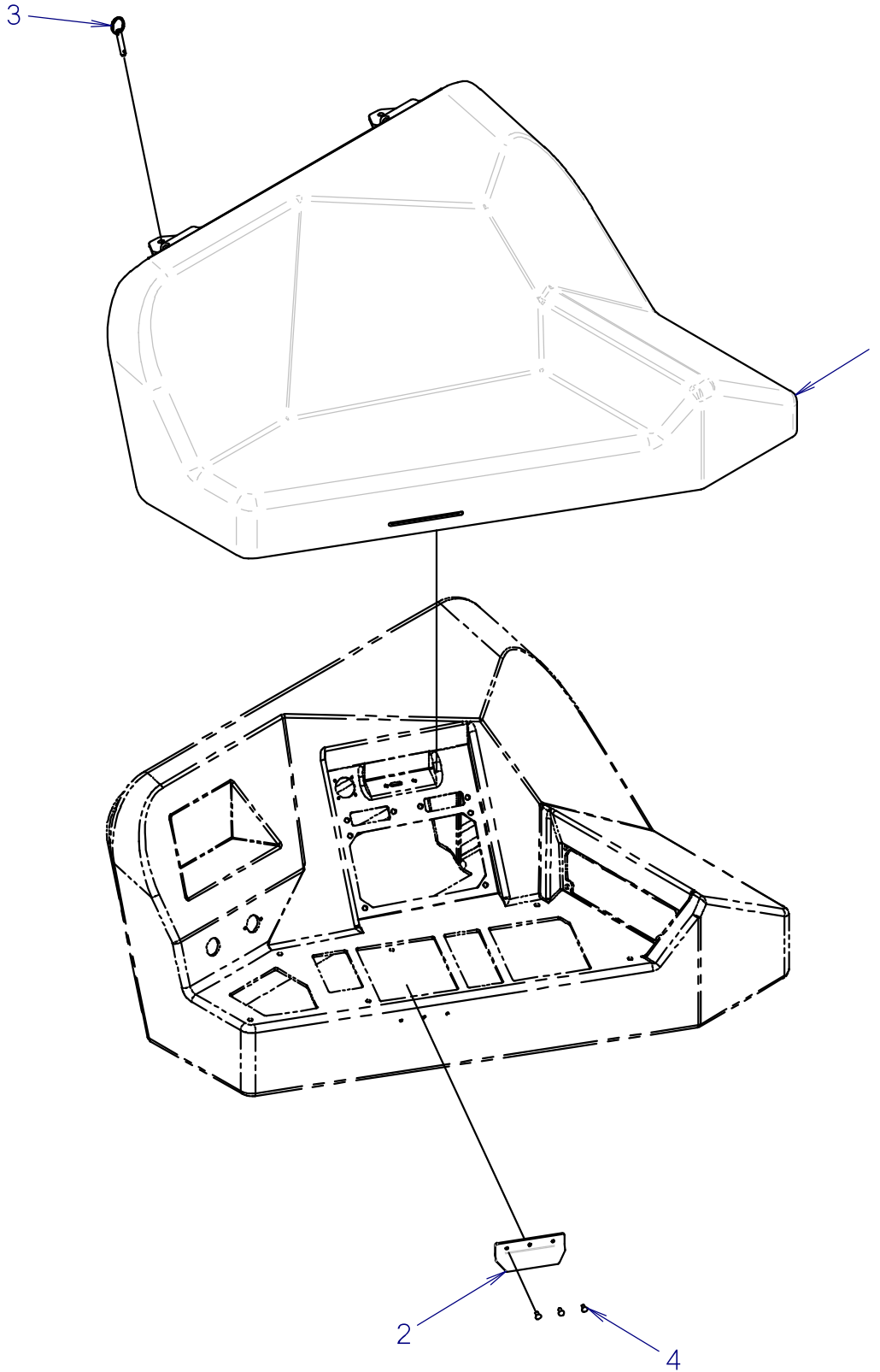

WEATHER COVERS

REF NO.	PART NUMBER	QTY	DESCRIPTION	REMARKS
1	362-1097	1	WEATHER COVER	
2	300-3589	1	BRACKET	
3	110-737	2	PULL PIN (5/16" X 2")	
4	110-560	3	POP RIVET (3/16" X 1/2", ALUM)	

NOT SHOWN:

FOOTNOTES:

NOTE:

RIGHT CONSOLE AND JOYSTICK

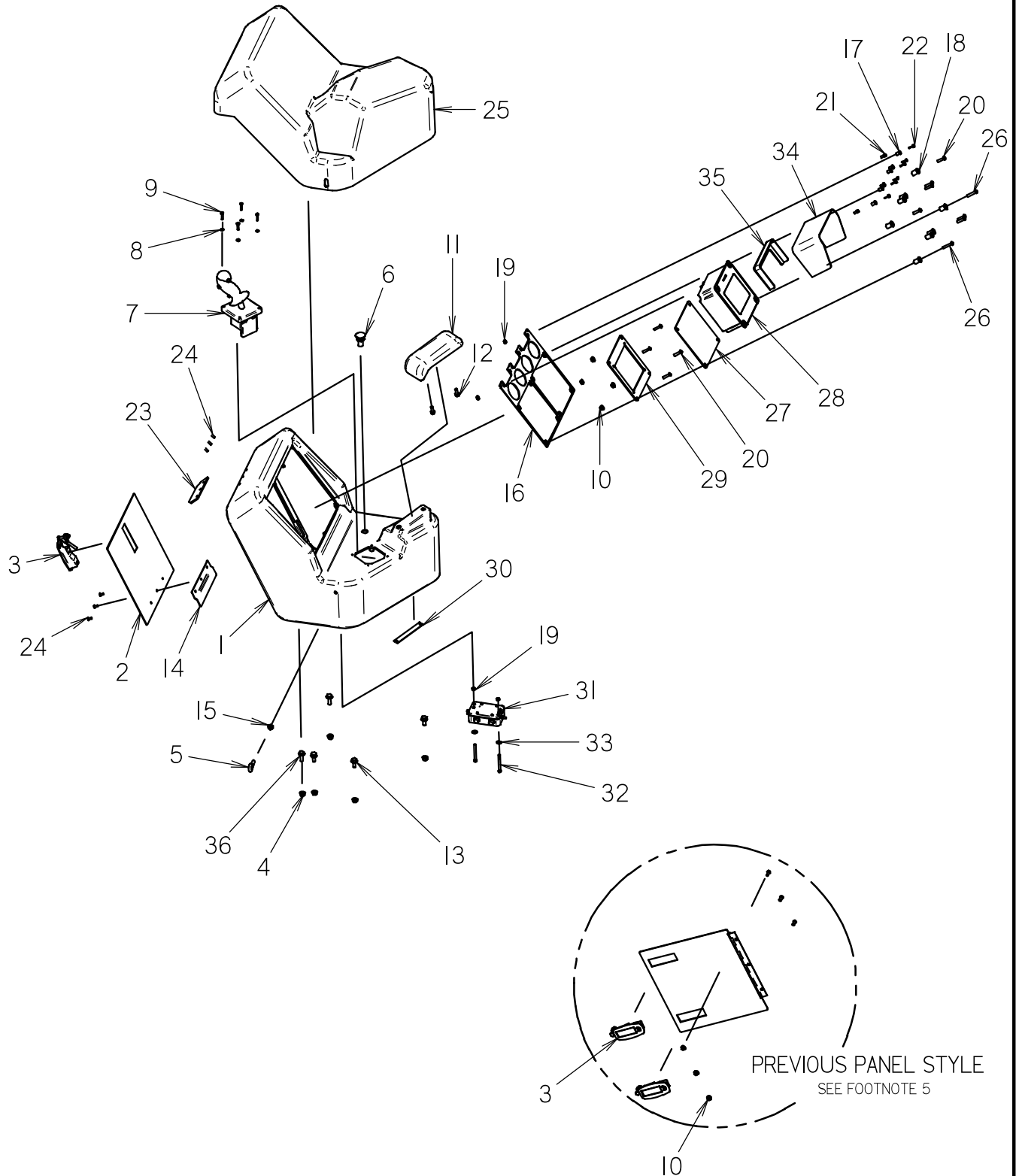

RIGHT CONSOLE AND JOYSTICK

REF NO.	PART NUMBER	QTY	DESCRIPTION	REMARKS
1	363-717	1	RIGHT CONSOLE	
2	300-5510	1	ACCESS PANEL	SEE FOOTNOTE 5
3	117-558	1	LATCH, ADJUST LEVER (LOCKING)	
4	106-386	5	FLG LOCKNUT (M8-1.25)	
5	107-570	1	EYE BOLT (M8-1.25 X 20MM)	
6	217-206	1	BUTTON SWITCH (SPST)	
7	215-1224	1	DUAL AXIS HALL EFFECT JOYSTICK	
8	106-205	4	WASHER (191")	
9	106-556	4	SCREW (M4-0.70 X 20MM)	
10	106-385	4	FLG LOCKNUT (M6-1.00)	
11	117-314	1	ARM REST	
12	106-159	2	FLG SCREW (1/4-NC X 3/4")	
13	106-162	3	FLG SCREW (M8-1.25 X 20MM, GD8)	
14	300-5511	1	BRACKET	
15	106-078	1	NUT (M8-1.25)	
16	300-3972	1	GAUGE MOUNT PANEL	
17	107-358	6	WELLNUT (M4-0.7 X 12.67MM LG)	
18	107-871	8	WELLNUT (M6-1.00 X 20.35MM LG)	
19	106-048	4	LOCKNUT (#10-24)	
20	107-312	10	SCREW (M6-1.00 X 25MM, BUT SOC)	
21	501-343	2	BOLT (#10-24 X 1/2", SOC)	
22	107-393	6	SCREW (M4-0.70 X 16MM, BX)	
23	300-4476	1	BRACKET	
24	110-560	6	POP RIVET (3/16" X 1/2", ALUM)	
25	362-1091	1	WEATHER COVER	
26	105-1179	2	SCREW (M6-1.00 X 35MM, BUT SOC)	
27	300-3568	1	DISPLAY COVER	
28	220-1007	1	INFORMATION CENTER DISPLAY MODULE	
29	300-4501	1	ADAPTER PLATE	USE WITH 750/752 REMOTE DISPLAY
30	300-6573	1	CLAMP PLATE	
31	215-1346	1	CMW CAN / J1939 J-BOX	SEE FOOTNOTE 1 & 2
32	107-895	2	SCREW #10-24 X 2 1/4" SOC HEAD	SEE FOOTNOTE 1, 3 & 4
33	105-284	2	WASHER (3/16")	SEE FOOTNOTE 1
34	362-1289	1	VISOR	
35	300-6590	1	VISOR LEDGE	
36	106-381	2	FLG LK SCREW (M8-1.25 X 25MM)	

NOT SHOWN:

214-415 | 90D MODULE TO RIG CABLE
 214-414 | RIG RF CABLE 4270MM
 215-1097 | GROUND CABLE

TO STARTER GROUND LUG TO ENGINE BLOCK

FOOTNOTES:

- BEGINS WITH S/N: "JT" CMWJ30MIL80000044, "AT" CMWJ30ATV80000032
- 213-359 CAN WITCH/J1939 J-BOX ENDS WITH S/N: "JT" CMWJ30MIA80000043, "AT" CMWJ30ATV80000029
- 105-224 BOLT (1/4-NC X 2-1/2") ENDS WITH S/N: "JT" CMWJ30MIA80000043, "AT" CMWJ30ATV80000029
- 105-832 FLG LOCKNUT (1/4-NC) ENDS WITH S/N: "JT" CMWJ30MIA80000043, "AT" CMWJ30ATV80000029
- PREVIOUS CONSOLE ACCESS PANEL TO INCLUDE FOLLOWING PARTS: 363-721 ACCESS PANEL, 107-193 SCREW (M6-1.00 X 16MM, BUT SOC), REF #10 & REF #3

NOTE:

GAUGES

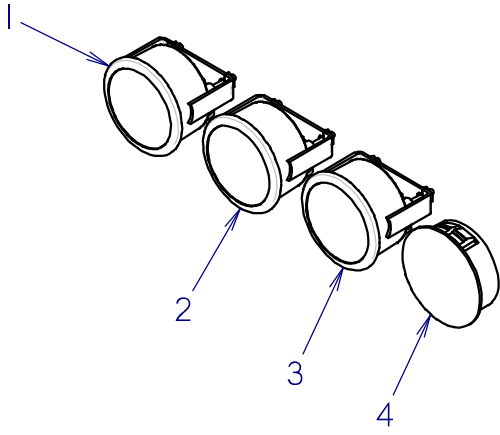

"JT" ENGLISH ASSEMBLY

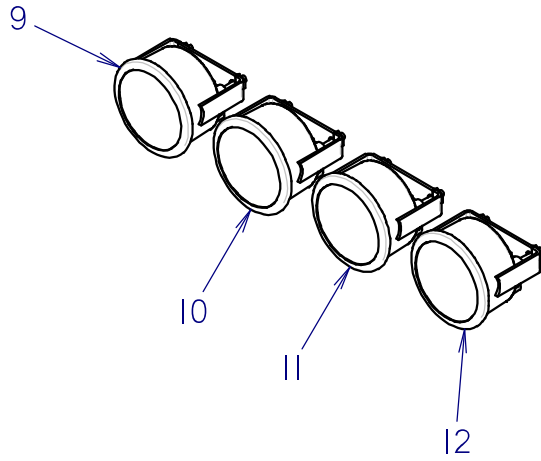

"AT" ENGLISH ASSEMBLY

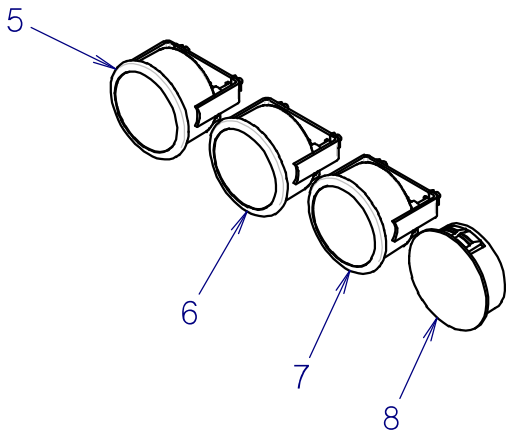

"JT" METRIC ASSEMBLY

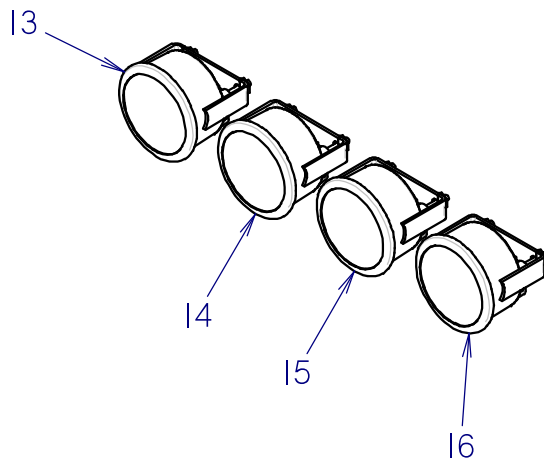

"AT" METRIC ASSEMBLY

GAUGES

REF NO.	PART NUMBER	QTY	DESCRIPTION	REMARKS
1	211-335	1	ROTATION PRESSURE GAUGE	
2	211-333	1	THRUST PRESSURE GAUGE	
3	211-336	1	DRILLING FLUID PRESSURE GAUGE	
4	111-067	1	EXPANSION PLUG (2.125")	
5	150-1624	1	ROTATION PRESSURE GAUGE (METRIC)	
6	150-1625	1	THRUST PRESSURE GAUGE (METRIC)	
7	150-1626	1	DRILLING FLUID PRESSURE GAUGE (METRIC)	USE FOR "JT" METRIC MACHINES ONLY
8	111-067	1	EXPANSION PLUG (2.125")	
9	211-335	1	ROTATION PRESSURE GAUGE	
10	211-333	1	THRUST PRESSURE GAUGE	
11	211-336	1	DRILLING FLUID PRESSURE GAUGE	
12	211-334	1	INN ROT PRESSURE GAUGE	USE FOR "AT" ENGLISH MACHINES ONLY
13	150-1624	1	ROTATION PRESSURE GAUGE (METRIC)	
14	150-1625	1	THRUST PRESSURE GAUGE (METRIC)	
15	150-1626	1	DRILLING FLUID PRESSURE GAUGE (METRIC)	
16	150-1671	1	INNER ROTATION PRESSURE GAUGE (METRIC)	USE FOR "AT" METRIC MACHINES ONLY

NOT SHOWN:

FOOTNOTES:

NOTE:

ELECTRICAL STRIKE SYSTEM

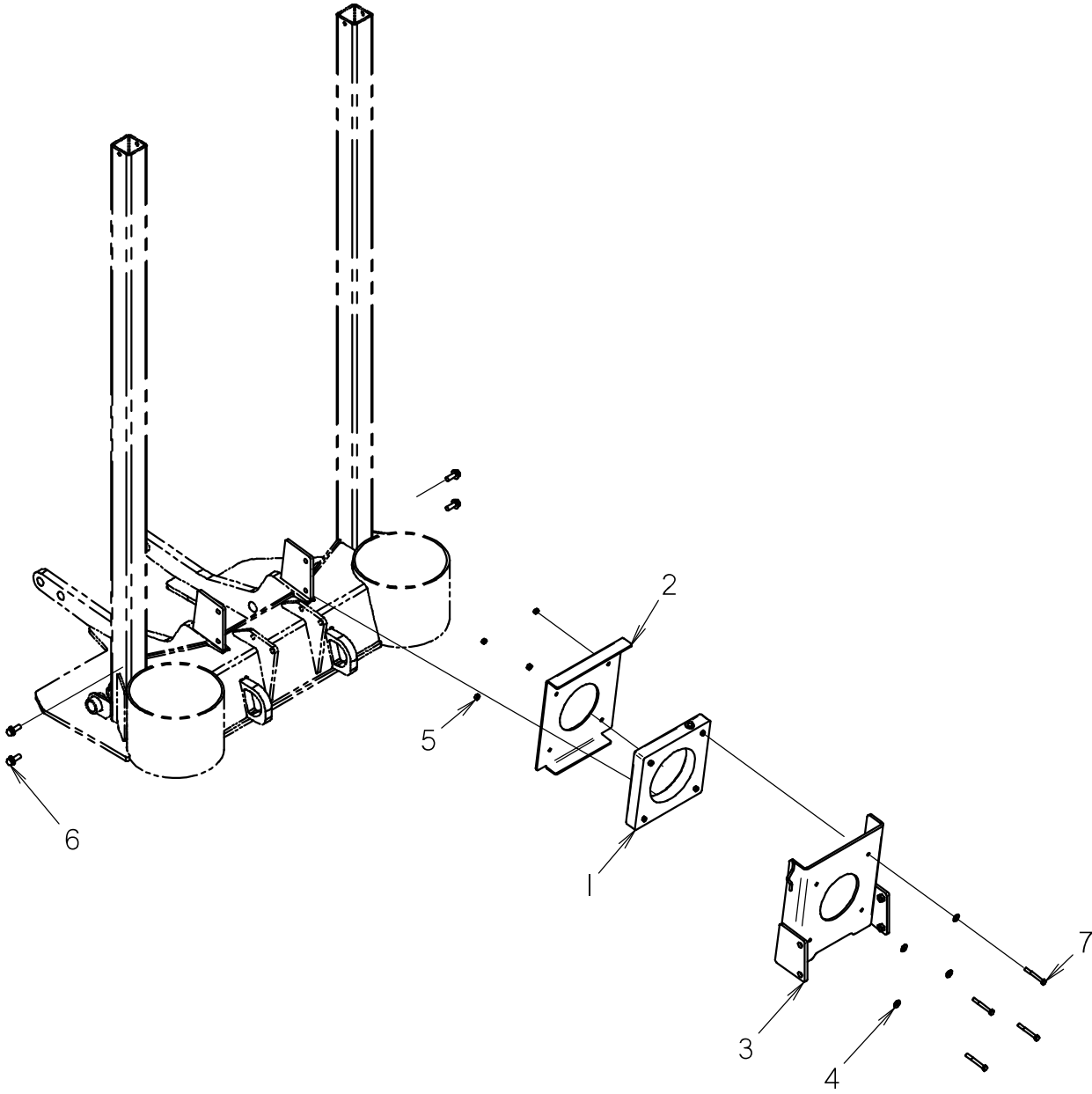

ELECTRICAL STRIKE SYSTEM

REF NO.	PART NUMBER	QTY	DESCRIPTION	REMARKS
1	211-084	1	CURRENT TRANSFORMER	
2	300-2194	1	COIL COVER	
3	300-2195	1	COIL MOUNT	
4	105-117	4	WASHER (5/16")	
5	106-561	4	LOCKNUT (M8-1.25,PRV TRQ,10,9)	
6	106-469	4	FLG SCREW (M12-1.75 X 30MM)	
7	106-330	4	SCREW (M8-1.25 X 70MM)	

NOT SHOWN:

217-296	1	STROBE LIGHT AMBER	SEE FOOTNOTE 1
215-799	1	VOLTAGE STAKE	
211-042	1	VOLTAGE LIMITER CABLE	
214-550	1	CURRENT COIL CABLE	

FOOTNOTES:

1.	214-103	1	(2-WAY) MALE CONNECTOR
	214-104	2	PACKARD MALE TERMINAL
	157-645	2	WEATHER-PAC SEAL (2.80MM)

NOTE:

GROUND DRIVE CONTROL

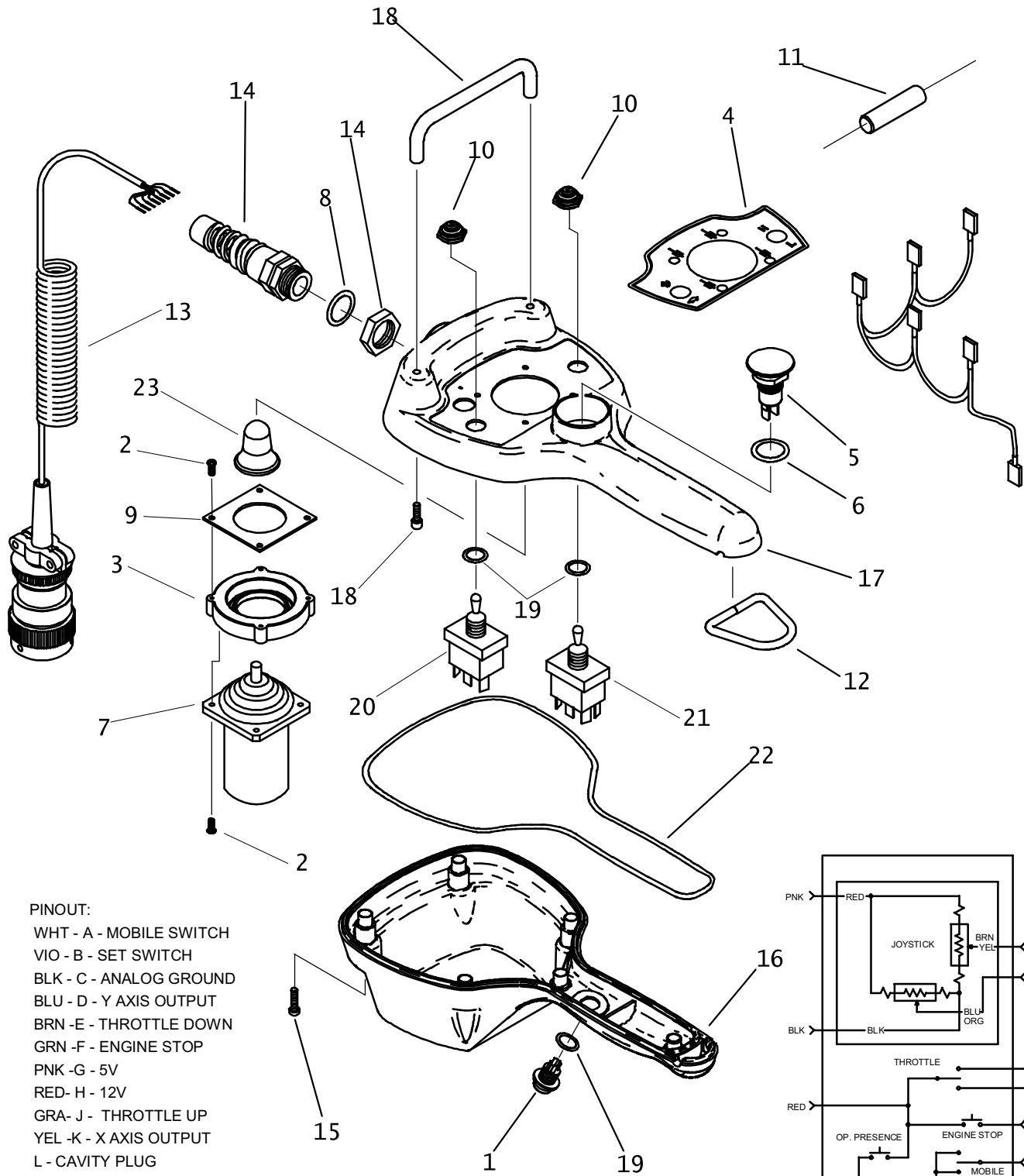

- PINOUT:**
 WHT - A - MOBILE SWITCH
 VIO - B - SET SWITCH
 BLK - C - ANALOG GROUND
 BLU - D - Y AXIS OUTPUT
 BRN - E - THROTTLE DOWN
 GRN - F - ENGINE STOP
 PNK - G - 5V
 RED - H - 12V
 GRA - J - THROTTLE UP
 YEL - K - X AXIS OUTPUT
 L - CAVITY PLUG
 M - CAVITY PLUG
 N - CAVITY PLUG
 P - CAVITY PLUG

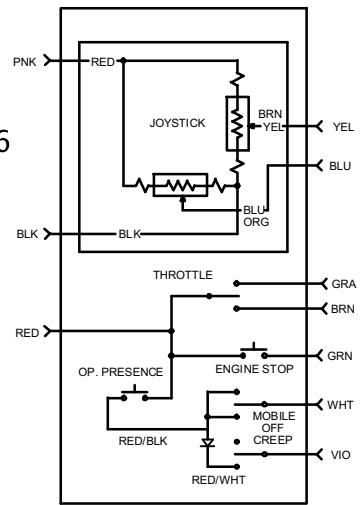

GROUND DRIVE CONTROL

REF NO.	PART NUMBER	QTY	DESCRIPTION	REMARKS
	214-589		GROUND DRIVE CONTROL	
1.	214-614	1	PUSH BUTTON SWITCH (SPST) OFF-ON	
2.	106-820	8	SCREW, SELF TAPPING (3.0 X 12MM)	
3.	305-664	1	JOY STICK ADAPTER	
4.	274-998	1	DECAL	
5.	214-615	1	KILL SWITCH	
6.	157-040	1	O-RING (-016 D90)	
7.	214-613	1	JOYSTI K ASSEMBLY	SEE FOOTNOTE 1
	215-1394	1	JOYSTICK ASSEMBLY	SEE FOOTNOTE 1
8.	157-017	1	O-RING (.018 D90)	
9.	149-558	1	JOYSTICK GASKET	
10.	214-728	2	TOGGLE SWITCH HALF BOOT (SEAL)	
11.	215-1720	1	DIODE IN5402	
12.	105-775	1	D-RING	
13.	211-020	1	COILED CORD-MALE	
14.	211-021	1	STRAIN RELIEF	
15.	106-876	6	SCREW	
16.	214-497	1	LOWER HOUSING	
17.	214-498	1	UPPER HOUSING	
18.	116-933	1	HANDLE	
	106-894	2	SCREW (#8-32 X 1" PLPS SSI)	SEE FOOTNOTE 2
19.	157-039	2	O-RING (-014 D90)	
20.	217-896	1	TOGGLE SWITCH	
21.	214-570	1	TOGGLE SWITCH (DPDT) ON-OFF-ON	
22.	116-549	AR	ROPE GASKET (USE 27")	
23.	116-932	1	JOYSTICK KNOB	

NOT SHOWN:

FOOTNOTES:

1. JOYSTICK SHOULD BE ORIENTED WITH LABEL POINTING TOWARDS CABLE END. (REV G)
1. JOYSTICK SHOULD BE ORIENTED WITH X+ ON LABEL POINTING TOWARDS CABLE END. (REV H)
 Y-AXIS OUTPUT: 3.75V FORWARD 1.25V BACK
 X-AXIS OUTPUT: 3.75V LEFT 1.25V RIGHT

2. APPLY THREAD LOCKING COMPOUND TO BOTH HANDLE SCREWS.

NOTE:

HYDRAULICS

FILTER AND RESERVOIR HYDRAULICS

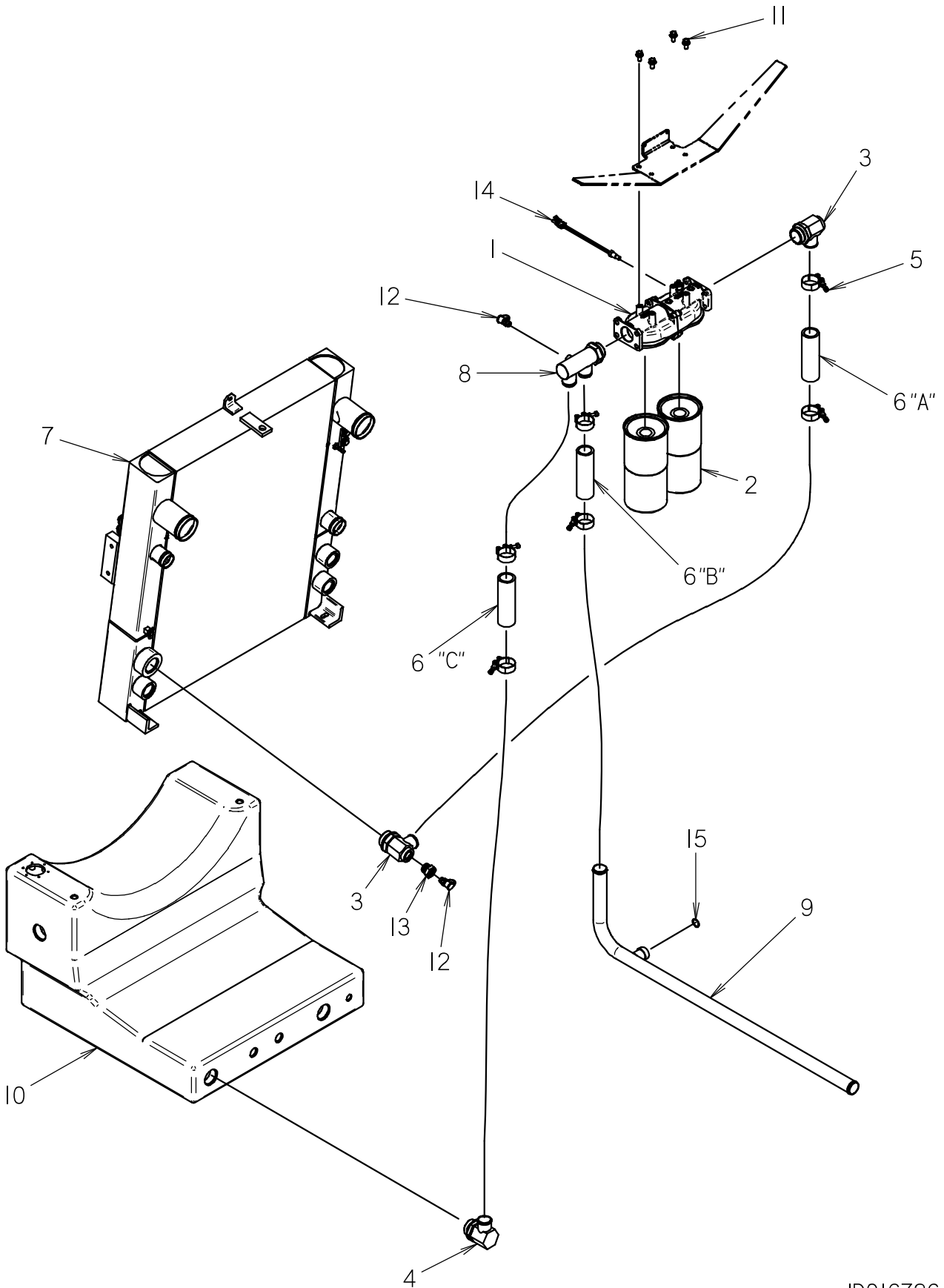

FILTER AND RESERVOIR HYDRAULICS

REF NO.	PART NUMBER	QTY	DESCRIPTION	REMARKS
1	150-1203	1	FILTER HEAD	
2	153-791	2	FILTER ELEMENT (5 MICRON)	153-792; SEE FOOTNOTE 4
3	150-1622	2	S/O COUPLER (24S-24H-12SF 90)	SEE FOOT NOTE 3
4	514-135	1	S/O COUPLER (24S-24H90)	
5	111-028	6	T-BOLT CLAMP (1.75"-2.00")	
6	116-588	79	BULK HOSE (1-1/2",SOLD PER FT)	SEE FOOTNOTE 1
7	194-841	1	COOLER	
8	150-1151	1	S/O COUPLER (24S-24H-24H-06SF90)	
9	150-1091	1	HYDRAULIC LINE	SEE FOOTNOTE 2
10	364-731	1	HYDRAULIC TANK	
11	105-825	4	FLG LK BOLT (3/8-NC X 3/4)	
12	159-147	2	QDC ADAPTER (02-06S)	
13	155-129	1	REDUCER (12S-06SF)	
14	214-854	1	TEMPERATURE SWITCH(1/4NPT,MALE)	
15	155-714	1	O-RING (021 D90)	

NOT SHOWN:

FOOTNOTES:

1. REF. #6 "A" I @ 30"
REF. #6 "B" I @ 21"
REF. #6 "C" I @ 28"
2. USE 154-329 CAP (16 OF) FOR "JT" APPLICATION ON SPUD
3. USE 159-392 PLUG (12S, SOC) ON "JT" ONLY, FOR "AT" APPLICATION SEE INNER ROTATION PUMP HYDRAULICS PAGE ID0177783
4. 153-791 IS USED ON NEW MACHINES FOR 50 HRS AND AFTER HOSE OR COMPONENT REPLACEMENT. USE 153-792 FOR NORMAL MAINTENANCE.

NOTE:

HYDRAULIC RESERVOIR

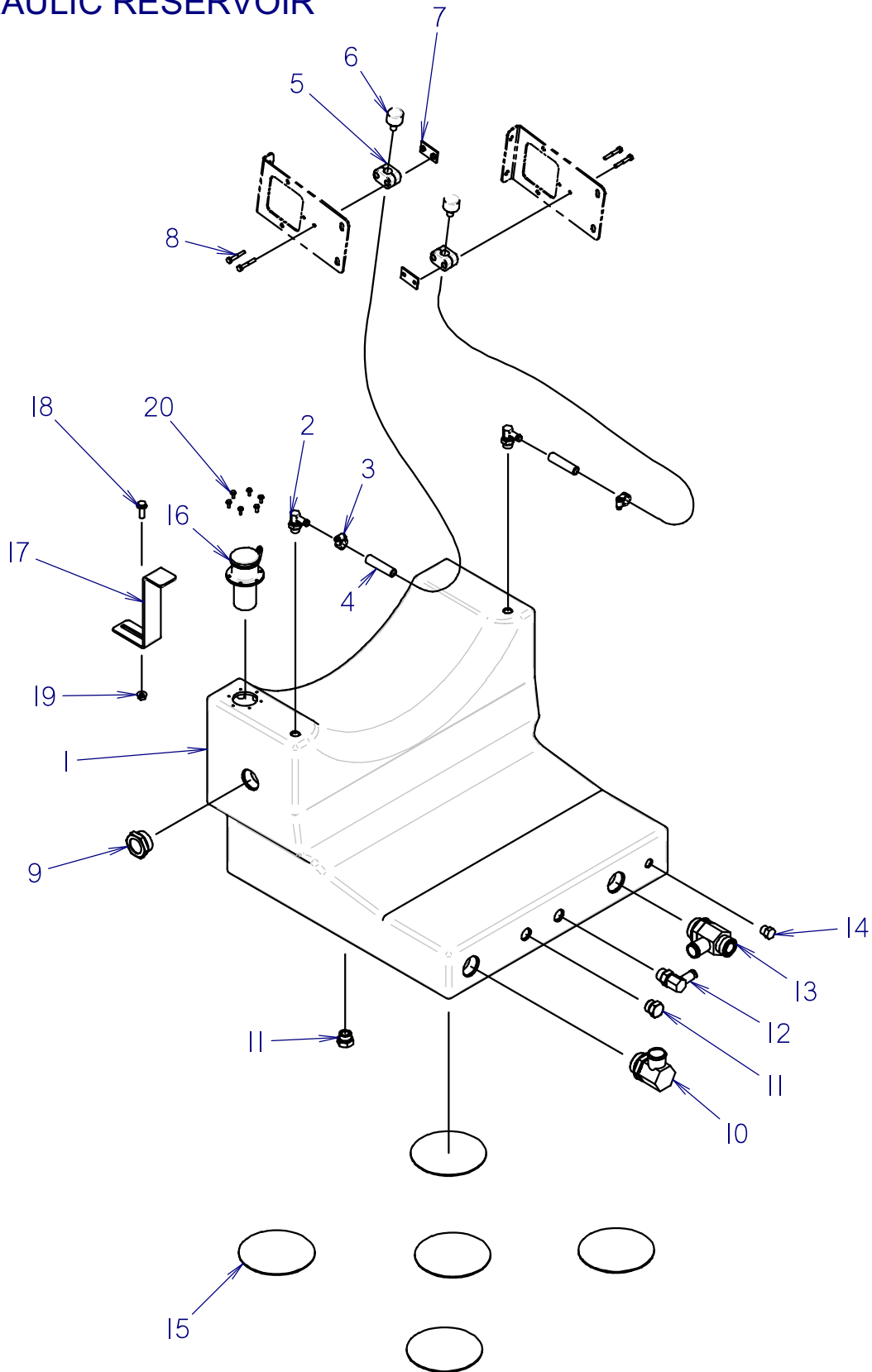

HYDRAULIC RESERVOIR

REF NO.	PART NUMBER	QTY	DESCRIPTION	REMARKS
1	364-731	1	HYDRAULIC TANK	
2	514-297	2	S/O COUPLER (08S-08H90)	
3	110-217	2	WORM CLAMP (7/16" TO 1")	
4	116-322	20	BULK HOSE (1/2",SOLD PER 1")	2 @ 10"
5	110-411	2	BOLT-ON CLAMP (3/4", SET)	
6	111-021	2	BREATHER CAP (TANK)	
7	322-290	2	MOUNT (WELD-ON)	
8	105-198	4	BOLT (1/4-NC X 1-3/4")	
9	121-059	1	SIGHT GLASS (24)	
10	514-135	1	S/O COUPLER (24S-24H90)	
11	500-302	2	PLUG (12 S)	
12	155-174	1	S/O COUPLER (12S-12H90)	
13	150-1152	1	S/O COUPLER (24S-200-20H)	
14	154-381	1	PLUG (08S)	
15	117-425	AR	LINER PAD (1/2" THK)	
16	364-567	1	FILL NECK	
17	327-884	1	TIE DOWN STRAP	
18	106-164	1	FLG LK SCREW (M10-1.50 X 30MM)	
19	106-387	1	FLG LOCKNUT (M10-1.50)	
20	105-214	6	FLG SCREW (#10-24 X .5")	

NOT SHOWN:

FOOTNOTES:

NOTE:

HYDRAULIC OIL COOLER

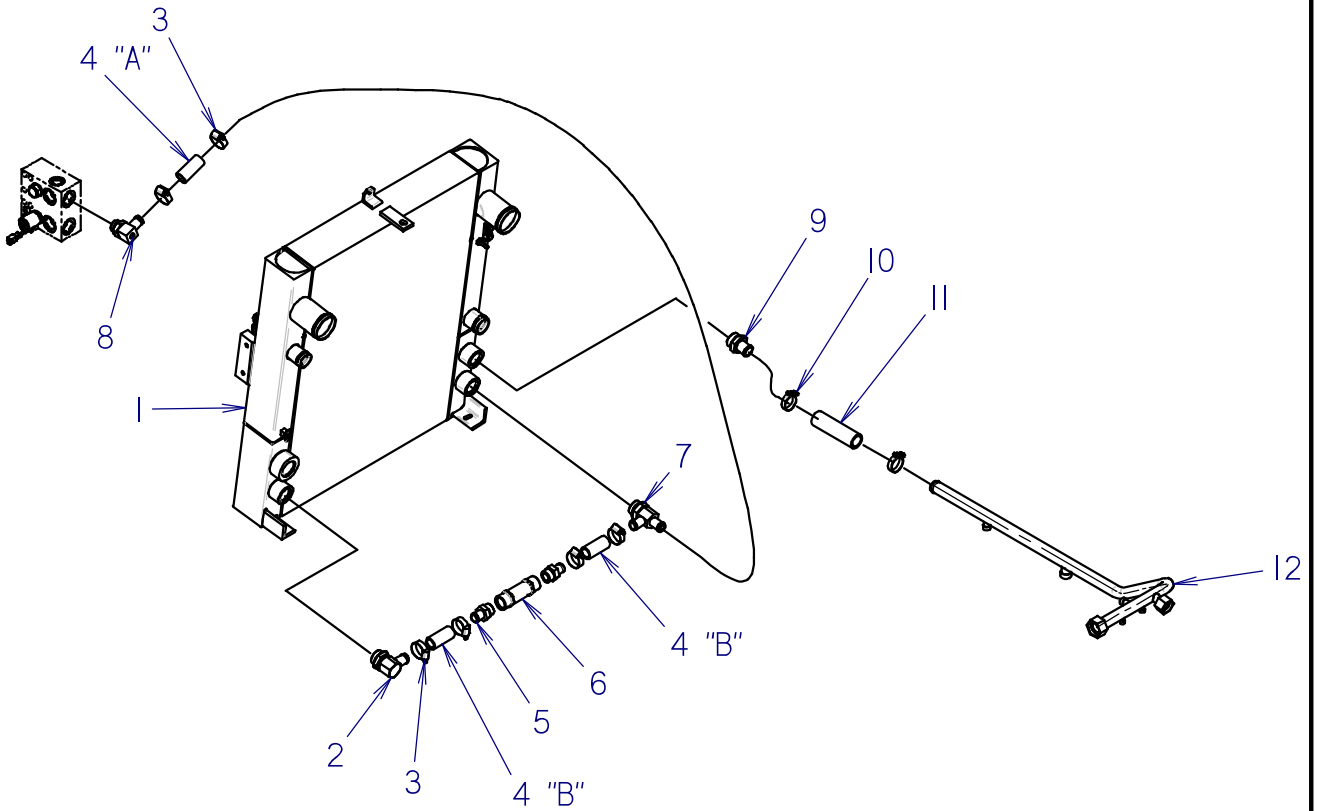

HYDRAULIC OIL COOLER

REF NO.	PART NUMBER	QTY	DESCRIPTION	REMARKS
1	194-841	1	COOLER	
2	155-195	1	S/O COUPLER (20S-16H90)	
3	111-011	6	WORM CLAMP (1" TO 1-3/4")	
4	116-460	102	BULK HOSE (1", SOLD PER FT)	SEE FOOTNOTE 1
5	514-088	2	S/O COUPLER (16S-16H)	
6	153-888	1	CHECK VALVE (16SF-16SF,25 PSI)	
7	150-1172	1	S/O COUPLER (20S-16H-16H)	
8	150-1184	1	CONNECTOR (16S-16H-06SF)	
9	155-004	1	S/O COUPLER (20S-20H)	
10	149-342	2	T-BOLT CLAMP (1.687")	
11	116-587	20	BULK HOSE (1-1/4",SOLD PER FT)	1 @ 20"
12	150-1092	1	HYDRAULIC LINE	

NOT SHOWN:

FOOTNOTES:

- 1. REF. #4 "A" 1@ 80"
- REF #4 "B" 2 @ 11"

NOTE:

HOSE TRACK MOUNT HYDRAULICS

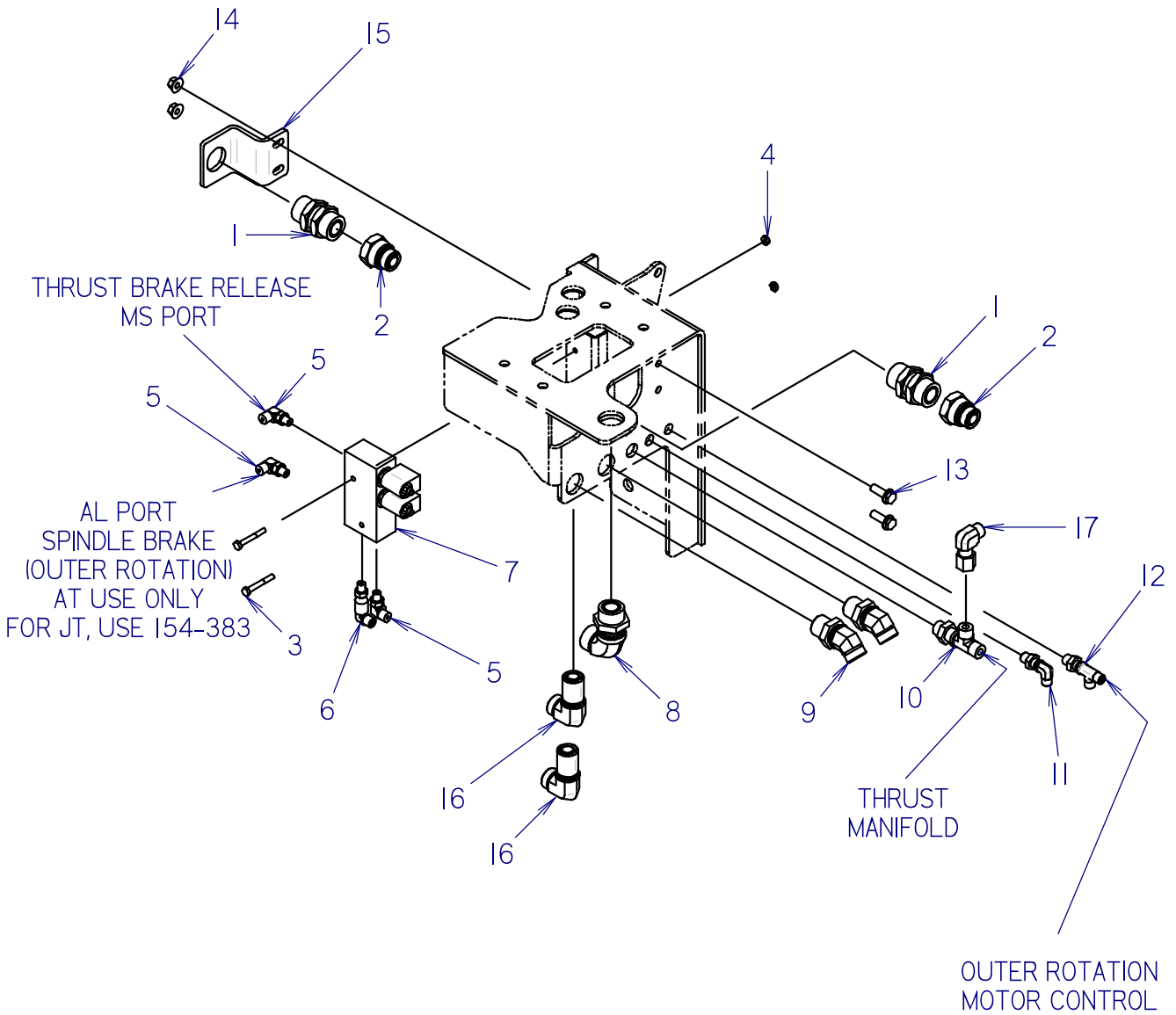

HOSE TRACK MOUNT HYDRAULICS

REF NO.	PART NUMBER	QTY	DESCRIPTION	REMARKS
1	154-389	2	BK CONNECTOR (160-160BK)	
2	154-378	2	REDUCER STEM (120-160F)	
3	105-106	2	BOLT (1/4-NC X 2")	
4	105-085	2	LOCKNUT (1/4"-NC)	
5	154-252	3	CONNECTOR (04S-04090)	
6	154-474	1	CONNECTOR (04S-04090, XL)	
7	157-246	1	MANIFOLD (2-SPI)	
8	154-419	1	BK CONNECTOR (160-16090BK)	
9	154-448	2	BK CONNECTOR (120-12045BK)	
10	154-295	1	BK RUN TEE (080-080-080BK)	
11	154-355	1	BK CONNECTOR (040-04090BK)	
12	154-424	1	BK RUN TEE (040-040-040BK)	
13	106-383	2	FLG LK SCREW (M10-1.50 X 30MM)	
14	106-387	2	FLG LOCKNUT (M10-1.50)	
15	300-1992	1	FORMED BULKHEAD	
16	156-482	2	BK CONNECTOR (120-12090BK)	FOR AT USE ONLY
17	154-256	1	UNION (080-080FX90)	

NOT SHOWN:

154-383 1 PLUG (04S)

FOR JT USE ONLY

FOOTNOTES:

NOTE:

HOSE TRACK HYDRAULICS

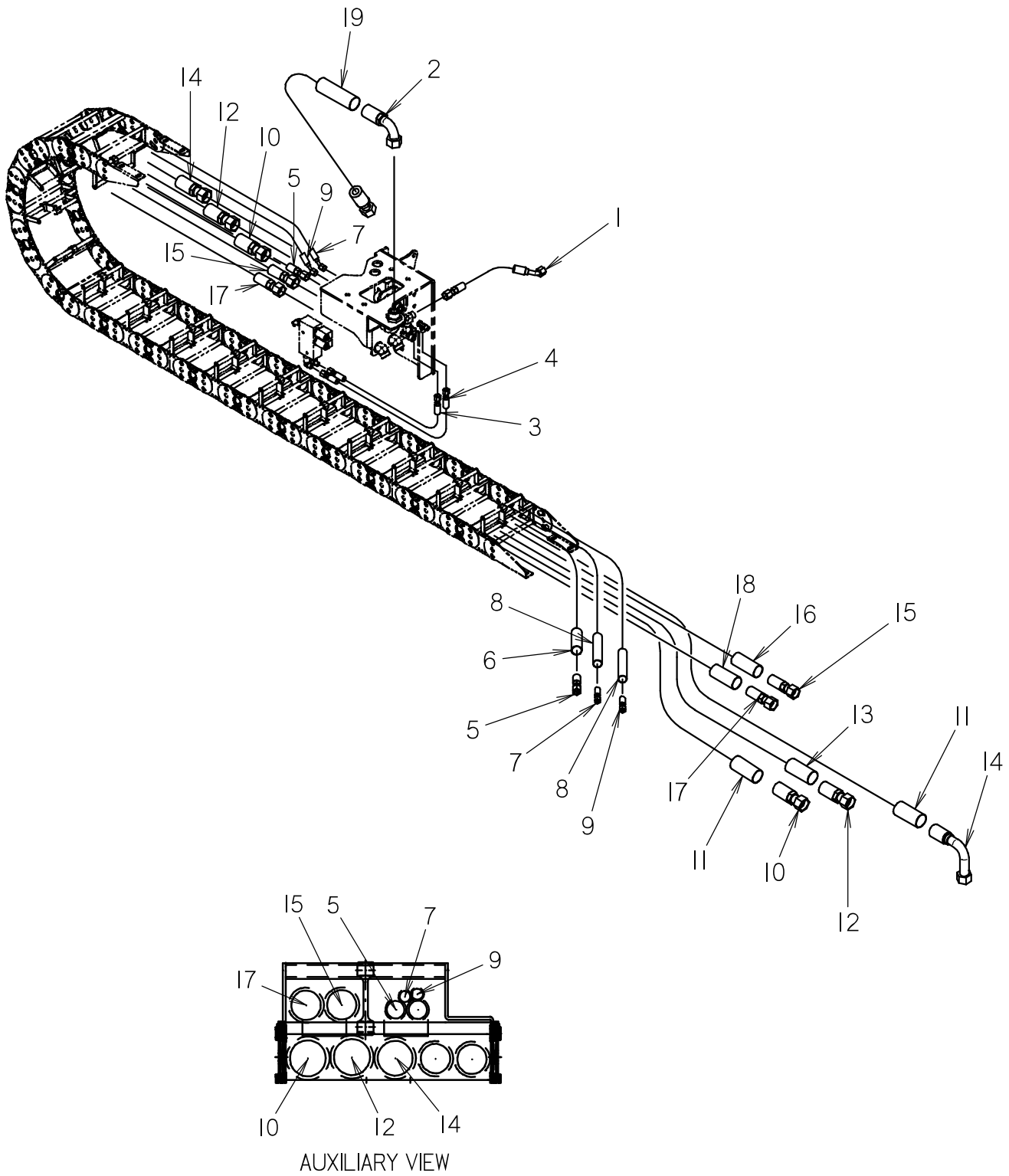

HOSE TRACK HYDRAULICS

REF NO.	PART NUMBER	QTY	DESCRIPTION	REMARKS
1	515-182	1	HOSE I080FX45-14"-3000)	
2	150-1972	1	HOSE I160FX90S-38.5"-3000)	"JT" USE ONLY; USE 150-1670 FOR "AT"
3	154-701	1	HOSE I040FX-14"-3000)	
4	154-672	1	HOSE I040FX-15"-3000)	
5	150-1646	1	HOSE I080FX-153"-3000)	
6	105-1157	1	ABRASION SLEEVE (1.25 X 153")	
7	150-1647	1	HOSE I040FX45-156"-3000)	
8	117-999	2	ABRASION SLEEVE (1.00" X 154")	
9	150-1647	1	HOSE I040FX45-156"-3000)	
10	150-1557	1	HOSE I160FX-183.5"-3000)	
11	105-1153	2	ABRASION SLEEVE (1.75" X 175")	
12	150-1559	1	HOSE I160FX-172"-6000)	
13	105-1154	1	ABRASION SLEEVE (1.75" X 172")	
14	150-1558	1	HOSE I160FX90L-175"-6000)	
15	150-1561	1	HOSE I120FX-158"-5000)	
16	105-1156	1	ABRASION SLEEVE (1.59 X 160")	
17	150-1560	1	HOSE I120FX-160"-5000)	
18	105-1155	1	ABRASION SLEEVE (1.59 X 162")	
19	105-1165	1	ABRASION SLEEVE (1.75" X 40")	

FOOTNOTES:

NOTE:

FROM REFERENCE NUMBERS IN AUXILIARY VIEW ON GRAPHICS PAGE.

- 5. CASE DRAIN
- 7. TANK (CHARGE)
- 9. CHARGE PRESSURE
- 10. DRILL FLUID
- 12. OUTER ROTATION: FWD/MAKE UP
- 14. OUTER ROTATION: REV/BREAK OUT
- 15. THRUST
- 17. PULLBACK

HOSE TRACK HYDRAULICS (AT)

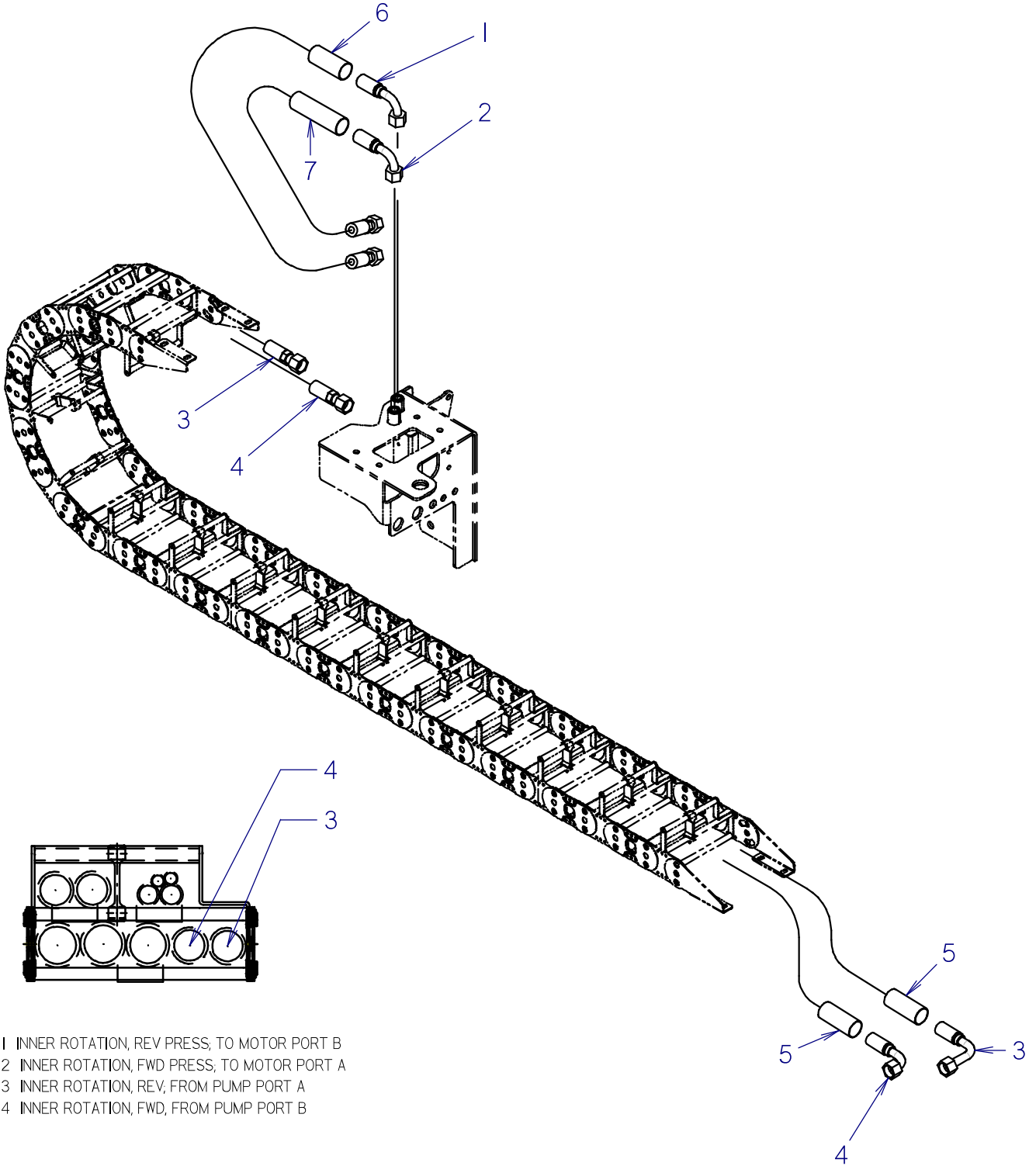

- 1 INNER ROTATION, REV PRESS, TO MOTOR PORT B
- 2 INNER ROTATION, FWD PRESS, TO MOTOR PORT A
- 3 INNER ROTATION, REV, FROM PUMP PORT A
- 4 INNER ROTATION, FWD, FROM PUMP PORT B

HOSE TRACK HYDRAULICS (AT)

REF NO.	PART NUMBER	QTY	DESCRIPTION	REMARKS
1	150-1660	1	HOSE (120FX90S-28"-5000)	
2	150-1661	1	HOSE (12XFX90S-33"-5000)	
3	150-1659	1	HOSE (120FX90L-163"-5000)	
4	150-1658	1	HOSE (120FX90S-161"-5000)	
5	105-1155	2	ABRASION SLEEVE (1.59 X 162")	
6	117-224	1	ABRASION SLEEVE (1.59" X 26")	
7	117-679	1	ABRASION SLEEVE (1.59" X 32")	

NOT SHOWN:

FOOTNOTES:

NOTE:

INNER ROTATION PUMP MOUNT

BEGINS WITH S/N:

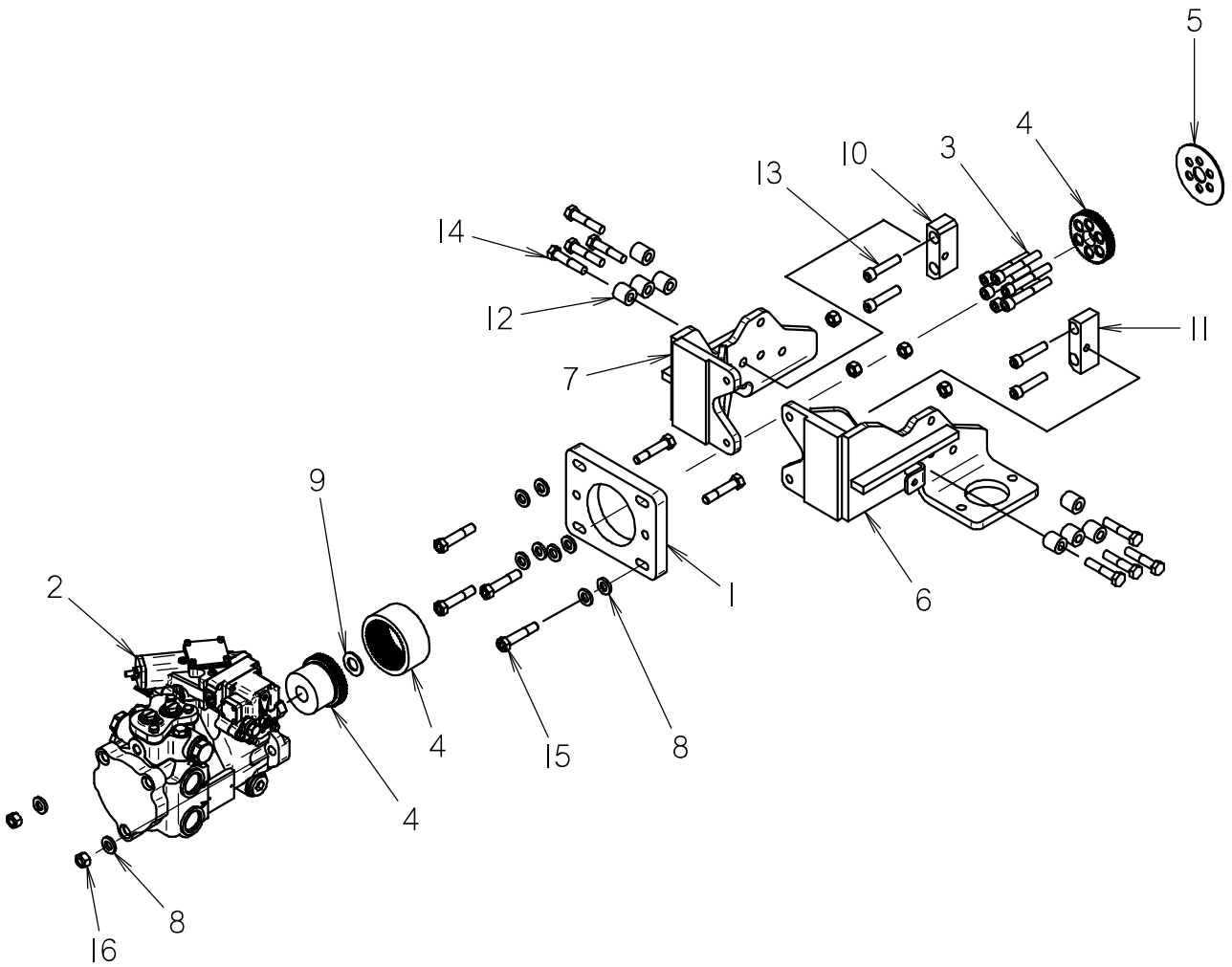

INNER ROTATION PUMP MOUNT BEGINS WITH S/N:

REF NO.	PART NUMBER	QTY	DESCRIPTION	REMARKS
1	300-4112	1	MOUNT PLATE	
2	150-1999	1	HYDRAULIC PUMP	SEE NOT SHOWN PART
3	105-1089	6	SCREW (M12-1.25 X 80MM, SOC, 12.9)	SEE FOOTNOTE 1.
4	166-598	1	PUMP COUPLE	
5	300-4496	1	SPACER	
6	300-4114	1	LEFT MOUNT	
7	300-4113	1	RIGHT MOUNT	
8	106-397	10	WASHER (M12, HARDENED)	
9	106-949	1	WASHER (3/4", HARDENED)	
10	300-6076	1	RIGHT MOUNT BLOCK	
11	300-6077	1	LEFT MOUNT BLOCK	
12	300-4413	8	SPACER	USE AS REQUIRED
13	107-602	4	SCREW (M12-1.75 X 55MM, SOC)	TORQUE TO 90 FT-LBS, USE LOCTITE 242 OR EQUIVALENT
14	106-708	8	SCREW (M12-1.75 X 60MM, 10.9)	TORQUE TO 120 FT-LBS, USE LOCTITE 242 OR EQUIVALENT
15	106-197	6	BOLT (1/2-NC X 2-1/2", GD8)	TORQUE TO 80 FT-LBS
16	105-065	6	LOCKNUT (1/2-NC)	TORQUE TO 80 FT-LBS

NOT SHOWN:

105-410	CASTLE NUT (3/4 NF)	TORQUE TO 125 FT-LBS, USE LOCTITE 242 OR EQUIVALENT
190-1298	PUMP ALIGNMENT TOOL KIT	
260-1064	BARRING TOOL	
165-977	WOODRUFF KEY (1/4"X7/8")	USED ON TAPERED SHAFT
500-806	SEAL KIT	

FOOTNOTES:

- I. LUBRICATE BOLTS WITH CLEAN OIL
 - STEP 1: TORQUE TO 37 FT-LBS
 - STEP 2: ROTATE 90°

NOTE:

INNER ROTATION PUMP HYDRAULICS

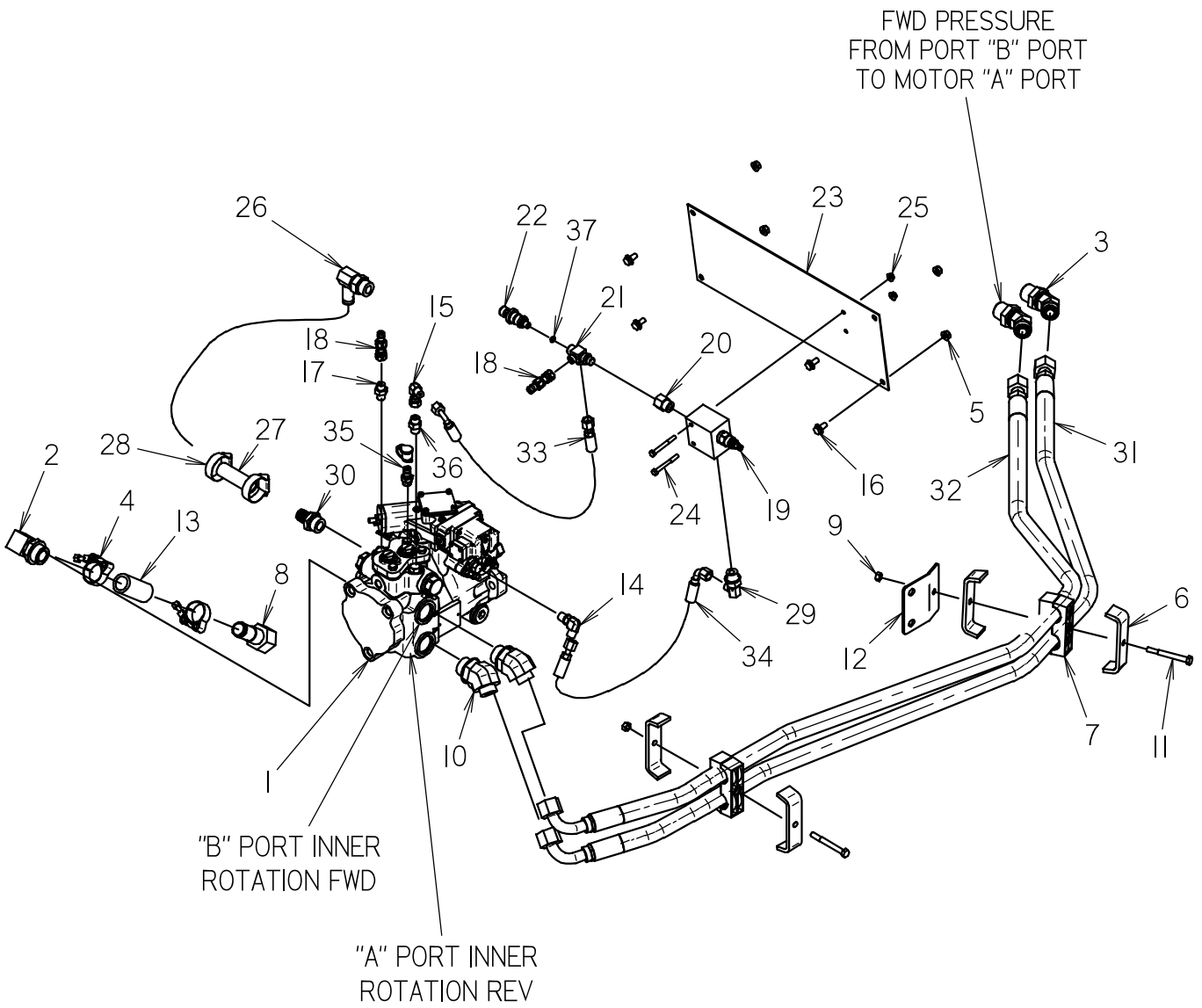

INNER ROTATION PUMP HYDRAULICS

REF NO.	PART NUMBER	QTY	DESCRIPTION	REMARKS
1	150-1999	1	HYDRAULIC PUMP	SEE FOOTNOTE 1
2	154-188	1	S/O COUPLER (16S-16H90)	
3	154-448	2	BK CONNECTOR (120-12045BK)	
4	111-027	2	T-BOLT CLAMP (1.25" - 1.50")	
5	106-386	4	FLG LOCKNUT (M8-1.25)	
6	315-623	4	CLAMP BAR	
7	110-274	2	BOLT-ON CLAMP (1-1/4" PER SET)	
8	150-1236	1	S/O COUPLER (16FO-16H)	
9	106-561	2	LOCKNUT (M8-1.25, PRV TRQ, 10.9)	
10	154-358	2	CONNECTOR (120-16S45)	
11	106-602	2	SCREW (M8-1.25 X 80MM)	
12	300-1957	1	BRACKET	
13	116-460	18	BULK HOSE (1", SOLD PER FT)	1 @ 18"
14	154-226	1	CONNECTOR (040-06S90)	
15	154-255	1	UNION (040-040FX90)	
16	107-095	4	FLG SCREW (M8-1.25 X 16MM)	
17	154-220	1	CONNECTOR (040-06S)	
18	159-156	2	QDC ADAPTER (02-040F)	
19	150-3182	1	HYDRAULIC RELIEF VALVE	
20	155-163	1	REDUCER (08S-06SF)	
21	150-1150	1	CONNECTOR (06S-04SF-040-040)	
22	214-569	1	PRESSURE TRANSDUCER (6000 PSI)	
23	300-3030	1	COVER PLATE	FOR "AT" USE ONLY; USE 300-1221 FOR "JT" USE
24	106-893	2	SCREW (M6-1.00 X 55MM)	
25	106-385	2	FLG LOCKNUT (M6-1.00)	
26	155-174	1	S/O COUPLER (12S-12H90)	
27	116-636	29	BULK HOSE (3/4", SOLD PER FT)	1 @ 29"
28	111-011	2	WORM CLAMP (1" TO 1-3/4")	
29	154-276	1	CONNECTOR (040-08S90)	
30	155-046	1	S/O COUPLER (12S-12H)	
31	150-1115	1	HOSE (120FX90-84"-5000)	
32	150-2264	1	HOSE (120FX90-82"-5000)	
33	515-340	1	HOSE (040FX90-18"-5000)	
34	515-340	1	HOSE (040FX90-18"-5000)	
35	159-147	1	QDC ADAPTER (02-06S)	SEE FOOTNOTE 2
36	514-018	1	CONNECTOR (040-06S, ORF)	
37	155-760	1	O-RING (904 D90)	

NOT SHOWN:

FOOTNOTES:

- | | | |
|------------|-------------------------------|---------------|
| 1. 157-568 | SHAFT SEAL | |
| 152-173 | HYD RELIEF VALVE | 5000 PSI |
| 500-1430 | RELIEF VALVE | 4350 PSI |
| 217-258 | ELECTRIC DISPLACEMENT CONTROL | |
| 190-1015 | SHIM KIT | CHARGE RELIEF |
| 150-1020 | SPRING, RELIEF | CHARGE RELIEF |
| 500-806 | SEAL KIT | |
| 2. 159-148 | DUST CAP | |

NOTE:

INNER ROTATION HYDRAULICS

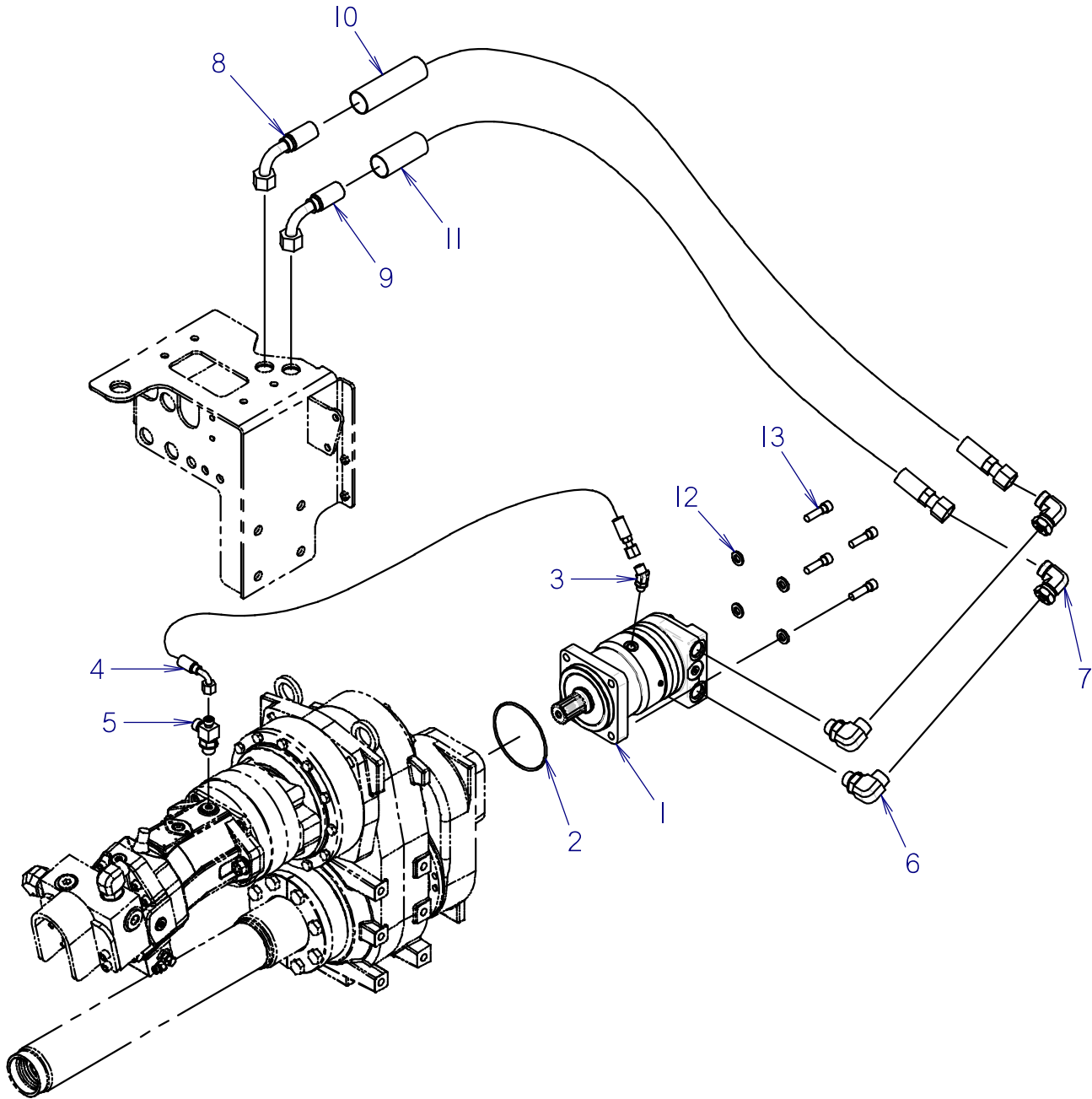

INNER ROTATION HYDRAULICS

REF NO.	PART NUMBER	QTY	DESCRIPTION	REMARKS
1	I58-208	1	HYDRAULIC MOTOR	SEAL KIT I50-I04I
2	I55-770	1	O-RING (250 D70)	
3	I54-224	1	CONNECTOR (06S-06045)	
4	I50-I669	1	HOSE (060FX90S-32"-3000)	
5	I59-801	1	RUN TEE (10S-060-080)	
6	I54-270	2	CONNECTOR (12S-I2090)	
7	I54-457	2	UNION (120-I20FX90)	
8	I50-I661	1	HOSE (12FX90S-33"-5000)	
9	I50-I660	1	HOSE (120FX90S-28"-5000)	
10	117-679	1	ABRASION SLEEVE (1.59" X 32")	
11	117-224	1	ABRASION SLEEVE (1.59" X 26")	
12	106-397	4	WASHER (M12, HARDENED)	
13	106-707	4	SCREW (M12-1.75 X 45MM, SOC)	

NOT SHOWN:

FOOTNOTES:

NOTE:

P.O.R. MANIFOLD (AT)
ENDS WITH S/N: CMWJ30ATCB0000319

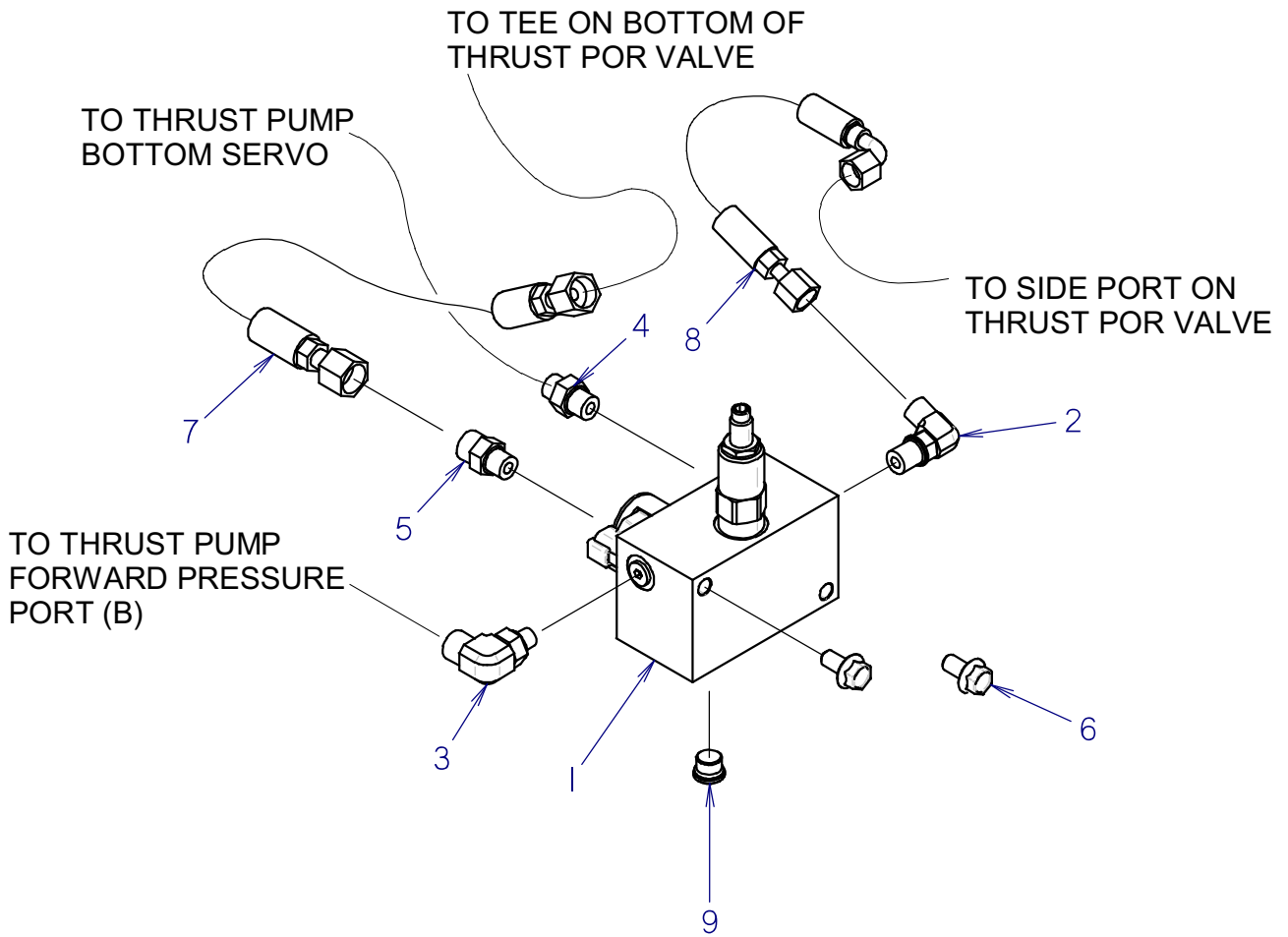

P.O.R. MANIFOLD (AT)
ENDS WITH S/N: CMWJ30ATCB0000319

REF NO.	PART NUMBER	QTY	DESCRIPTION	REMARKS
1	150-1058	1	POR MANIFOLD	SEE FOOTNOTE 1
2	154-226	1	CONNECTOR (040-06S90)	
3	514-049	1	CONNECTOR (04S-06090)	
4	154-220	1	CONNECTOR (040-06S)	
5	154-221	1	CONNECTOR (06S-060)	
6	105-825	2	FLG LK BOLT (3/8-NC X 3/4)	
7	150-1552	1	HOSE (060FX-22"-5000)	
8	515-148	1	HOSE (040FX90-10"-3000)	
9	154-384	1	PLUG (06S)	

NOT SHOWN:

FOOTNOTES:

- 1. 150-1876 RELIEF VALVE
- 500-1415 SEAL REPAIR KIT FOR USE ON 150-1876
- 150-1875 SOLENOID VALVE, 2W2P
- 500-1311 SOLENOID COIL, 12VDC WIZENER DIODE FOR USE ON 150-1875
- 500-1414 SEAL REPAIR KIT FOR USE ON 150-1875

NOTE:

PUMP MOUNT

ENDS WITH S/N: JT-CMW30M1C80000131, AT-CMWJ30ATC80000062

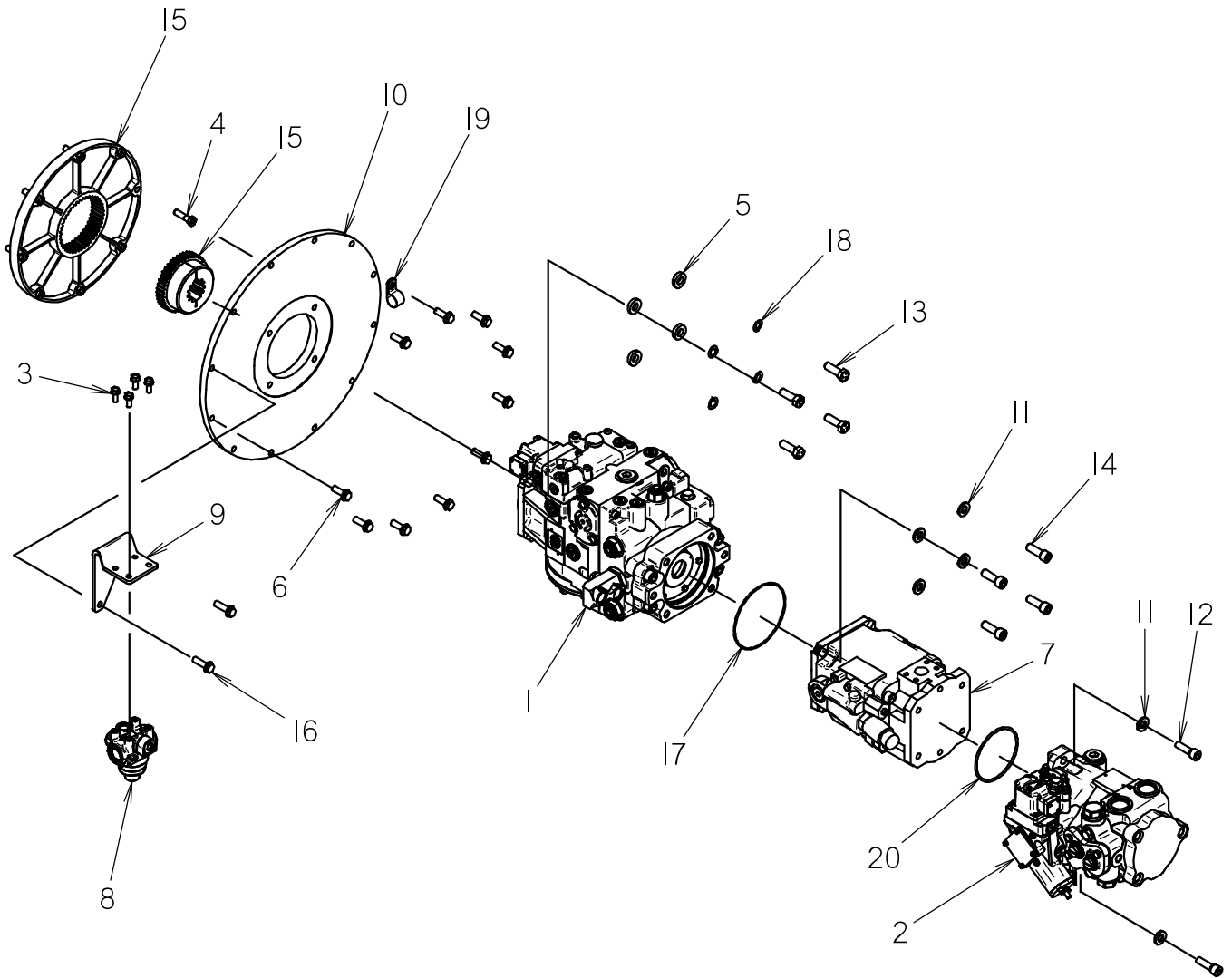

PUMP MOUNT

ENDS WITH S/N: JT-CMW30M1C80000131, AT-CMWJ30ATC80000062

REF NO.	PART NUMBER	QTY	DESCRIPTION	REMARKS
1	153-105	1	PUMP, HYDRAULIC	
2	158-224	1	HYDRAULIC PUMP	
3	105-823	4	FLG LK BOLT (5/16-NC X 3/4")	USE LOCTITE 242 OR EQUIVALENT
4	105-156	8	BOLT (3/8-NC X 1-1/2")	USE LOCTITE 242 OR EQUIVALENT, TORQUE TO 40 FT-LBS
5	105-244	4	WASHER	
6	106-164	10	FLG LK SCREW (M10-1.50 X 30MM)	USE LOCTITE 242 OR EQUIVALENT, TORQUE TO 25 FT-LBS
7	150-1489	1	PUMP, ELECTRIC CONTROL (63CC)	
8	153-050	1	FILTER HEAD (12 SF)	
9	300-1171	1	FILTER BRACKET	
10	336-051	1	FLYWHEEL HOUSING COVER	
11	106-397	6	WASHER (M12, HARDENED)	
12	107-044	2	SCREW (M12-1.75 X 40MM, SOC)	
13	105-048	4	BOLT (1/2-NC X 1-1/2")	
14	106-204	4	BOLT (1/2 - NC X 1.50", SOC)	
15	160-914	1	PUMP COUPLE	TORQUE CROSS BOLT TO 61 FT-LBS
16	107-643	2	FLG LK SCREW (M10-1.50 X 35MM)	USE LOCTITE 242 OR EQUIVALENT, TORQUE TO 25 FT-LBS
17	157-084	1	O-RING (159 D70)	
18	105-070	4	LOCK WASHER (1/2")	
19	110-333	1	BOLT-ON CLAMP (1")	
20	105-1249	1	O-RING (242 D70)	

NOT SHOWN:

FOOTNOTES:

NOTE:

PUMP MOUNT

BEGINS WITH S/N: JT-CMWJ30M1T80000132, AT-CMWJ30ATV80000063

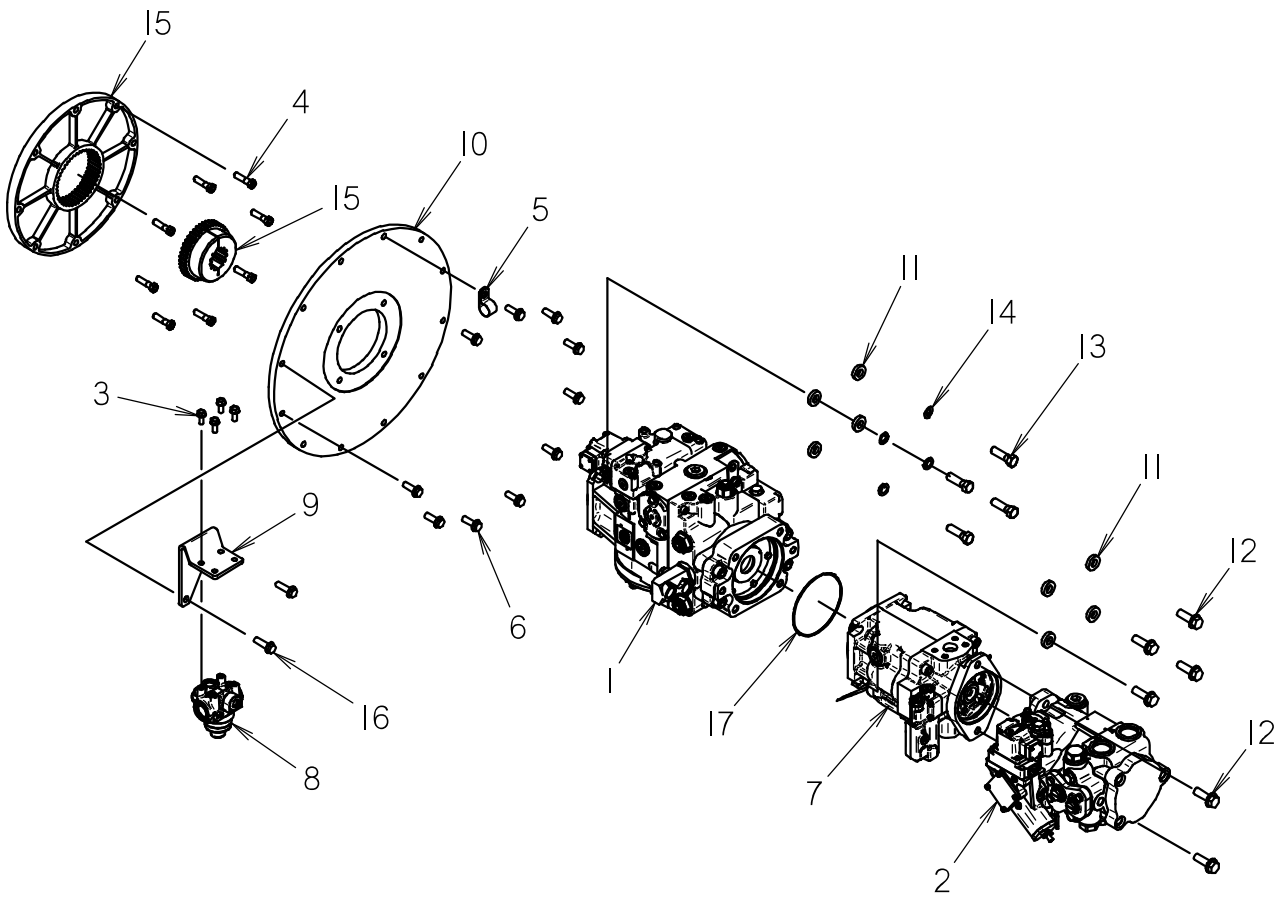

PUMP MOUNT

BEGINS WITH S/N: JT-CMWJ30M1T80000132, AT-CMWJ30ATV80000063

REF NO.	PART NUMBER	QTY	DESCRIPTION	REMARKS
1	153-105	1	PUMP, HYDRAULIC	
2	158-224	1	HYDRAULIC PUMP	
3	105-823	4	FLG LK BOLT (5/16-NC X 3/4")	USE LOCTITE 242 OR EQUIVALENT
4	105-156	8	BOLT (3/8-NC X 1-1/2")	USE LOCTITE 242 OR EQUIVALENT, TORQUE TO 40 FT-LBS
5	110-333	1	BOLT-ON CLAMP (1")	
6	106-164	10	FLG LK SCREW (M10-1.50 X 30MM)	USE LOCTITE 242 OR EQUIVALENT, TORQUE TO 25 FT-LBS
7	150-2113	1	LOAD SENSE PISTON PUMP, 60CC	SEE FOOTNOTE 1 FOR SERVICE PARTS
8	153-050	1	FILTER HEAD (12 SF)	
9	300-1171	1	FILTER BRACKET	
10	336-051	1	FLYWHEEL HOUSING COVER	
11	105-244	8	WASHER	
12	105-831	6	FLG LK BOLT (1/2-NC X 1-1/2")	
13	105-066	4	BOLT (1/2-NC X 1-3/4")	
14	105-070	4	LOCK WASHER (1/2")	
15	160-914	1	PUMP COUPLE	TORQUE CROSS BOLT TO 61 FT-LBS
16	106-497	2	FLG SCREW (M10-1.50 X 35MM)	USE LOCTITE 242 OR EQUIVALENT, TORQUE TO 25 FT-LBS
17	157-1001	1	O-RING (2-158 D75)	

NOT SHOWN:

FOOTNOTES:

- I. 155-800 O-RING (045 D70); THROUGH DRIVE PILOT O-RING

NOTE:

PUMP STACK SUCTION

ENDS WITH S/N: JT-CMW30M1C80000131, AT-CMWJ30ATC80000062

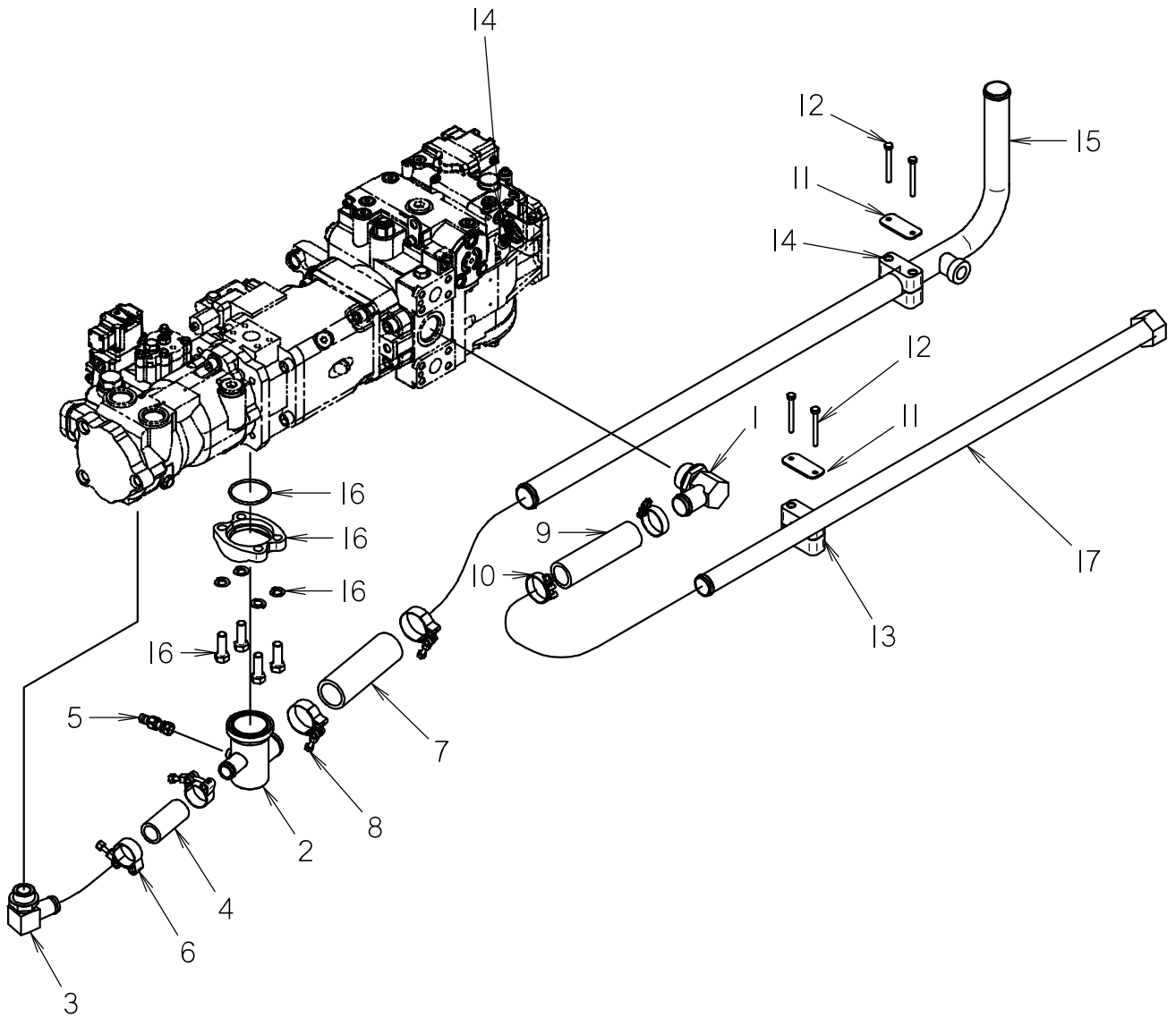

PUMP STACK SUCTION

ENDS WITH S/N: JT-CMW30M1C80000131, AT-CMWJ30ATC80000062

REF NO.	PART NUMBER	QTY	DESCRIPTION	REMARKS
1	155-168	1	S/O COUPLER (20S-20H90)	
2	105-1016	1	SUCTION FLANGE/FITTING	
3	154-188	1	S/O COUPLER (16S-16H90)	
4	116-460	9	BULK HOSE (1", SOLD PER FT)	1 @ 9"
5	159-156	1	QDC ADAPTER (02-040F)	
6	111-027	2	T-BOLT CLAMP (1.25" - 1.50")	
7	116-588	25	BULK HOSE (1-1/2",SOLD PER FT)	1 @ 25"
8	111-028	2	T-BOLT CLAMP (1.75"-2.00")	
9	116-587	28	BULK HOSE (1-1/4",SOLD PER FT)	1 @ 28"
10	149-342	2	T-BOLT CLAMP (1.687")	
11	322-362	3	BACKUP SPACER	
12	105-224	6	BOLT (1/4-NC X 2-1/2")	
13	111-026	1	BOLT-ON CLAMP (1-1/4", PAIR)	
14	111-008	2	BOLT-ON CLAMP (1-1/2", SET)	
15	150-1091	1	HYDRAULIC LINE	
16	514-104	1	SPLIT FLANGE (32SF)	
17	150-1090	1	HYDRAULIC LINE	

NOT SHOWN:

FOOTNOTES:

NOTE:

PUMP STACK SUCTION

BEGINS WITH S/N: JT-CMWJ30M1T80000132, AT-CMWJ30ATV80000063

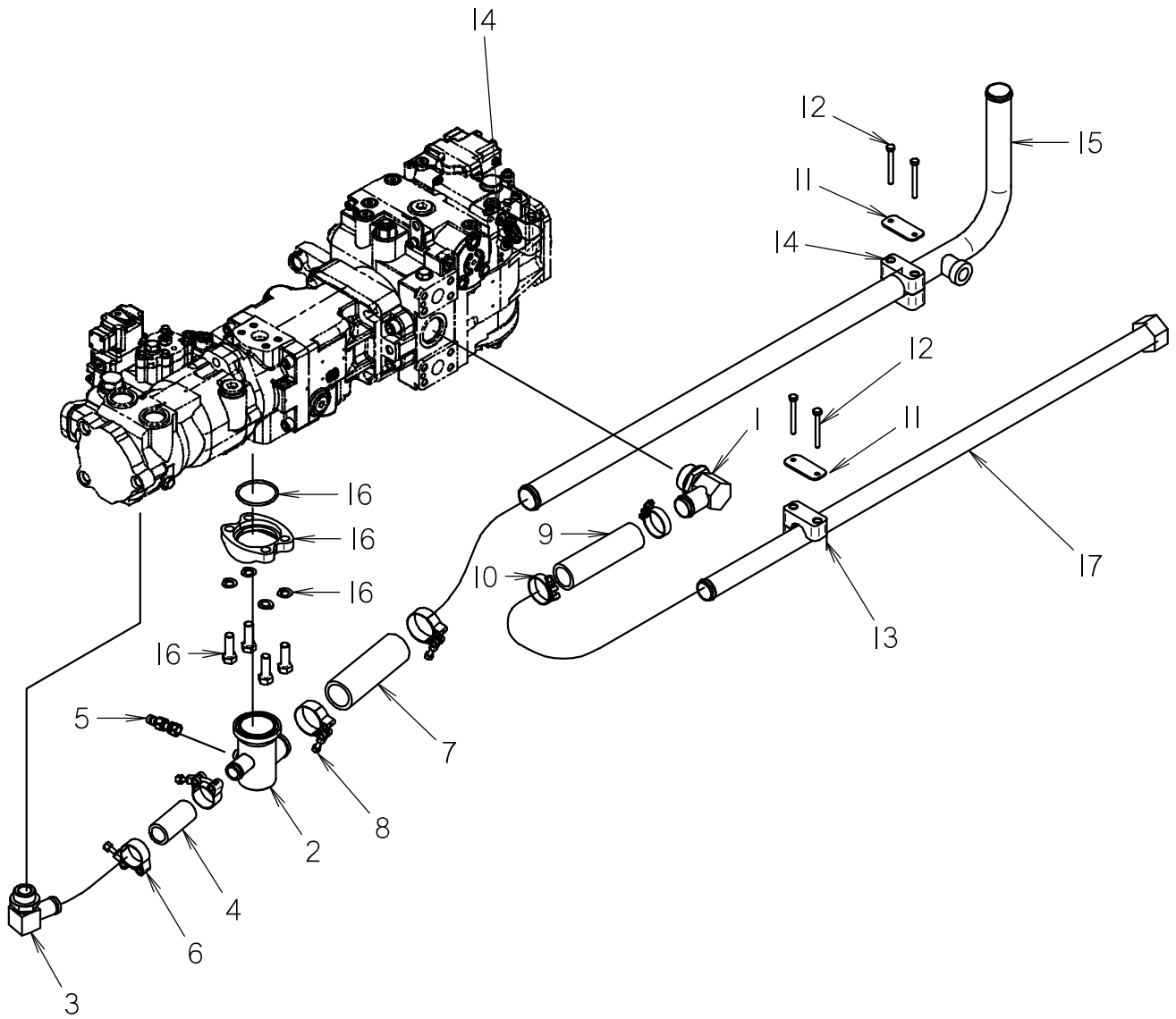

PUMP STACK SUCTION

BEGINS WITH S/N: JT-CMWJ30M1T80000132, AT-CMWJ30ATV80000063

REF NO.	PART NUMBER	QTY	DESCRIPTION	REMARKS
1	155-168	1	S/O COUPLER (20S-20H90)	
2	105-1016	1	SUCTION FLANGE/FITTING	
3	154-188	1	S/O COUPLER (16S-16H90)	
4	116-460	10	BULK HOSE (1", SOLD PER FT)	1 @ 10"
5	159-156	1	QDC ADAPTER (02-040F)	
6	111-027	2	T-BOLT CLAMP (1.25" - 1.50")	
7	116-588	26	BULK HOSE (1-1/2",SOLD PER FT)	1 @ 26"
8	111-028	2	T-BOLT CLAMP (1.75"-2.00")	
9	116-587	28	BULK HOSE (1-1/4",SOLD PER FT)	1 @ 28"
10	149-342	2	T-BOLT CLAMP (1.687")	
11	322-362	3	BACKUP SPACER	
12	105-224	6	BOLT (1/4-NC X 2-1/2")	
13	111-026	1	BOLT-ON CLAMP (1-1/4", PAIR)	
14	111-008	2	BOLT-ON CLAMP (1-1/2", SET)	
15	150-1091	1	HYDRAULIC LINE	
16	514-104	1	SPLIT FLANGE (32SF)	
17	150-1090	1	HYDRAULIC LINE	

NOT SHOWN:

FOOTNOTES:

NOTE:

PUMP STACK POR HYDRAULICS

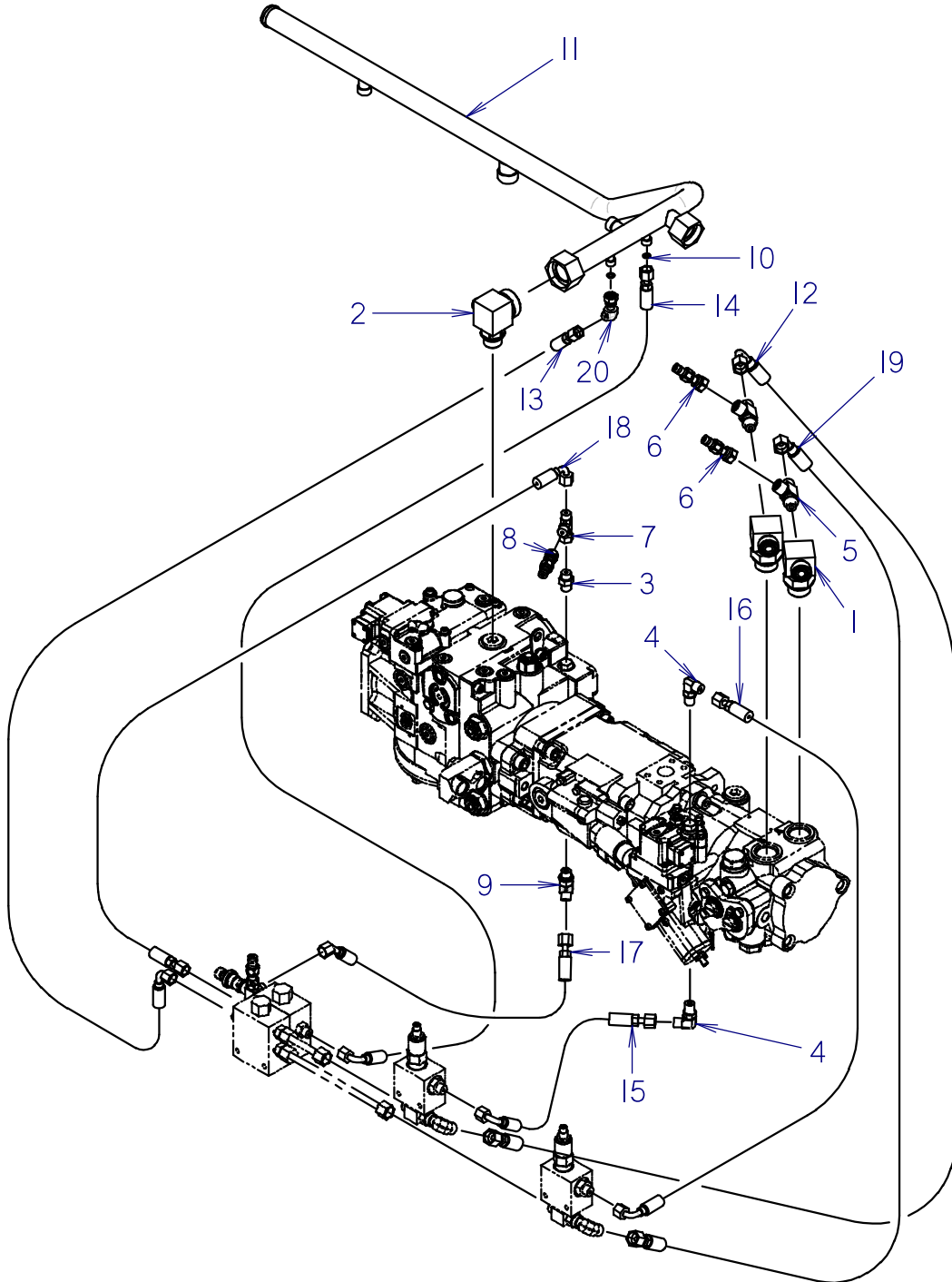

PUMP STACK POR HYDRAULICS

REF NO.	PART NUMBER	QTY	DESCRIPTION	REMARKS
1	150-1223	2	CONNECTOR (16S-120-06SF 90)	
2	157-768	1	CONNECTOR (12S-200-060)	
3	154-220	1	CONNECTOR (040-06S)	
4	154-226	2	CONNECTOR (040-06S90)	
5	154-345	2	RUN TEE (06S-060-060)	
6	159-157	2	QDC ADAPTER (02-060F)	
7	154-265	1	UNION RUN TEE (040FX-040-040)	
8	159-156	1	QDC ADAPTER (02-040F)	
9	154-250	1	CONNECTOR (040-06S45)	
10	157-037	2	O-RING (011 D90)	
11	150-1092	1	HYDRAULIC LINE	
12	150-1987	1	HOSE (060FX90M-31"-5000)	
13	515-010	1	HOSE (040FX90-32"-3000)	
14	515-010	1	HOSE (040FX90-32"-3000)	
15	515-148	1	HOSE (040FX90-10"-3000)	
16	154-743	1	HOSE (040FX90-23"-3000)	
17	150-1873	1	HOSE (040FX45-16"-6000)	
18	150-1872	1	HOSE (040FX90-26"-6000)	
19	150-1550	1	HOSE (060FX90-27"-5000)	
20	150-1959	1	CONNECTOR (040-040FX45)	

NOT SHOWN:

FOOTNOTES:

NOTE:

PUMP STACK RETURN

ENDS WITH S/N: JT-CMW30M1C80000131, AT-CMWJ30ATC80000062

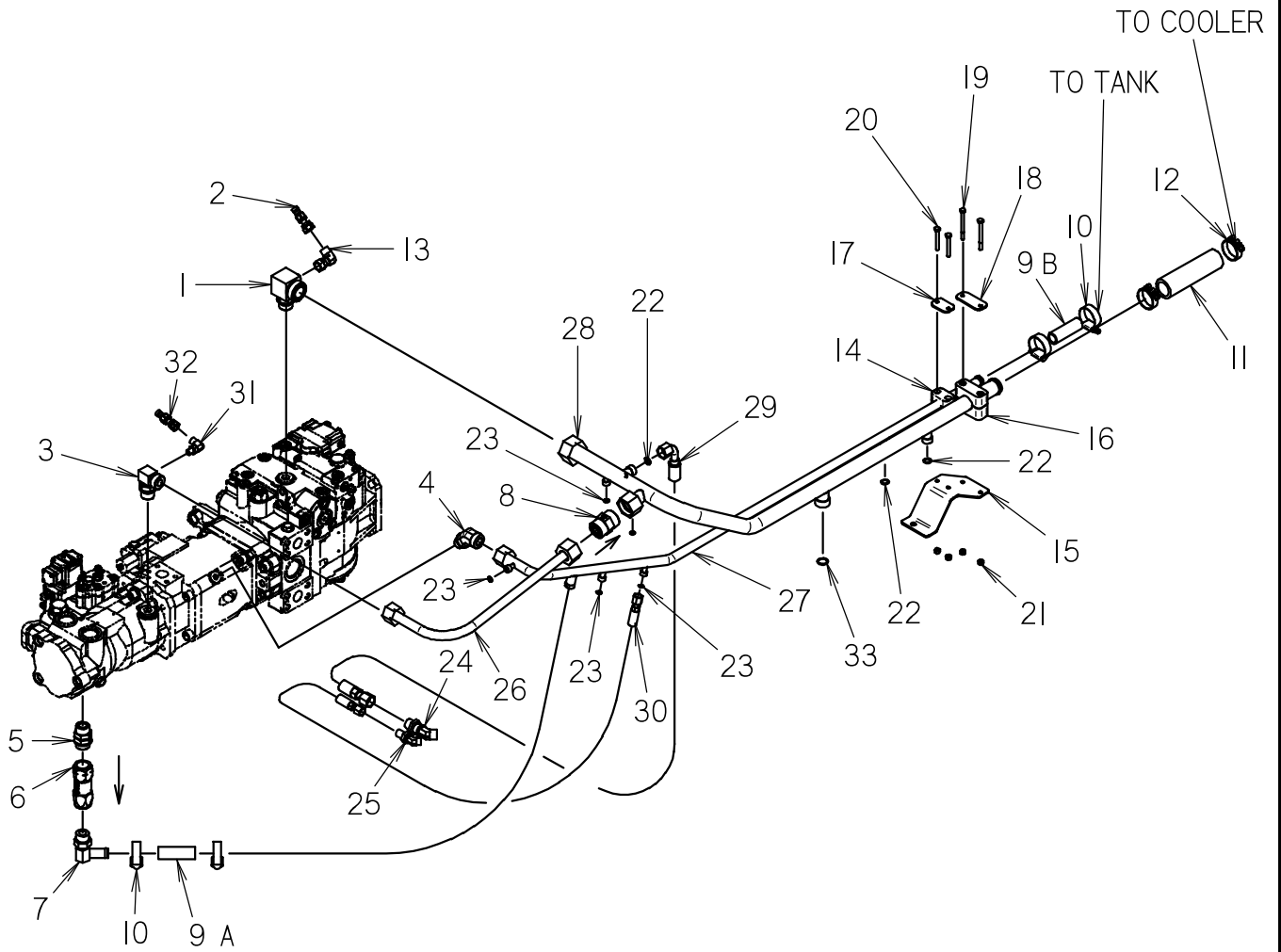

PUMP STACK RETURN

ENDS WITH S/N: JT-CMW30M1C80000131, AT-CMWJ30ATC80000062

REF NO.	PART NUMBER	QTY	DESCRIPTION	REMARKS
1	157-768	1	CONNECTOR (12S-200-060)	
2	159-157	1	QDC ADAPTER (02-060F)	
3	154-500	1	CONNECTOR (12S-12090, 04SF)	
4	154-336	1	CONNECTOR (10S-12045)	
5	155-152	1	CONNECTOR (12S-12S)	
6	155-245	1	CHECK VALVE (12SF-12SF)	
7	155-174	1	S/O COUPLER (12S-12H90)	
8	153-904	1	CHECK VALVE	
9	116-636	47	BULK HOSE (3/4", SOLD PER FT)	A = 1 @ 22"; B = 1 @ 25"
10	111-011	4	WORM CLAMP (1" TO 1-3/4")	
11	116-587	20	BULK HOSE (1-1/4",SOLD PER FT)	1 @ 20"
12	149-342	2	T-BOLT CLAMP (1.687")	
13	154-228	1	UNION (060-060FX90)	
14	110-411	1	BOLT-ON CLAMP (3/4", SET)	
15	300-1628	1	BRACKET	
16	111-026	1	BOLT-ON CLAMP (1-1/4", PAIR)	
17	322-289	1	BACKUP (BOLT-ON)	
18	322-362	1	BACKUP SPACER	
19	106-566	2	SCREW (M6-1.00 X 70MM)	
20	107-025	2	SCREW (M6-1.00 X 50MM)	
21	106-538	4	LOCKNUT (M6-1.00,PRV TRQ,10,9)	
22	157-039	3	O-RING (014 D90)	
23	157-037	5	O-RING (011 D90)	
24	154-393	1	BK CONNECTOR (080-08045BK)	
25	154-285	1	BK CONNECTOR (040-04045BK)	
26	150-1098	1	HYDRAULIC LINE	
27	150-1095	1	HYDRAULIC LINE	
28	150-1092	1	HYDRAULIC LINE	
29	154-833	1	HOSE (080FX90-24"-3000)	
30	155-484	1	HOSE (040FX-16"-3000)	
31	154-252	1	CONNECTOR (04S-04090)	
32	159-156	1	QDC ADAPTER (02-040F)	
33	157-017	1	O-RING (018 D90)	

NOT SHOWN:

FOOTNOTES:

NOTE:

PUMP STACK RETURN

BEGINS WITH S/N: JT-CMWJ30M1T80000132, AT-CMWJ30ATV80000063

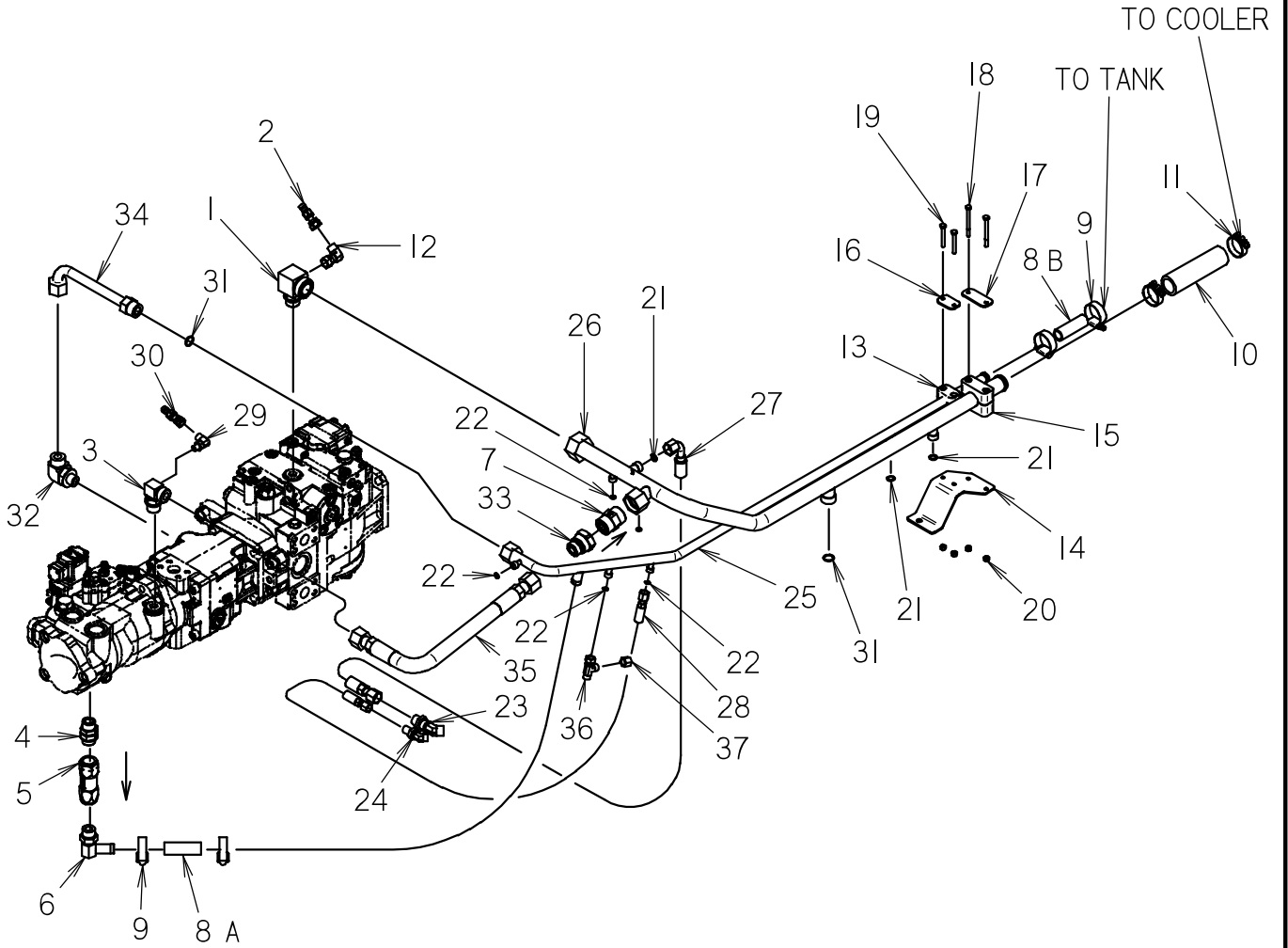

PUMP STACK RETURN

BEGINS WITH S/N: JT-CMWJ30M1T80000132, AT-CMWJ30ATV80000063

REF NO.	PART NUMBER	QTY	DESCRIPTION	REMARKS
1	157-768	1	CONNECTOR (12S-200-060)	
2	159-157	1	QDC ADAPTER (02-060F)	
3	154-500	1	CONNECTOR (12S-12090, 04SF)	
4	155-152	1	CONNECTOR (12S-12S)	
5	155-245	1	CHECK VALVE (12SF-12SF)	
6	155-174	1	S/O COUPLER (12S-12H90)	
7	153-904	1	CHECK VALVE	
8	116-636	51	BULK HOSE (3/4", SOLD PER FT)	A = 1 @ 26" B = 1 @ 25"
9	111-011	4	WORM CLAMP (1" TO 1-3/4")	
10	116-587	20	BULK HOSE (1-1/4",SOLD PER FT)	1 @ 20"
11	149-342	2	T-BOLT CLAMP (1.687")	
12	154-228	1	UNION (060-060FX90)	
13	110-411	1	BOLT-ON CLAMP (3/4", SET)	
14	300-1628	1	BRACKET	
15	111-026	1	BOLT-ON CLAMP (1-1/4", PAIR)	
16	322-289	1	BACKUP (BOLT-ON)	
17	322-362	1	BACKUP SPACER	
18	106-566	2	SCREW (M6-1.00 X 70MM)	
19	107-025	2	SCREW (M6-1.00 X 50MM)	
20	106-538	4	LOCKNUT (M6-1.00,PRV TRQ,10.9)	
21	157-039	3	O-RING (014 D90)	
22	157-037	5	O-RING (011 D90)	
23	154-393	1	BK CONNECTOR (080-08045BK)	
24	154-285	1	BK CONNECTOR (040-04045BK)	
25	150-1095	1	HYDRAULIC LINE	
26	150-1092	1	HYDRAULIC LINE	
27	154-833	1	HOSE (080FX90-24"-3000)	
28	155-484	1	HOSE (040FX-16"-3000)	
29	154-252	1	CONNECTOR (04S-04090)	
30	159-156	1	QDC ADAPTER (02-040F)	
31	157-017	2	O-RING (018 D90)	
32	154-273	1	CONNECTOR (10S-12090)	
33	154-378	1	REDUCER STEM (120-160F)	
34	150-2136	1	HYDRAULIC LINE (-12)	
35	150-2134	1	HOSE (120FX-16"-3000)	
36	154-265	1	UNION RUN TEE (040FX-040-040)	
37	154-296	1	CAP (040F)	

NOT SHOWN:

FOOTNOTES:

NOTE:

OUTER ROTATION PUMP HYDRAULICS

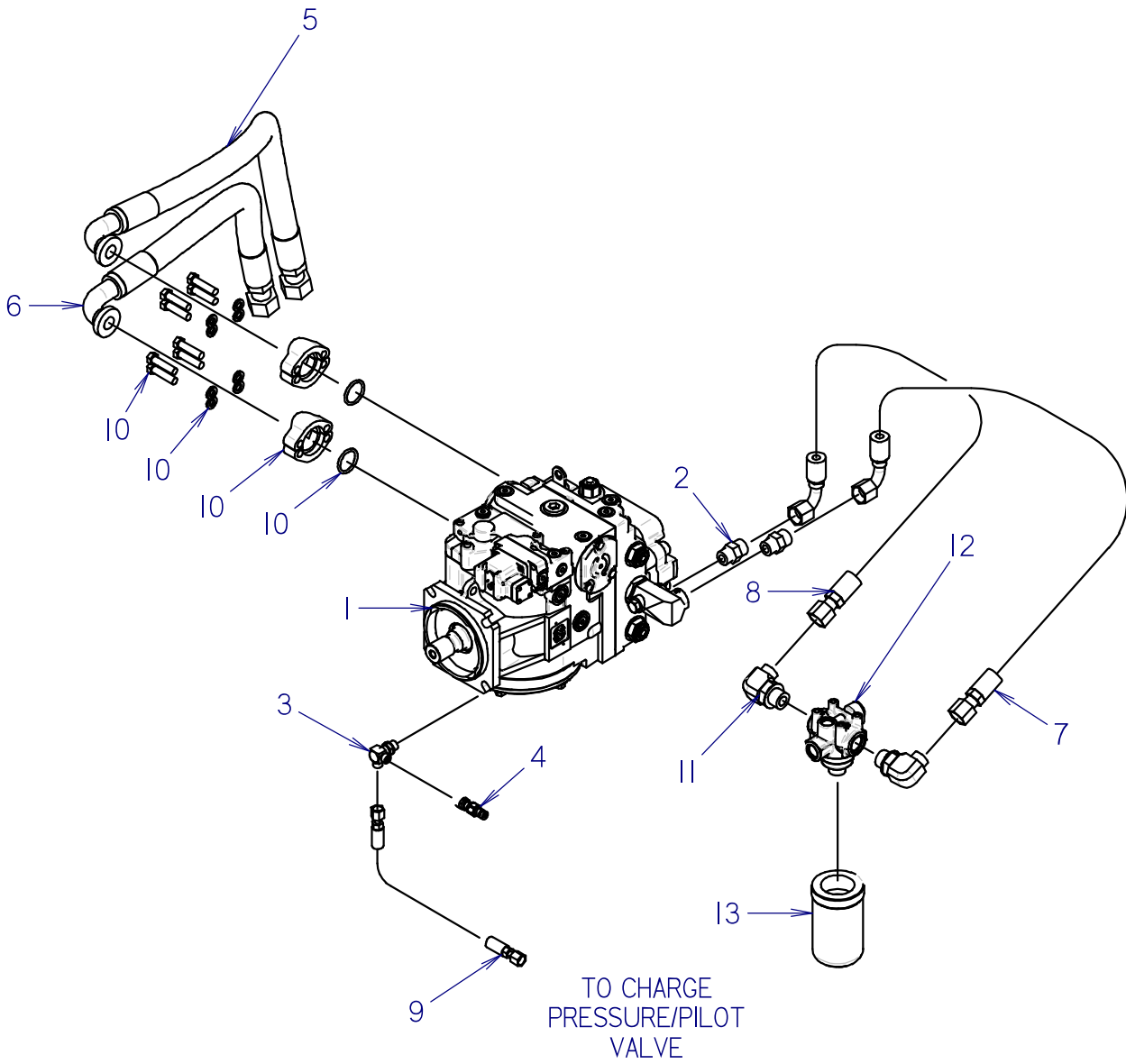

TO CHARGE
PRESSURE/PILOT
VALVE

OUTER ROTATION PUMP HYDRAULICS

REF NO.	PART NUMBER	QTY	DESCRIPTION	REMARKS
1	153-105	1	PUMP, HYDRAULIC	SEE FOOTNOTE 1 FOR SERVICE PARTS
2	154-301	2	CONNECTOR (10S-100)	
3	154-230	1	BRANCH TEE (06S-040-040)	
4	159-156	1	QDC ADAPTER (02-040F)	
5	150-1111	1	HOSE (16FL90-160FX-38"-6000)	
6	150-1112	1	HOSE (16FL90L-160FX-35"-6000)	
7	153-267	1	HOSE (100FX90S-28"-1500)	
8	153-267	1	HOSE (100FX90S-28"-1500)	
9	154-701	1	HOSE (040FX-14"-3000)	
10	159-077	2	SPLIT FLANGE (16SFL)	
11	154-300	2	CONNECTOR (100-12S90)	
12	153-050	1	FILTER HEAD (12 SF)	
13	149-939	1	FILTER ELEMENT	

NOT SHOWN:

FOOTNOTES:

- 1. 500-764 MULTIFUNCTION VALVE (#1)
- 500-1420 SHAFT SEAL
- 500-1419 O-RING
- 149-544 EDC CONTROLLER F/100CC
- 190-981 EDC KIT 75/100/130CC

INCLUDES 190-981

NOTE:

ROTATION MOTOR HYDRAULICS

ENDS WITH S/N: CMWJ30M1A70000011

ENDS WITH S/N: CMWJ30ATK70000011

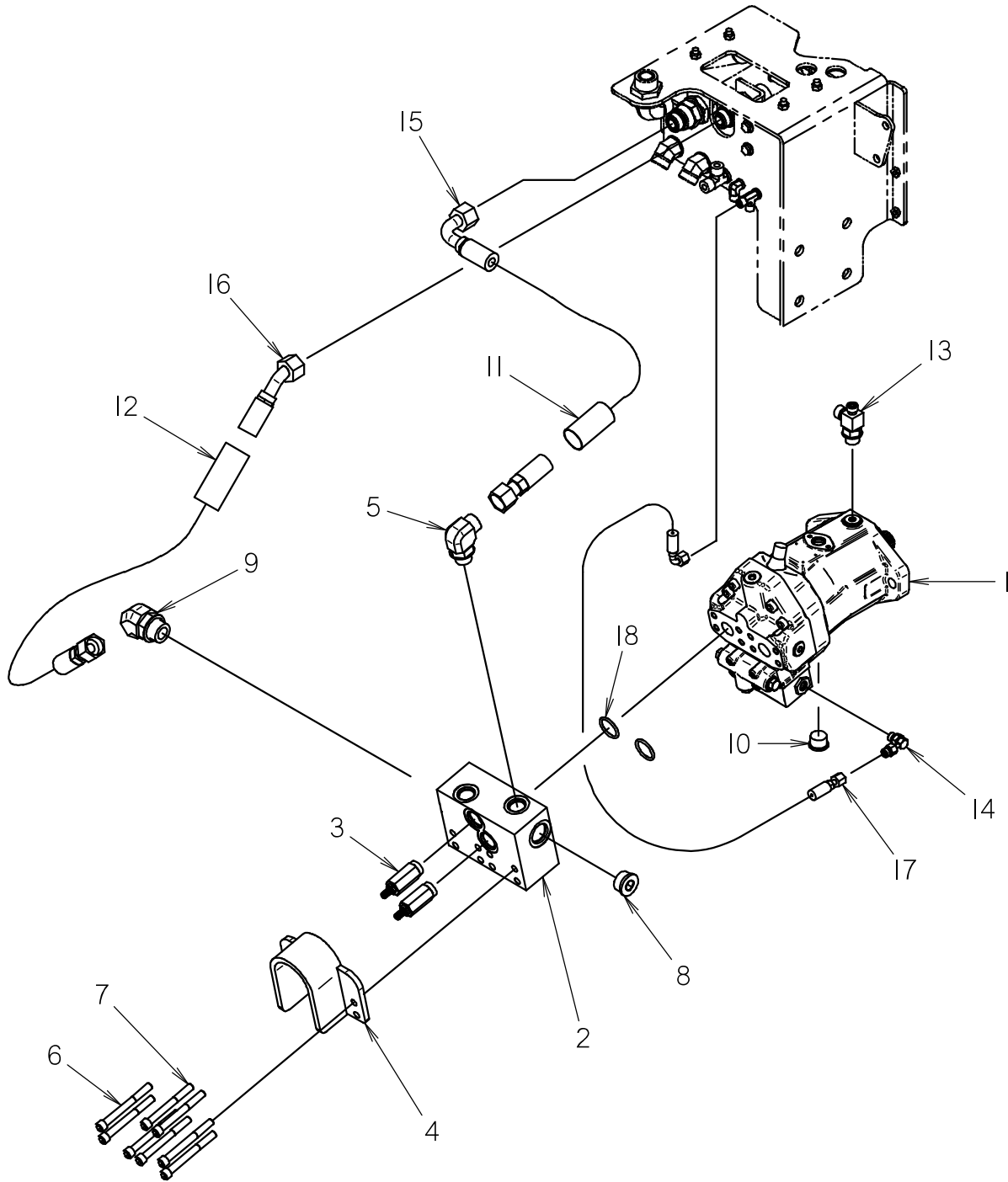

ROTATION MOTOR HYDRAULICS

ENDS WITH S/N: CMWJ30M1A70000011

ENDS WITH S/N: CMWJ30ATK70000011

REF NO.	PART NUMBER	QTY	DESCRIPTION	REMARKS
1	150-1437	1	HYDRAULIC MOTOR	SEE FOOTNOTE 1 FOR SERVICE PARTS
2	150-1443	1	CROSS PORT RELIEF MANIFOLD	
3	150-1657	2	RELIEF CARTRIDGE	SEAL KIT 500-1431
4	300-3652	1	GUARD	
5	154-270	1	CONNECTOR (12S-12090)	
6	107-709	6	SCREW (7/16-NC X 4.25, SOC, GD8)	
7	108-191	2	BOLT (7/16-NC X 4" SOC GR8)	
8	155-184	1	PLUG (16S)	
9	154-358	1	CONNECTOR (120-16S45)	
10	159-392	1	PLUG (12S, SOC)	
11	115-713	1	ABRASION SLEEVE (1.59" X 24")	USE FOR "JT"; FOR "AT" USE 115-754
12	117-224	1	ABRASION SLEEVE (1.59" X 26")	USE FOR "JT" FOR "AT" USE 115-754
13	159-801	1	RUN TEE (10S-060-080)	
14	105-1121	1	CONNECTOR (06S-04090,SPECIAL)	
15	150-1648	1	HOSE (120FX90M-25"-6000)	USE FOR "JT" FOR "AT" USE 150-1667
16	150-1649	1	HOSE (120FX45-27"-6000)	USE FOR "JT"; FOR "AT" USE 150-1668
17	154-802	1	HOSE (040FX90-26"-3000)	USE FOR "JT" AND "AT"
18	157-029	2	O-RING (219 D90)	

NOT SHOWN:

154-326 1 CAP (060F)

INSTALL ON ITEM #13 FOR "JT" ONLY

FOOTNOTES:

- 1. 500-1468 ANTI-CAV RELIEF 3000PSI
- 502-172 SPEED SENSOR
- 500-1426 SHAFT SEAL RING

NOTE:

ROTATION MOTOR HYDRAULICS

BEGINS WITH S/N: JT - CMWJ30M1L70000012; AT - CMWJ30ATT70000012

ENDS WITH S/N: JT - CMWJ30ATT70000031; AT - CMWJ30ATT70000021

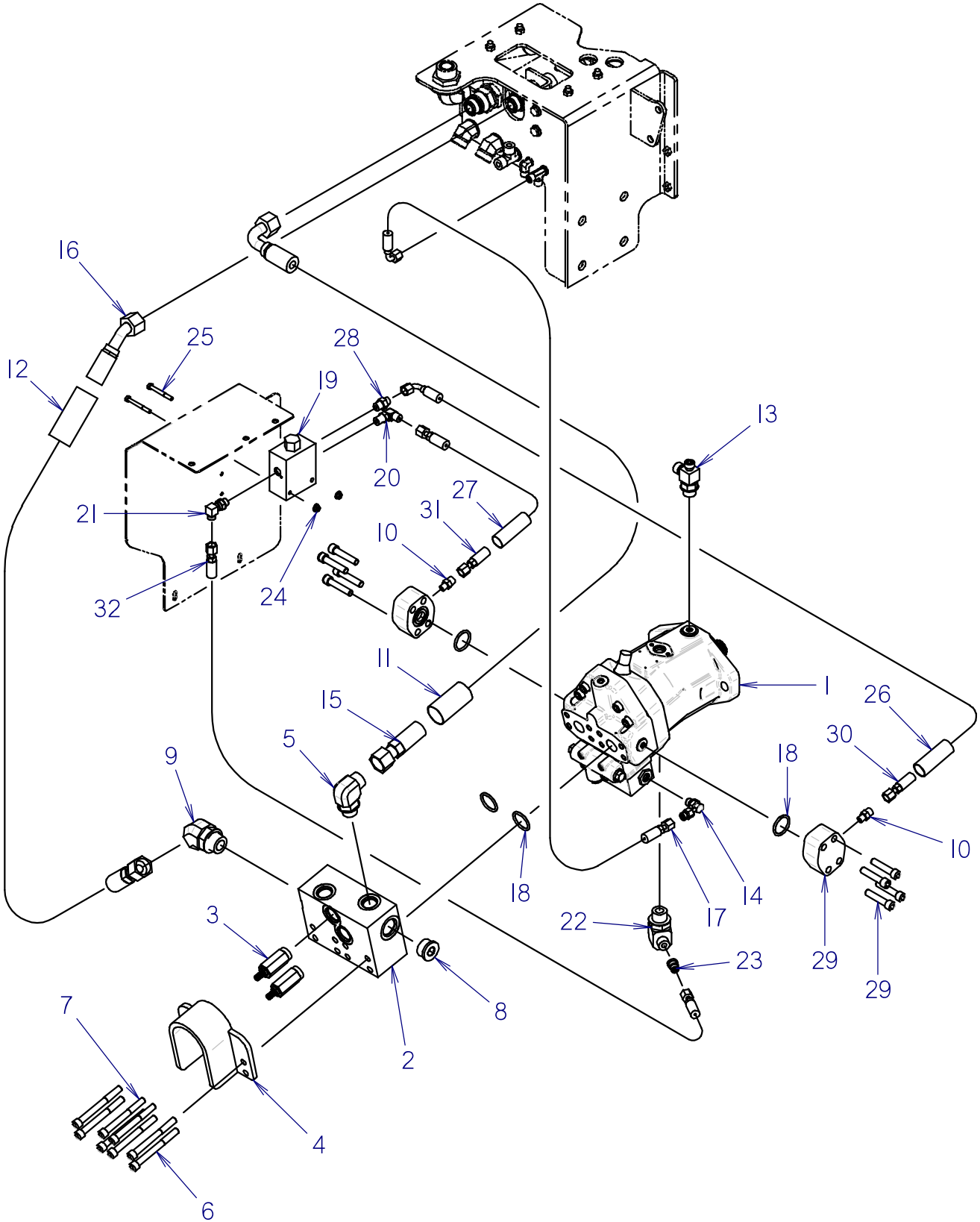

ROTATION MOTOR HYDRAULICS

BEGINS WITH S/N: JT - CMWJ30M1L70000012; AT - CMWJ30ATT70000012

ENDS WITH S/N: JT - CMWJ30ATT70000031; AT - CMWJ30ATT70000021

REF NO.	PART NUMBER	QTY	DESCRIPTION	REMARKS
1	I50-1991	1	HYDRAULIC MOTOR	SEE FOOTNOTE I FOR SERVICE PARTS
2	I50-1443	1	CROSS PORT RELIEF MANIFOLD	
3	I50-1657	2	RELIEF CARTRIDGE	SEAL KIT 500-1431
4	300-3652	1	GUARD	
5	I54-270	1	CONNECTOR (I2S-I2090)	
6	I07-709	6	SCREW (7/16-NC X 4.25, SOC, GD8)	
7	I08-191	2	BOLT (7/16-NC X 4" SOC GR8)	
8	I55-184	1	PLUG (I6S)	
9	I54-358	1	CONNECTOR (I20-I6S45)	
10	I54-278	2	CONNECTOR (04S-040)	
11	I15-713	1	ABRASION SLEEVE (I.59" X 24")	USE FOR "JT"; FOR "AT" USE I15-754
12	I17-224	1	ABRASION SLEEVE (I.59" X 26")	USE FOR "JT"; FOR "AT" USE I15-754
13	I59-801	1	RUN TEE (I0S-060-080)	
14	I05-1121	1	CONNECTOR (06S-04090,SPECIAL)	
15	I50-1648	1	HOSE (I20FX90M-25"-6000)	USE FOR "JT"; FOR "AT" USE I50-1667
16	I50-1649	1	HOSE (I20FX45-27"-6000)	USE FOR "JT"; FOR "AT" USE I50-1668
17	I54-802	1	HOSE (040FX90-26"-3000)	USE FOR "JT" AND "AT"
18	I57-029	2	O-RING (219 D90)	
19	I50-1158	1	HYDRAULIC VALVE	
20	I54-226	1	CONNECTOR (040-06S90)	
21	I50-2002	1	CONNECTOR (040-06S90, ORF)	
22	I54-236	1	CONNECTOR (080-I2S90)	
23	I54-248	1	REDUCER STEM (040)	
24	I06-385	2	FLG LOCKNUT (M6-I.00)	
25	I06-893	2	SCREW (M6-I.00 X 55MM)	
26	I17-409	1	ABRASION SLEEVE (I.00" X 28")	
27	I17-328	1	ABRASION SLEEVE (I.00" X 18")	
28	I54-385	1	CONNECTOR (040-06S, ORF)	
29	300-5278	2	-I6 SAE CODE 62 GAUGE FLANGE	
30	I50-2001	1	HOSE (040FX90S-30" - 6000)	
31	I50-2000	1	HOSE (040FX-I9" - 6000)	USE FOR "JT"; FOR "AT" USE I50-2066
32	515-735	1	HOSE (040FX-22"-3000)	

NOT SHOWN:

I54-326 1 CAP (060F)

INSTALL ON ITEM #13 FOR "JT" ONLY

FOOTNOTES:

- I. 500-1468 SHAFT SEAL
- 502-172 SPEED SENSOR

NOTE:

THRUST PUMP HYDRAULICS

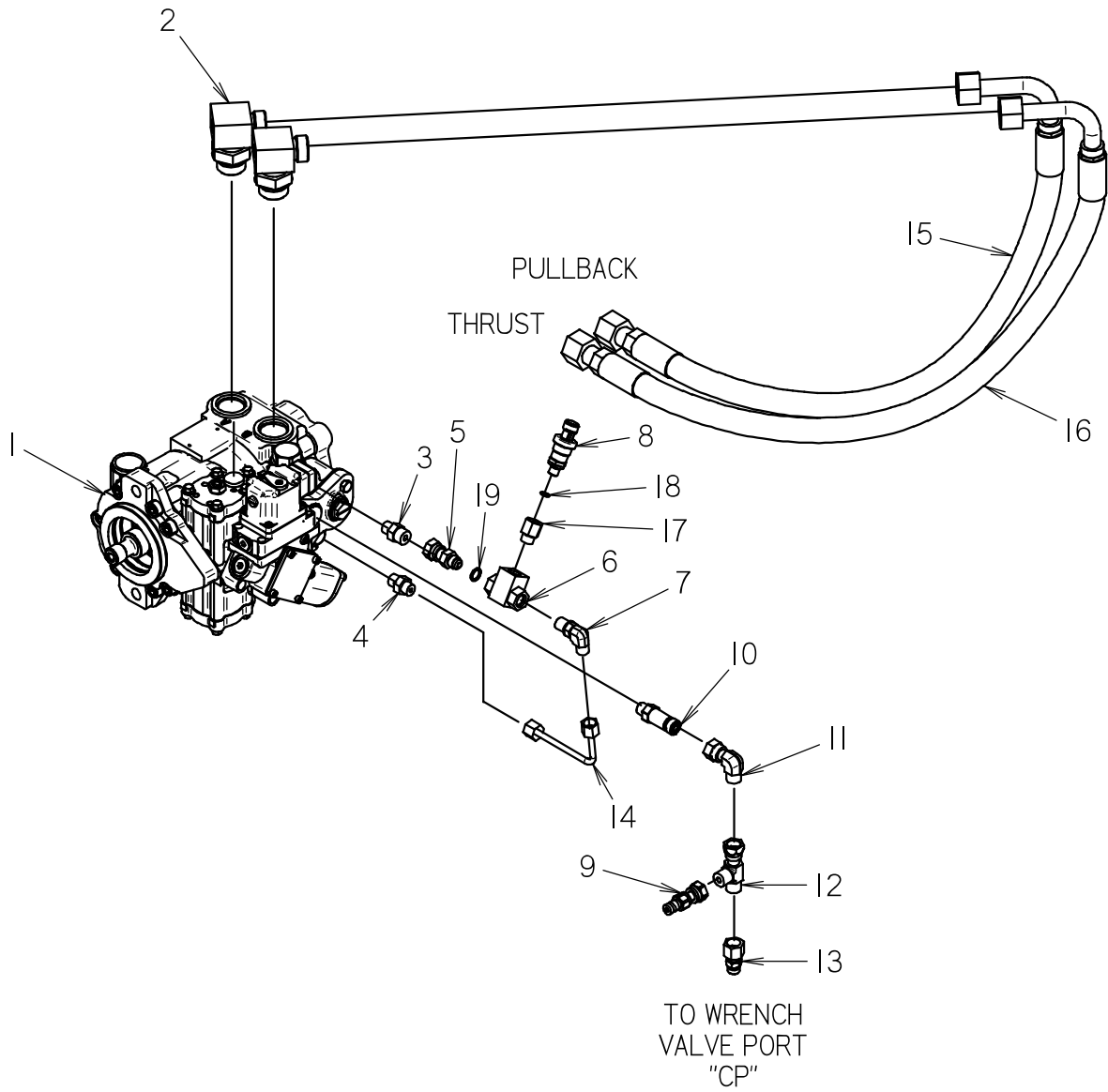

THRUST PUMP HYDRAULICS

REF NO.	PART NUMBER	QTY	DESCRIPTION	REMARKS
1	158-224	1	HYDRAULIC PUMP	SEE FOOTNOTE 1
2	150-1223	2	CONNECTOR (-16S-120-06SF 90)	
3	154-221	1	CONNECTOR (06S-060)	
4	154-220	1	CONNECTOR (040-06S)	
5	514-409	1	UNION (06J-060FX)	
6	159-475	1	SHUTTLE VALVE	
7	154-226	1	CONNECTOR (040-06S90)	
8	214-569	1	PRESSURE TRANSDUCER (6000 PSI)	
9	159-157	1	QDC ADAPTER (02-060F)	
10	156-174	1	CONNECTOR (06S-060 LG)	
11	154-228	1	UNION (060-060FX90)	
12	154-344	1	UN RUN TEE (060FX-060-060)	
13	150-1724	1	CONNECTOR (040-06F0, ORF)	
14	150-1144	1	HYDRAULIC LINE	
15	150-1113	1	HOSE (120FX90L-33"-5000)	
16	150-1114	1	HOSE (120FX90L-35"-5000)	
17	155-254	1	REDUCER (06S-04SF)	
18	155-760	1	O-RING (904 D90)	
19	155-705	1	O-RING (906 D90)	

NOT SHOWN:

FOOTNOTES:

- 1. 217-258 ELECTRIC DISPLACEMENT CONTROL
- 157-568 INTERNAL SEAL
- 152-173 HYD RELIEF VALVE
- 150-1020 SPRING, RELIEF
- 190-1015 SHIM KIT

SHAFT SEAL
5000 PSI
CHARGE RELIEF
CHARGE RELIEF

NOTE:

THRUST MOTOR HYDRAULICS

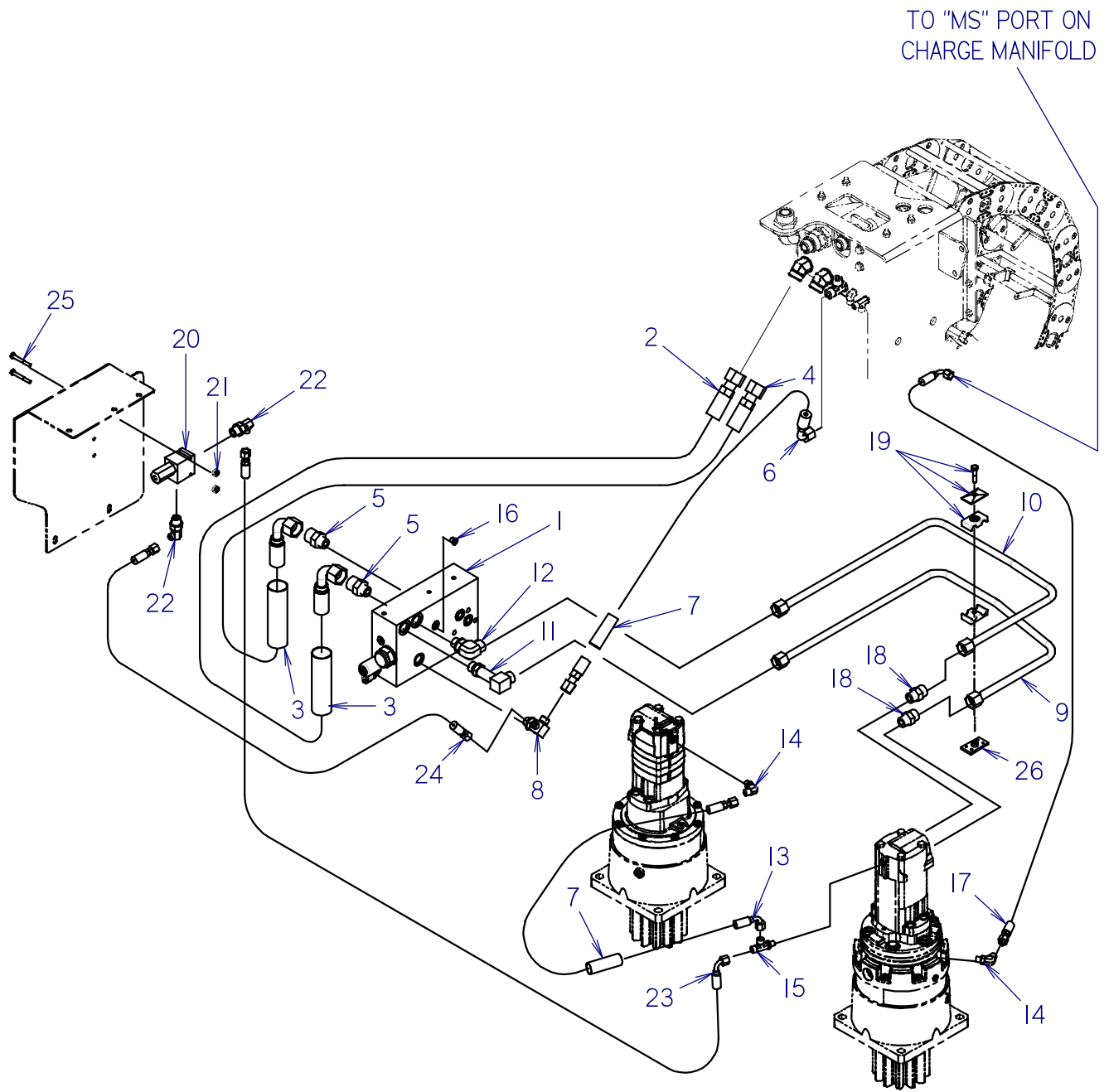

THRUST MOTOR HYDRAULICS

REF NO.	PART NUMBER	QTY	DESCRIPTION	REMARKS
1	152-178	1	MANIFOLD, 2 SPEED THRUST	SEE FOOTNOTE 1 FOR SERVICE PARTS
2	150-1567	1	HOSE (120FX90S-31"-5000)	
3	115-754	2	ABRASION SLEEVE (1.59" X 30")	
4	150-1567	1	HOSE (120FX90S-31"-5000)	
5	154-247	2	CONNECTOR (10S-120)	
6	515-497	1	HOSE (080FX90S-20"-3000)	
7	117-328	2	ABRASION SLEEVE (1.00" X 18")	
8	514-160	1	BRANCH TEE (08S-080-040)	
9	150-1543	1	HYDRAULIC LINE (-10)	
10	150-1544	1	HYDRAULIC LINE (-10)	
11	154-288	1	CONNECTOR (10S-10090, XL)	
12	154-298	1	CONNECTOR (10S-10090)	
13	515-041	1	HOSE (040FX90S-20"-3000)	
14	154-252	2	CONNECTOR (04S-04090)	
15	154-316	1	RUN TEE (04S-040-040)	
16	154-383	1	PLUG (04S)	
17	154-728	1	HOSE (040FX90S-36"-3000)	
18	154-301	2	CONNECTOR (10S-100)	
19	111-146	1	BOLT ON CLAMP (5/8" X 5/8" SET)	
20	150-2026	1	RELIEF VALVE	
21	105-832	2	FLG LOCKNUT (1/4-NC)	
22	154-276	2	CONNECTOR (040-08S90)	
23	149-362	1	HOSE (040FX90S-46"-3000)	
24	154-701	1	HOSE (040FX-14"-3000)	
25	105-106	2	BOLT (1/4-NC X 2")	
26	323-551	1	WELD PLATE (SP2D)	

NOT SHOWN:

FOOTNOTES:

- 1. 150-1328 CARTRIDGE VALVE
- 500-1432 SOLENOID (USE WITH 150-1328)
- 150-1329 PILOT VALVE
- 150-1909 SHUTTLE VALVE CARTRIDGE

NOTE:

PISTON PUMP HYDS - DRILLING FLUID, WRENCHES & ANCHOR

ENDS WITH S/N: JT-CMW30M1C80000131, AT-CMWJ30ATC80000062

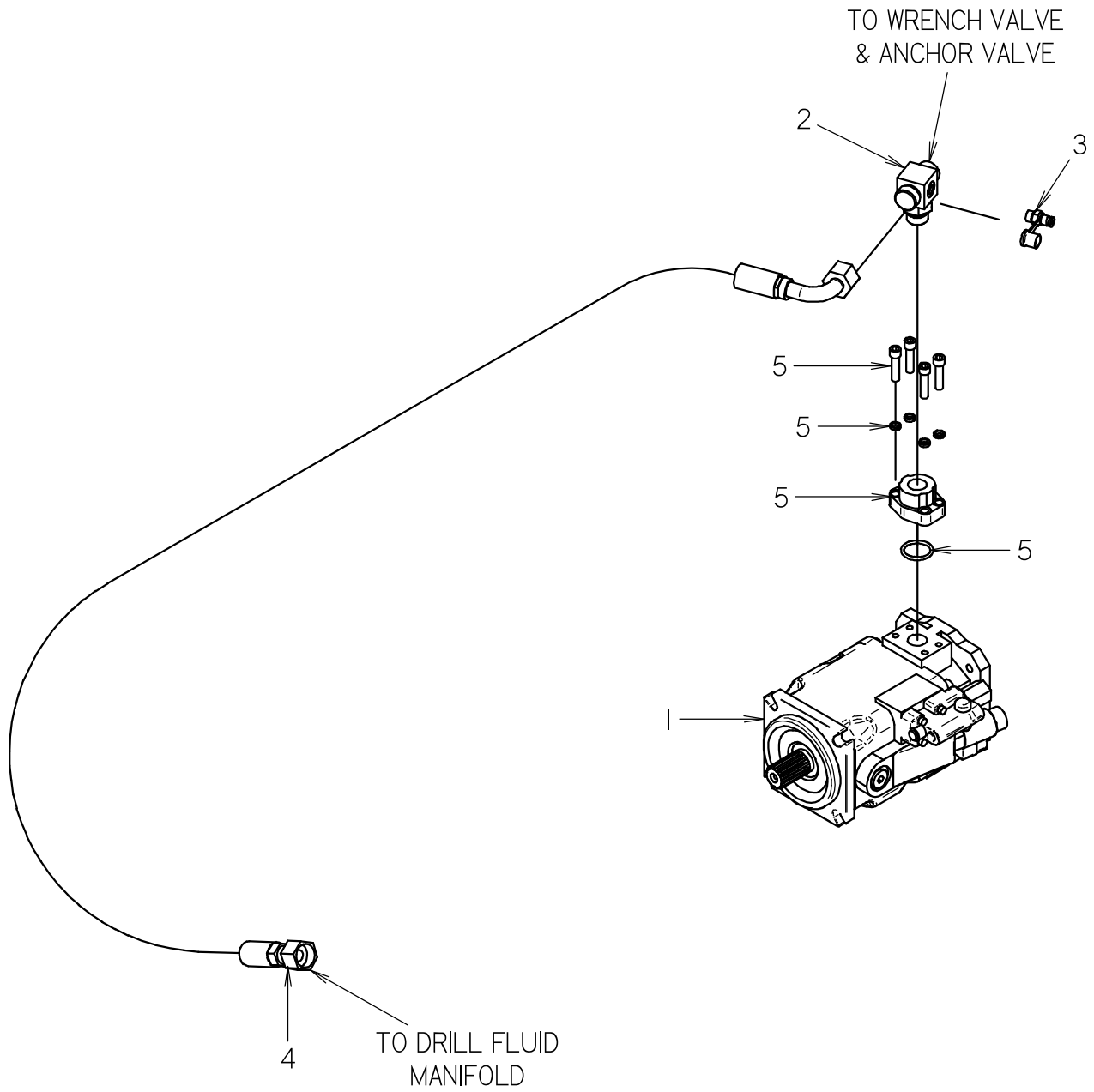

PISTON PUMP HYDS - DRILLING FLUID, WRENCHES & ANCHOR ENDS WITH S/N: JT-CMW30M1C80000131, AT-CMWJ30ATC80000062

REF NO.	PART NUMBER	QTY	DESCRIPTION	REMARKS
1	I50-I489	1	PUMP, ELECTRIC CONTROL (63CC)	SEE FOOTNOTE 1 FOR SERVICE PARTS
2	I50-I207	1	BRANCH TEE (I2S-I20-I20-04SF)	
3	I59-I54	1	QDC ADAPTER (02-04S)	
4	I50-I553	1	HOSE (I20FX90-I30"-4000)	
5	I05-I033	1	FITTING, 1" CD 6I X -I2 SAE FEMALE	

NOT SHOWN:

FOOTNOTES:

- I. 500-I423 CONTROL VALVE
- 500-I424 SHAFT SEAL
- 500-I425 RETAINING RING

NOTE:

PISTON PUMP HYDS - DRILLING FLUID, WRENCHES & ANCHOR BEGINS WITH S/N: JT-CMWJ30M1T80000132, AT-CMWJ30ATV80000063

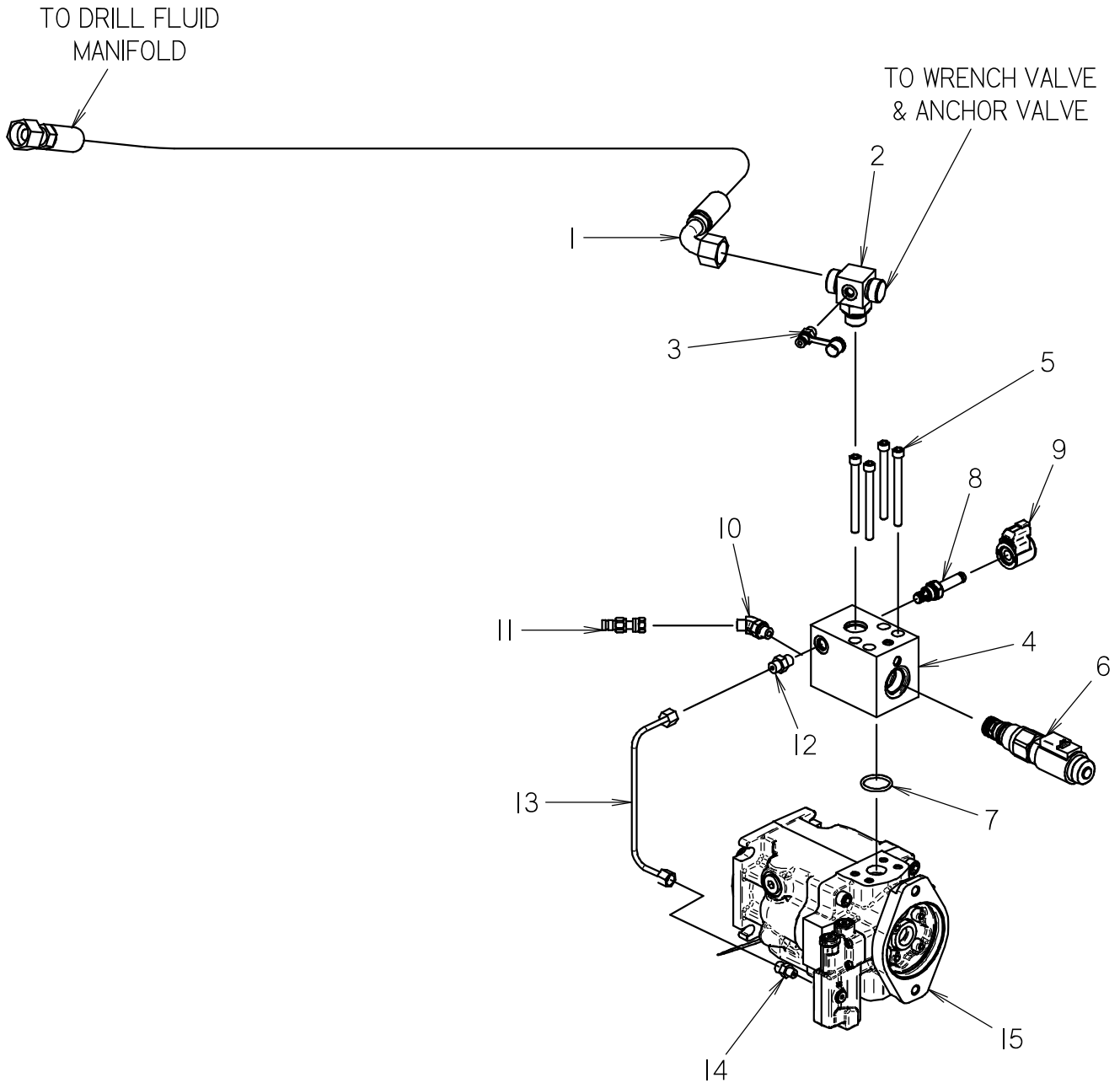

PISTON PUMP HYDS - DRILLING FLUID, WRENCHES & ANCHOR BEGINS WITH S/N: JT-CMWJ30M1T80000132, AT-CMWJ30ATV80000063

REF NO.	PART NUMBER	QTY	DESCRIPTION	REMARKS
1	150-1553	1	HOSE (120FX90-130"-4000)	
2	150-1207	1	BRANCH TEE (12S-120-120-04SF)	
3	159-154	1	QDC ADAPTER (02-04S)	
4	150-2137	1	PROPORTIONAL CARTRIDGE MANIFOLD	
5	105-1296	4	BOLT (3/8-NC X 4", SOC, GD8)	
6	500-1567	1	PORT VALVE	TORQUE TO 100 FT. LBS.
7	157-029	1	O-RING (219 D90)	
8	500-1575	1	2-POS, 2-WAY BLOCKING VALVE	TORQUE TO 20 FT. LBS.
9	500-1311	1	SOLENOID COIL, 12VDC w/ ZENER DIODE	SEE FOOTNOTE 1 FOR SERVICE PARTS
10	154-250	1	CONNECTOR (040-06S45)	
11	159-156	1	QDC ADAPTER (02-040F)	
12	154-220	1	CONNECTOR (040-06S)	
13	150-2130	1	HYDRAULIC LINE (-04)	
14	154-278	1	CONNECTOR (04S-040)	
15	150-2113	1	LOAD SENSE PISTON PUMP, 60CC	

NOT SHOWN:

FOOTNOTES:

1. 217-864 SOLENOID COIL W/CONNECTOR

NOTE:

AUXILIARY PUMP HYDRAULICS

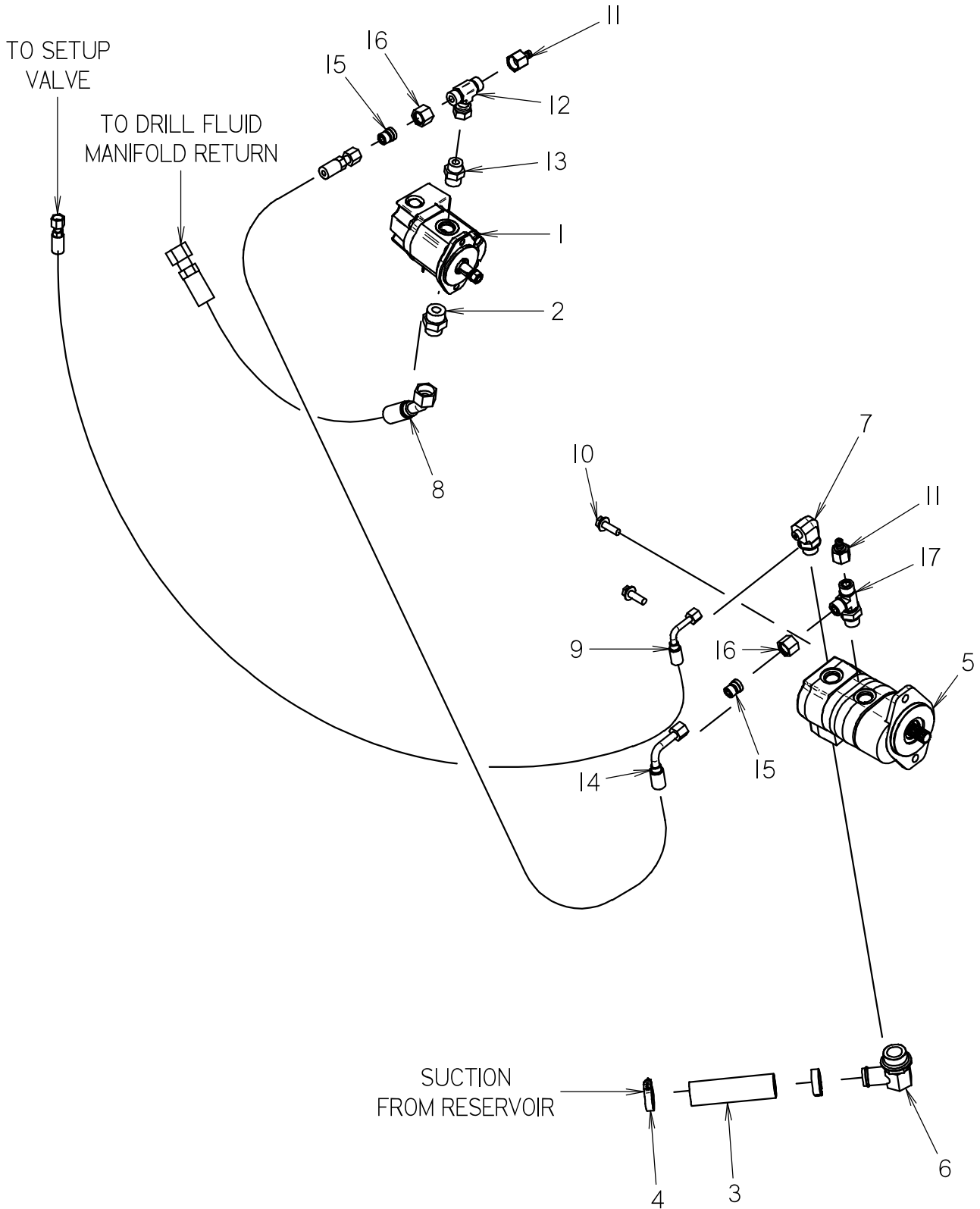

AUXILIARY PUMP HYDRAULICS

REF NO.	PART NUMBER	QTY	DESCRIPTION	REMARKS
1	150-1051	1	HYDRAULIC MOTOR	FAN DRIVE, SEE FOOTNOTE 1
2	154-367	1	CONNECTOR (120-16S)	
3	116-587	42	BULK HOSE (1-1/4",SOLD PER FT)	1 @ 42"
4	149-342	2	T-BOLT CLAMP (1.687")	
5	152-163	1	TANDEM PUMP	SEE FOOTNOTE 2
6	155-168	1	S/O COUPLER (20S-20H90)	
7	514-197	1	CONNECTOR (060-12S90)	
8	150-1556	1	HOSE (120FX45-45"-3000)	
9	150-1562	1	HOSE (060FX90L-106"-4000)	
10	106-632	2	FLG LK SCR (M12-1.75X35MM,SER)	
11	159-159	2	QDC ADAPTER (02-100FX)	
12	154-325	1	UN BR TEE (100FX-100-100)	
13	154-308	1	CONNECTOR (100-12S)	
14	150-1555	1	HOSE (080FX90L-100"-3000)	WITHOUT AC ONLY
15	154-312	2	REDUCER STEM (080)	
16	154-310	2	REDUCER NUT (100F)	
17	154-370	1	RUN TEE (12S-100-100)	

NOT SHOWN:

FOOTNOTES:

1. 500-1316 SEAL SERVICE KIT
500-1317 SOLENOID
500-1318 PROP, RELIEF VALVE
500-1319 SPEED SENSOR ASSEMBLY
2. 195-1205 GASKET
500-1410 SEAL REPAIR KIT

NOTE:

SELECTOR VALVE HYDRAULICS

- A TO LEFT TRACK MOTOR, FOWARD
- B TO LEFT TRACK MOTOR, REVERSE
- C FROM OUTER ROTATION PUMP PORT B, REV/BREAKOUT
- D FROM OUTER ROTATION PUMP PORT A, FWD/MAKE UP
- E BREAK OUT
- F MAKE UP
- G TO RIGHT TRACK MOTOR, REVERSE
- H TO RIGHT TRACK MOTOR, FORWARD
- J FROM THRUST PUMP PORT A, REV/PULL BACK
- K FROM THRUST PUMP PORT B, FWD/THRUST
- L PULL BACK
- M THRUST
- N RETURN FROM DWA PUMP
- P FROM CHARGE PRESSURE VALVE

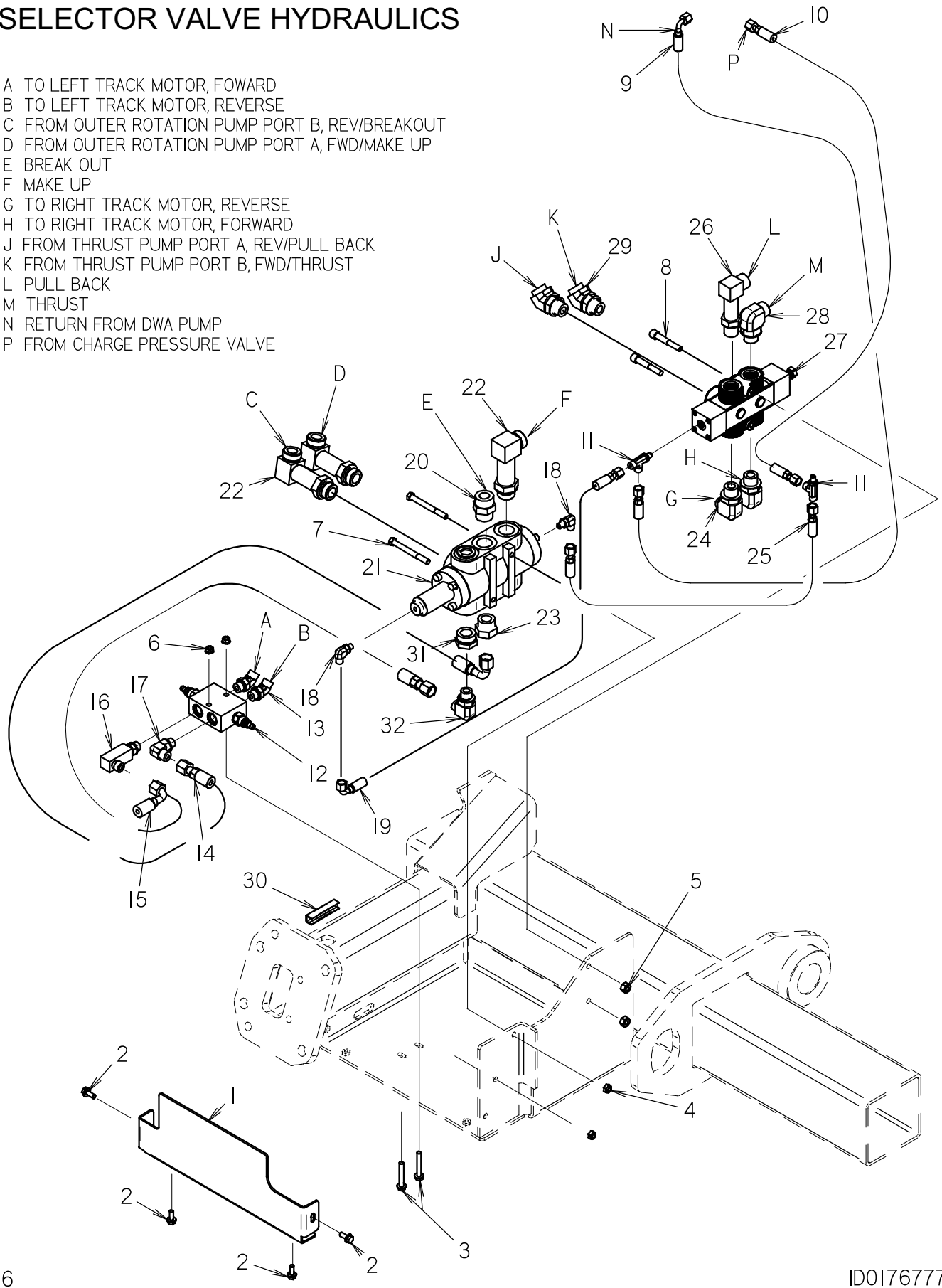

SELECTOR VALVE HYDRAULICS

REF NO.	PART NUMBER	QTY	DESCRIPTION	REMARKS
1	300-3341	1	COVER	
2	106-162	4	FLG SCREW (M8-1.25 X 20MM, GD8)	
3	105-665	2	FLG SCREW (M8-1.25 X 55MM)	
4	105-047	2	LOCKNUT (3/8-NC)	
5	105-894	2	LOCKNUT (M10-1.50, PRV TRQ, 10.9)	
6	106-386	2	FLG LOCKNUT (M8-1.25)	
7	105-258	2	BOLT (3/8-NC X 3-3/4")	
8	106-725	2	SCREW (M10-1.50 X 65MM, SOC)	
9	515-447	1	HOSE (040FX90S-48"-3000)	
10	515-013	1	HOSE (040FX-41"-3000)	
11	154-316	2	RUN TEE (04S-040-040)	
12	150-1453	1	RELIEF ASSEMBLY	SEE FOOTNOTE 1 FOR SERVICE PARTS
13	154-284	2	CONNECTOR (08S-08045)	
14	150-1575	1	HOSE (080FX90M-8.25"-5000)	
15	150-2235	1	HOSE (080FX90-32"-5000)	REPLACES 150-1576; SEE FOOTNOTE 3
16	154-254	1	CONNECTOR (08S-08090, XL)	
17	154-235	1	CONNECTOR (08S-08090)	
18	154-252	2	CONNECTOR (04S-04090)	
19	153-364	1	HOSE (040FX90S-13"-3000)	
20	154-281	1	CONNECTOR (16S-160)	
21	150-1408	1	6-WAY SELECTOR	SEE FOOTNOTE 2 FOR SERVICE PARTS
22	154-289	3	CONNECTOR (16S-16090, XL)	
23	154-307	1	CONNECTOR (16S-080)	
24	154-236	2	CONNECTOR (080-12S90)	
25	154-701	1	HOSE (040FX-14"-3000)	
26	154-338	1	CONNECTOR (12S-12090, XL)	
27	159-912	1	HYD CONTROL VALVE	500-1942 SEAL WASHER
28	154-270	1	CONNECTOR (12S-12090)	
29	154-251	2	CONNECTOR (12S-12045)	
30	116-259	8	BULK EDGE (1/2", SOLD PER FT)	1 @ 8"
31	155-199	1	REDUCER (16S-10SF)	
32	154-322	1	CONNECTOR (080-10S90)	

NOT SHOWN:

FOOTNOTES:

1. 150-1452 RELIEF CARTRIDGE
2. 500-1412 SEAL KIT
500-1413 SPRING
3. USE ITEMS #31 155-199 & #32 154-322 WHEN REPLACING 150-1576

NOTE:

CHARGE PRESSURE VALVE

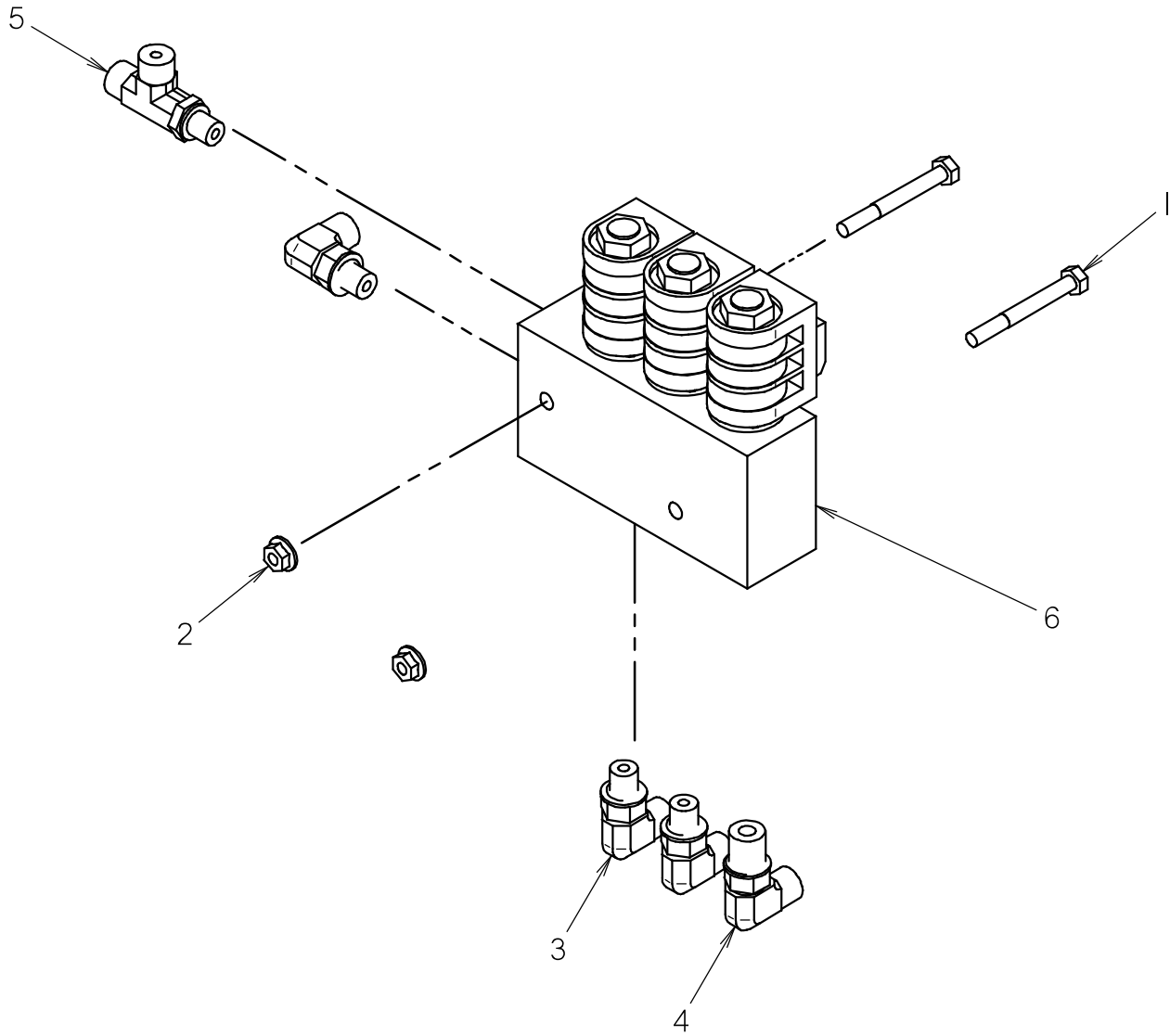

CHARGE PRESSURE VALVE

REF NO.	PART NUMBER	QTY	DESCRIPTION	REMARKS
1	106-893	2	SCREW (M6-1.00 X 55MM)	
2	106-385	2	FLG LOCKNUT (M6-1.00)	
3	154-252	3	CONNECTOR (04S-04090)	
4	154-226	1	CONNECTOR (040-06S90)	
5	154-316	1	RUN TEE (04S-040-040)	
6	159-554	1	MANIFOLD (3-SP)	SEE FOOTNOTE 1

NOT SHOWN:

FOOTNOTES:

1. 499-446 SOLENOID (3 WAY-2 POS VALVE)
214-491 COIL, 12V

NOTE:

CHARGE PRESSURE HYDRAULICS

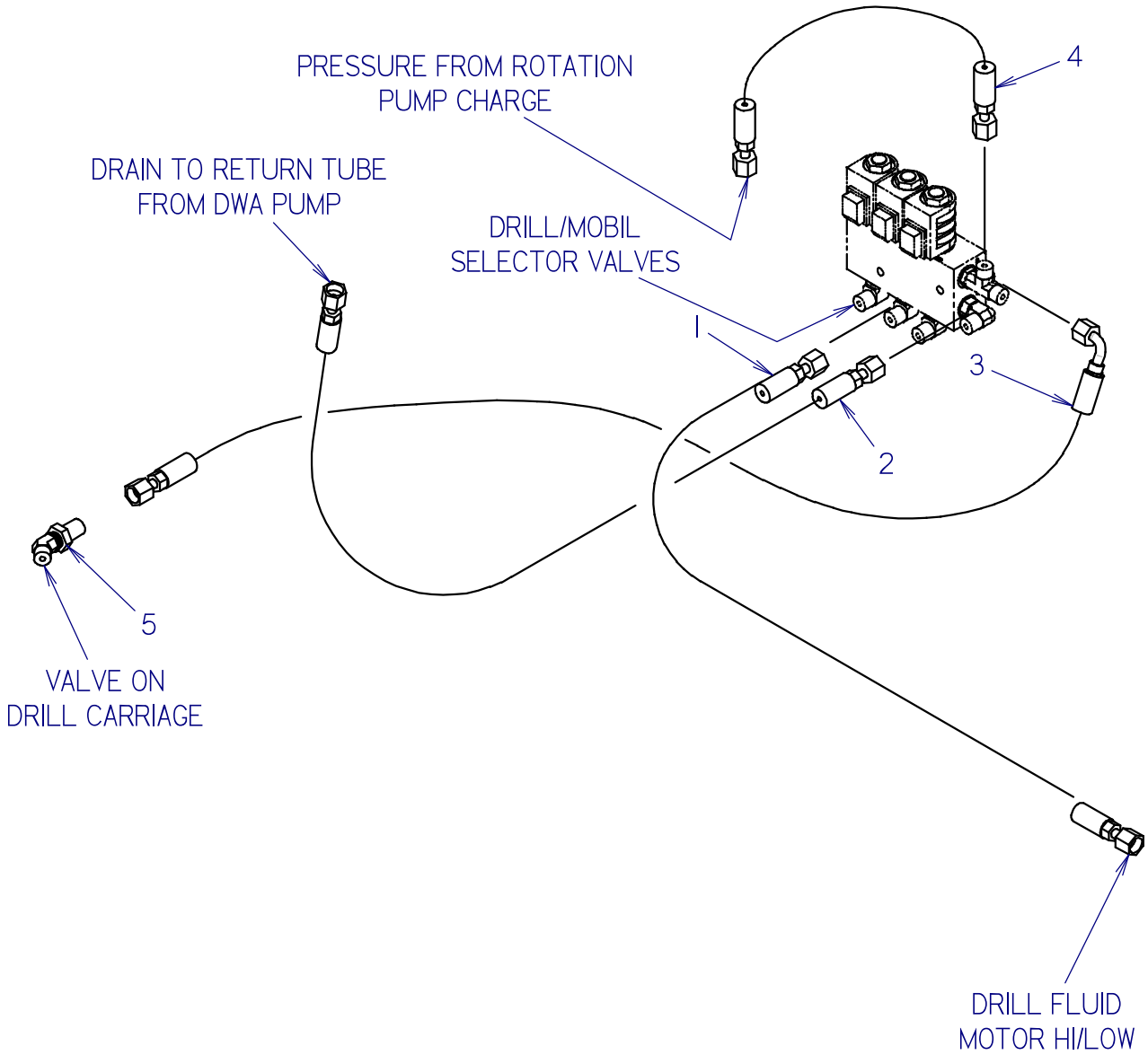

CHARGE PRESSURE HYDRAULICS

REF NO.	PART NUMBER	QTY	DESCRIPTION	REMARKS
1	515-142	1	HOSE (040FX-135"-3000)	
2	154-911	1	HOSE (040FX-36"-3000-AR)	
3	154-728	1	HOSE (040FX90-36"-3000)	
4	154-701	1	HOSE (040FX-14"-3000)	
5	154-285	1	BK CONNECTOR (040-04045BK)	

NOT SHOWN:

FOOTNOTES:

NOTE:

P.O.R. RELIEF HYDRAULICS

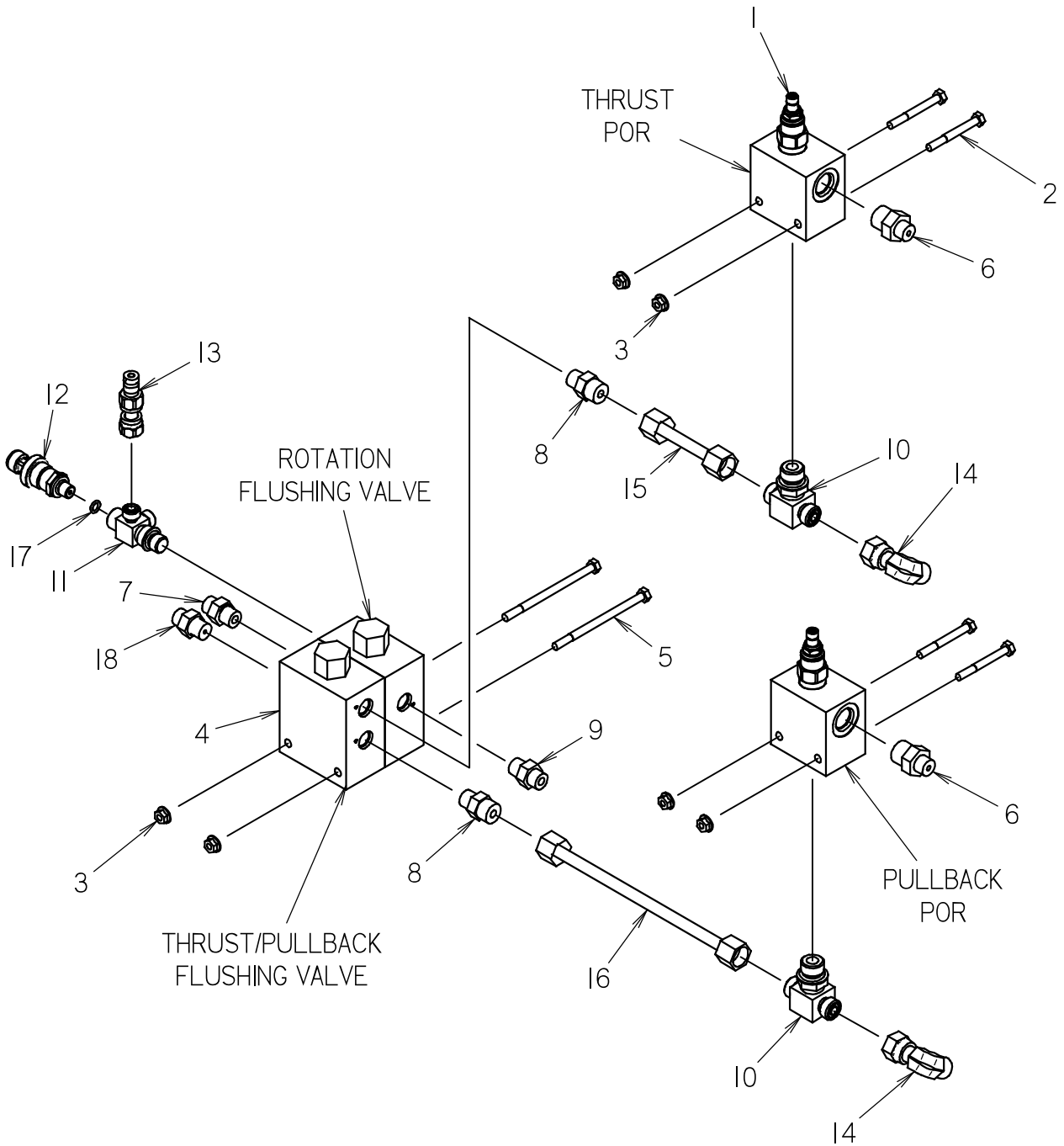

P.O.R. RELIEF HYDRAULICS

REF NO.	PART NUMBER	QTY	DESCRIPTION	REMARKS
1	150-3182	2	HYDRAULIC RELIEF VALVE	
2	106-893	4	SCREW (M6-1.00 X 55MM)	
3	106-385	6	FLG LOCKNUT (M6-1.00)	
4	150-1158	2	HYDRAULIC VALVE	SHUTTLE VALVE CARTRIDGE 150-1898
5	106-945	2	SCREW (M6-1.00 X 100MM)	
6	154-261	2	CONNECTOR (040-08S)	
7	154-220	1	CONNECTOR (040-06S)	
8	154-221	2	CONNECTOR (06S-060)	
9	150-1651	1	CONNECTOR (040-06S. ORF)	
10	159-745	2	TEE (08S-060-060, .60 ORF)	
11	150-1150	1	CONNECTOR (06S-04SF-040-040)	
12	214-569	1	PRESSURE TRANSDUCER (6000 PSI)	
13	159-156	1	QDC ADAPTER (02-040F)	
14	154-228	2	UNION (060-060FX90)	
15	150-1233	1	HARDLINE (-06)	
16	150-1234	1	HARDLINE (-06)	
17	155-760	1	O-RING (904 D90)	
18	514-018	1	CONNECTOR (040-06S. ORF)	

NOT SHOWN:

FOOTNOTES:

NOTE:

GROUND DRIVE HYDRAULICS

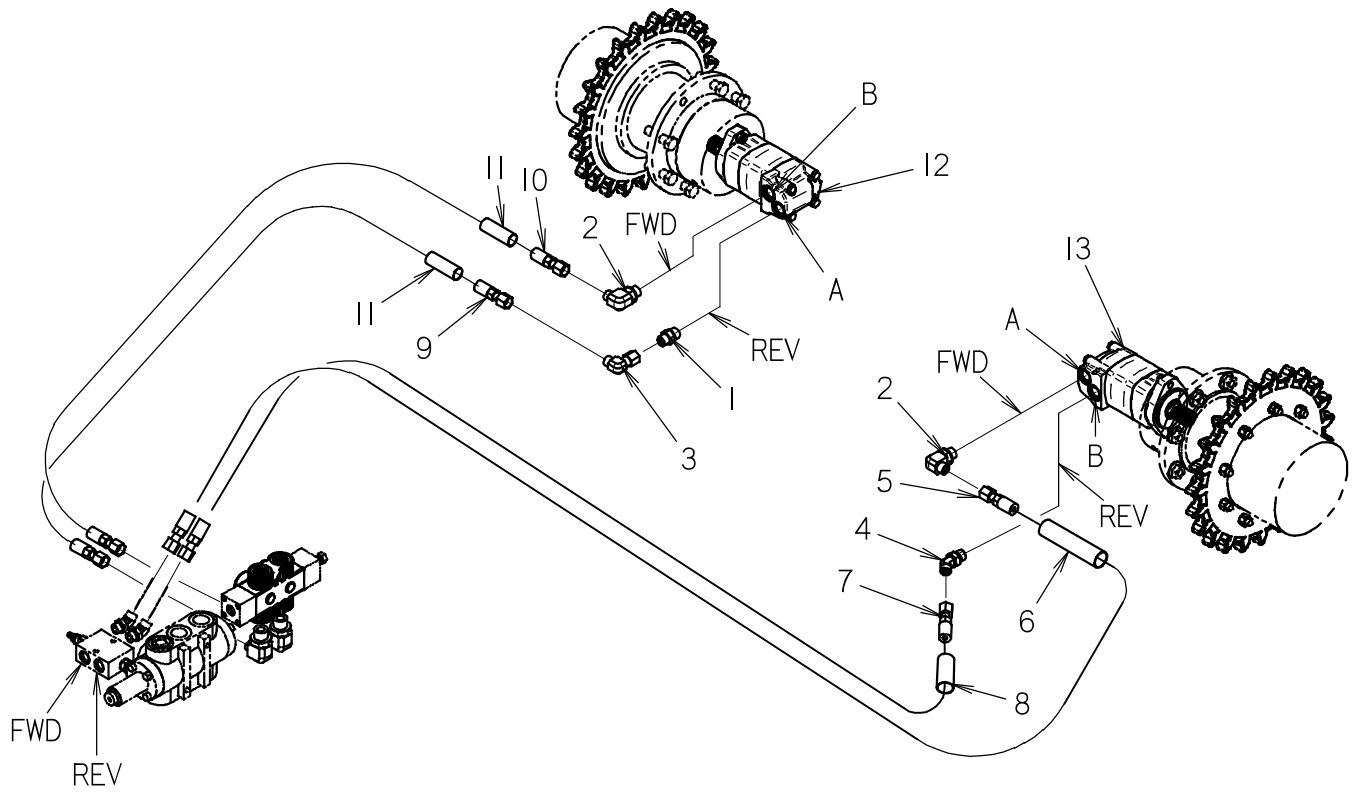

GROUND DRIVE HYDRAULICS

REF NO.	PART NUMBER	QTY	DESCRIPTION	REMARKS
1	154-279	1	CONNECTOR (080-10S)	
2	154-322	2	CONNECTOR (080-10S90)	
3	154-256	1	UNION (080-080FX90)	
4	154-264	1	CONNECTOR (080-10S45)	
5	150-1586	1	HOSE (080FX-114"-5000)	
6	105-1123	1	ABRASION SLEEVE (1.25" X 106")	
7	150-1586	1	HOSE (080FX-114"-5000)	
8	117-389	1	ABRASION SLEEVE (1.25" X 104")	
9	150-1587	1	HOSE (080FX-86"-5000)	
10	150-1588	1	HOSE (080FX-87"-5000)	
11	117-390	2	ABRASION SLEEVE (1.25" X 85")	
12	157-930	1	HYDRAULIC MOTOR	500-658 SEAL REPAIR KIT
13	158-929	1	HYDRAULIC MOTOR	500-658 SEAL REPAIR KIT,500-1653 SHAFT & BEARING KIT

NOT SHOWN:

FOOTNOTES:

NOTE:

GROUND DRIVE BRAKE HYDRAULICS

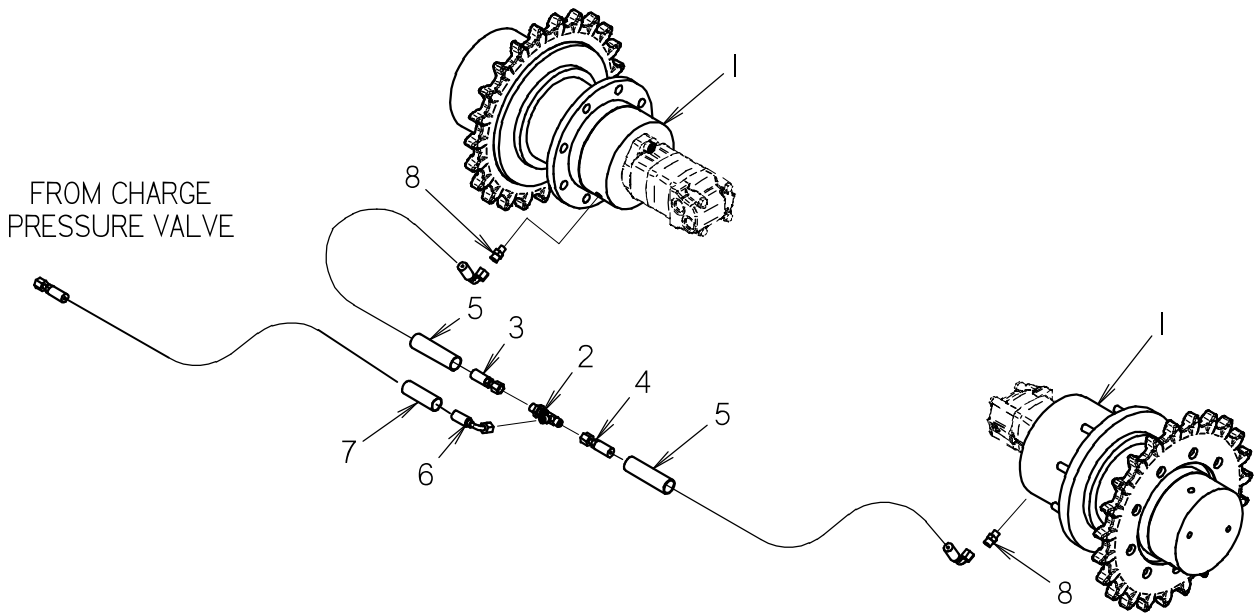

GROUND DRIVE BRAKE HYDRAULICS

REF NO.	PART NUMBER	QTY	DESCRIPTION	REMARKS
1	166-614	2	PLANETARY GEARBOX	SEE NOT SHOWN FOR SERVICE PARTS
2	154-424	1	BK RUN TEE (040-040-040BK)	
3	154-706	1	HOSE (040FX90S-40"-3000)	
4	154-706	1	HOSE (040FX90S-40"-3000)	
5	117-410	2	ABRASION SLEEVE (1.00" X 38")	
6	154-964	1	HOSE (040FX90-70"-3000)	
7	117-702	1	ABRASION SLEEVE (1.00" X 68")	
8	154-278	2	CONNECTOR (04S-040)	

NOT SHOWN:

500-1919 INPUT SHAFT
 500-658 SEAL KIT
 105-1354 BOLT
 500-2009 O-RING/GASKET KIT
 500-2118 DISENGAGE SPRING
 500-2119 DISENGAGE WASHER

FOOTNOTES:

NOTE:

SET-UP VALVE

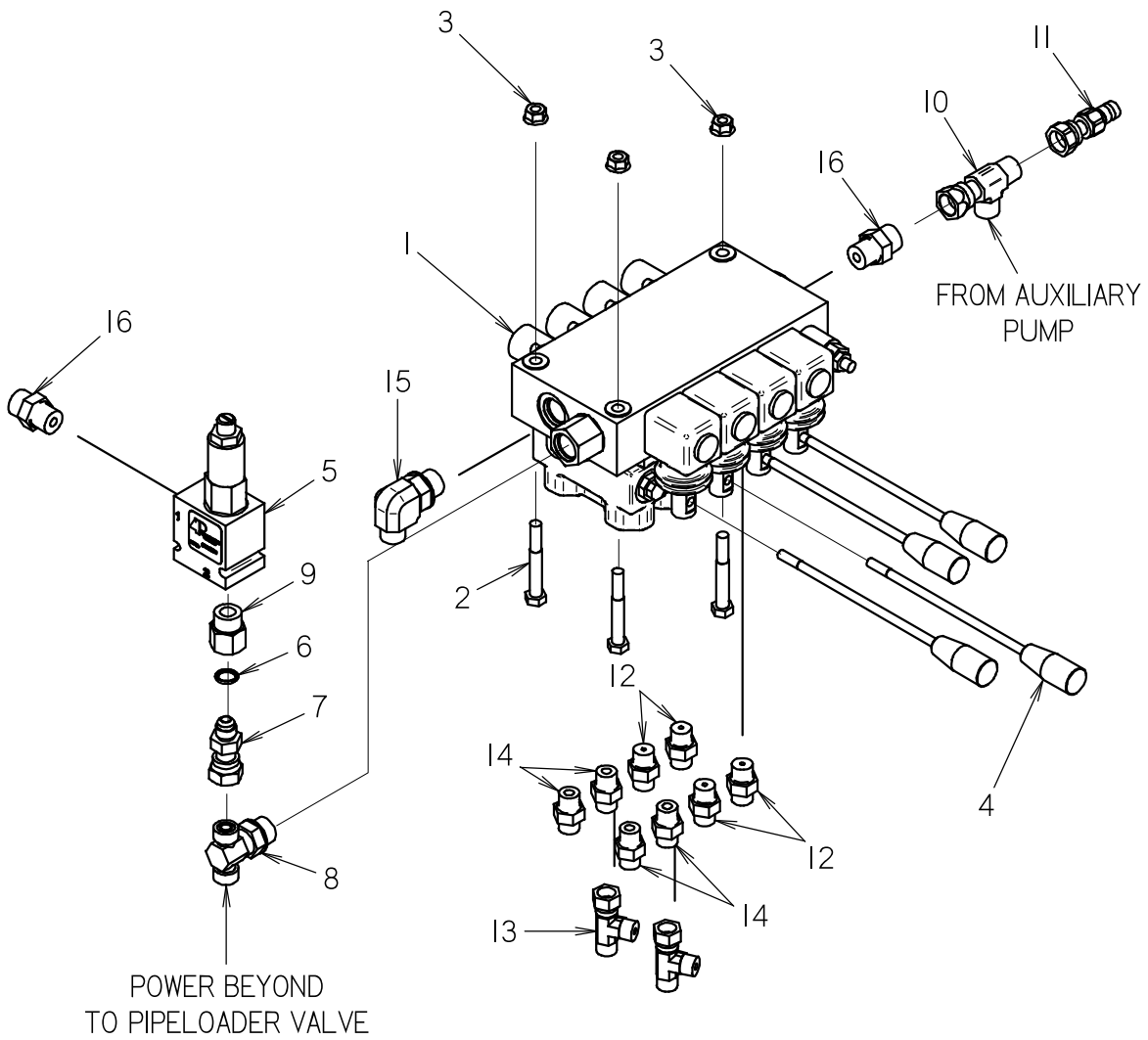

SET-UP VALVE

REF NO.	PART NUMBER	QTY	DESCRIPTION	REMARKS
1	150-1415	1	VALVE	SEE FOOTNOTE 1 FOR SERVICE PARTS
2	106-570	3	SCREW (M8-1.25 X 60MM)	
3	106-386	3	FLG LOCKNUT (M8-1.25)	
4	365-426	4	LEVER (M8-1.25 X 200MM)	
5	158-681	1	RELIEF VALVE (AUXILIARY)	
6	155-705	1	O-RING (906 D90)	
7	514-409	1	UNION (06J-060FX)	
8	154-483	1	BRANCH TEE (08S-060-060)	
9	155-163	1	REDUCER (08S-06SF)	
10	154-344	1	UN RUN TEE (060FX-060-060)	
11	159-157	1	QDC ADAPTER (02-060F)	
12	514-018	4	CONNECTOR (040-06S, ORF)	
13	154-265	2	UNION RUN TEE (040FX-040-040)	
14	154-385	4	CONNECTOR (040-06S, ORF)	
15	154-227	1	CONNECTOR (060-08S90)	
16	154-222	2	CONNECTOR (060-08S)	

NOT SHOWN:

FOOTNOTES:

- I. 153-063 VALVE SPRING KIT
- 499-143 VALVE LEVER
- 500-969 POWER BEYOND SLEEVE
- 500-1046 BP3/SD5 LOCKOUT VALVE
- 150-1799 RELIEF VALVE SD5 DIRECT ACTING
- 500-1611 O-RING (BETWEEN LOCKOUT VALVE AND MAIN BODY)

NOTE:

FRONT TILT RELIEF

BEGINS WITH S/N: JT-CMWJ30M1P70000020; AT-CMWJ30ATE70000021

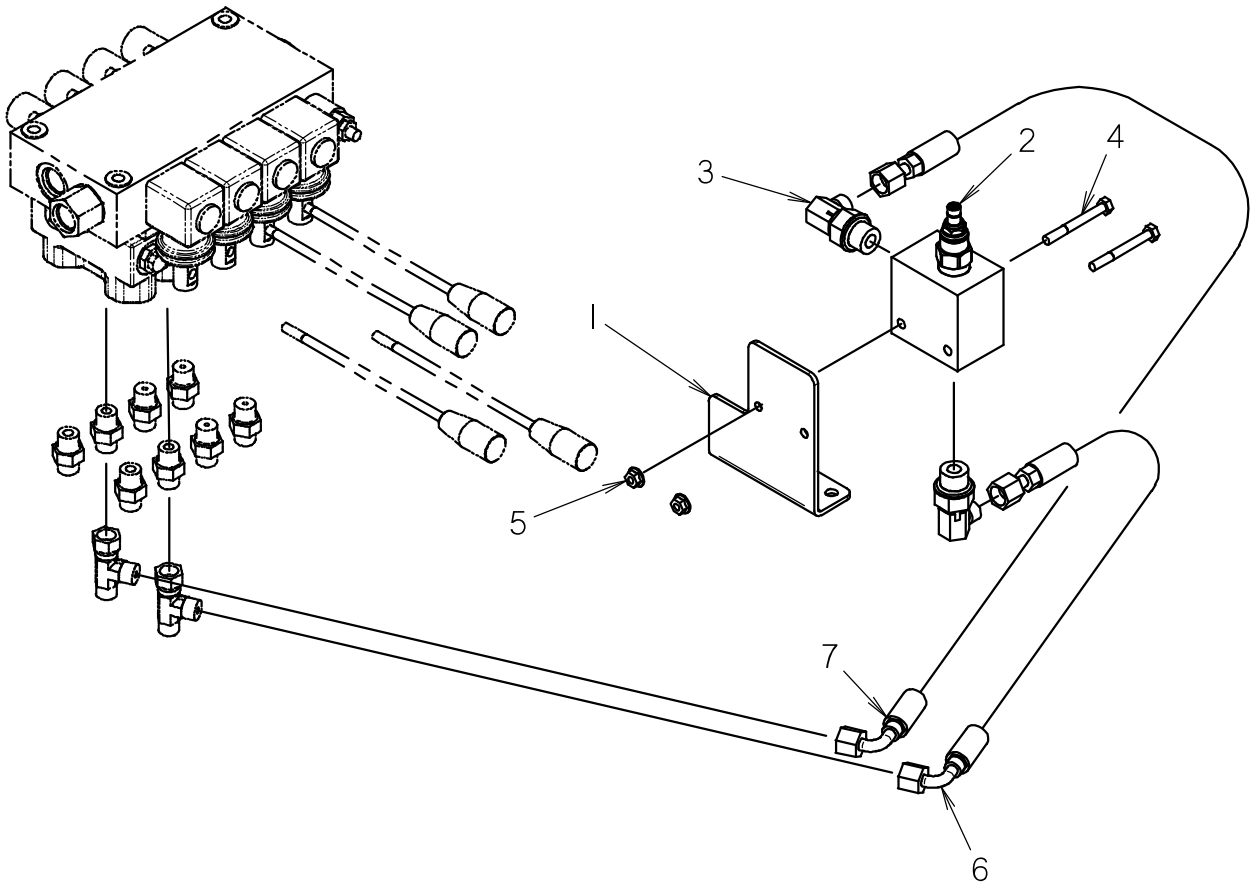

FRONT TILT RELIEF

BEGINS WITH S/N: JT-CMWJ30M1P70000020; AT-CMWJ30ATE70000021

REF NO.	PART NUMBER	QTY	DESCRIPTION	REMARKS
1	300-6746	1	VALVE MOUNT	
2	150-3182	1	HYDRAULIC RELIEF VALVE	
3	154-276	2	CONNECTOR (040-08S90)	
4	106-893	2	SCREW (M6-1.00 X 55MM)	
5	106-385	2	FLG LOCKNUT (M6-1.00)	
6	515-305	1	HOSE (040FX90S-21"-5000)	
7	515-305	1	HOSE (040FX90S-21"-5000)	

NOT SHOWN:

FOOTNOTES:

NOTE:

PIVOT HYDRAULICS

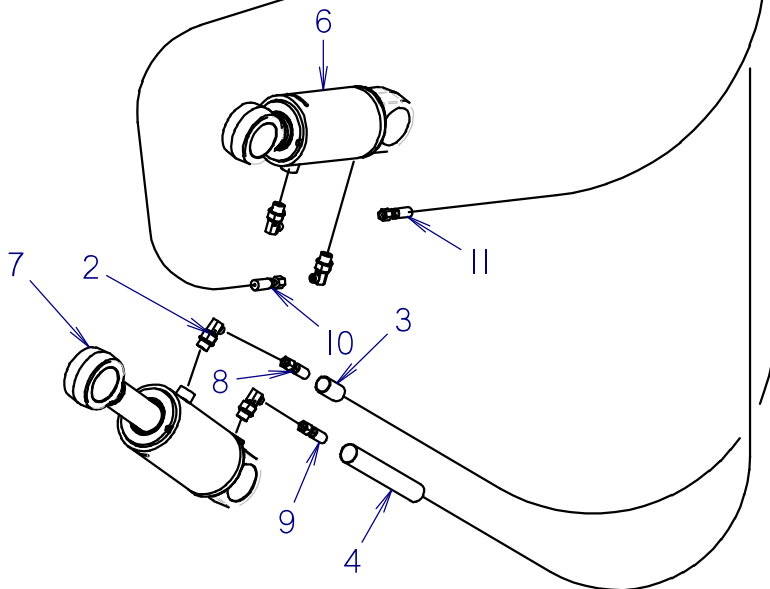
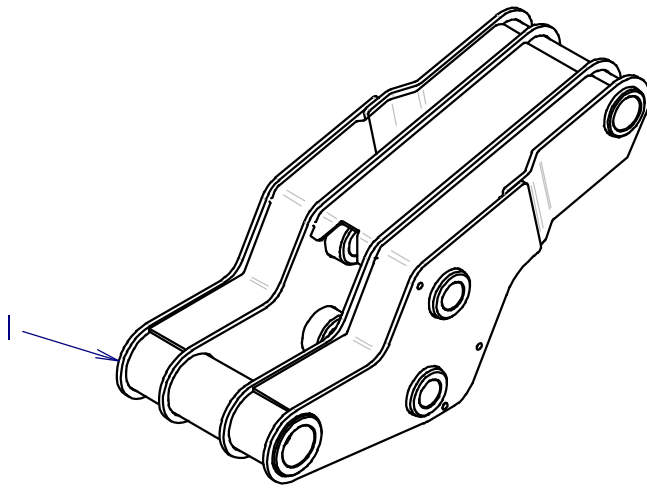
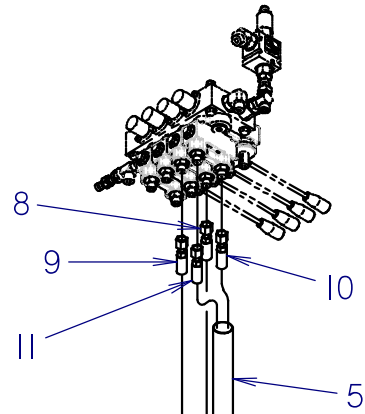
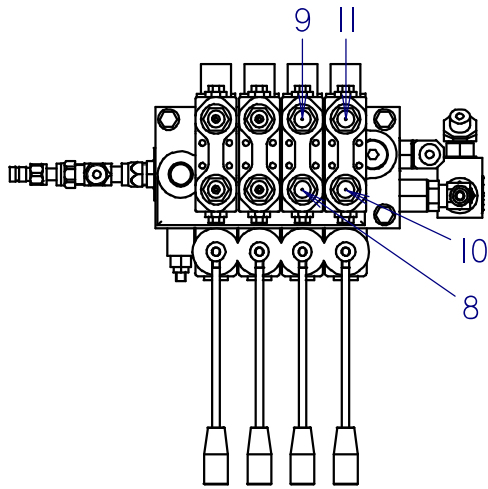

PIVOT HYDRAULICS

REF NO.	PART NUMBER	QTY	DESCRIPTION	REMARKS
1	305-874	1	LINK	
2	154-276	4	CONNECTOR (040-08S90)	
3	117-670	1	ABRASION SLEEVE (1" X 10")	
4	116-642	1	ABRASION SLEEVE (1.25" X 140")	
5	117-281	1	ABRASION SLEEVE (1.25" X 122")	
6	149-698	1	CYL (4.0 X 2.00 X 4.0)	
7	150-2047	1	CYL (4.0 X 2.00 X 4.50)	
8	150-1581	1	HOSE (040FX-157"-4000)	
9	150-1582	1	HOSE (040FX-150"-4000)	
10	150-1583	1	HOSE (040FX-126"-4000)	
11	150-1584	1	HOSE (040FX-124"-4000)	

NOT SHOWN:

FOOTNOTES:

NOTE:

STABILIZER HYDRAULICS

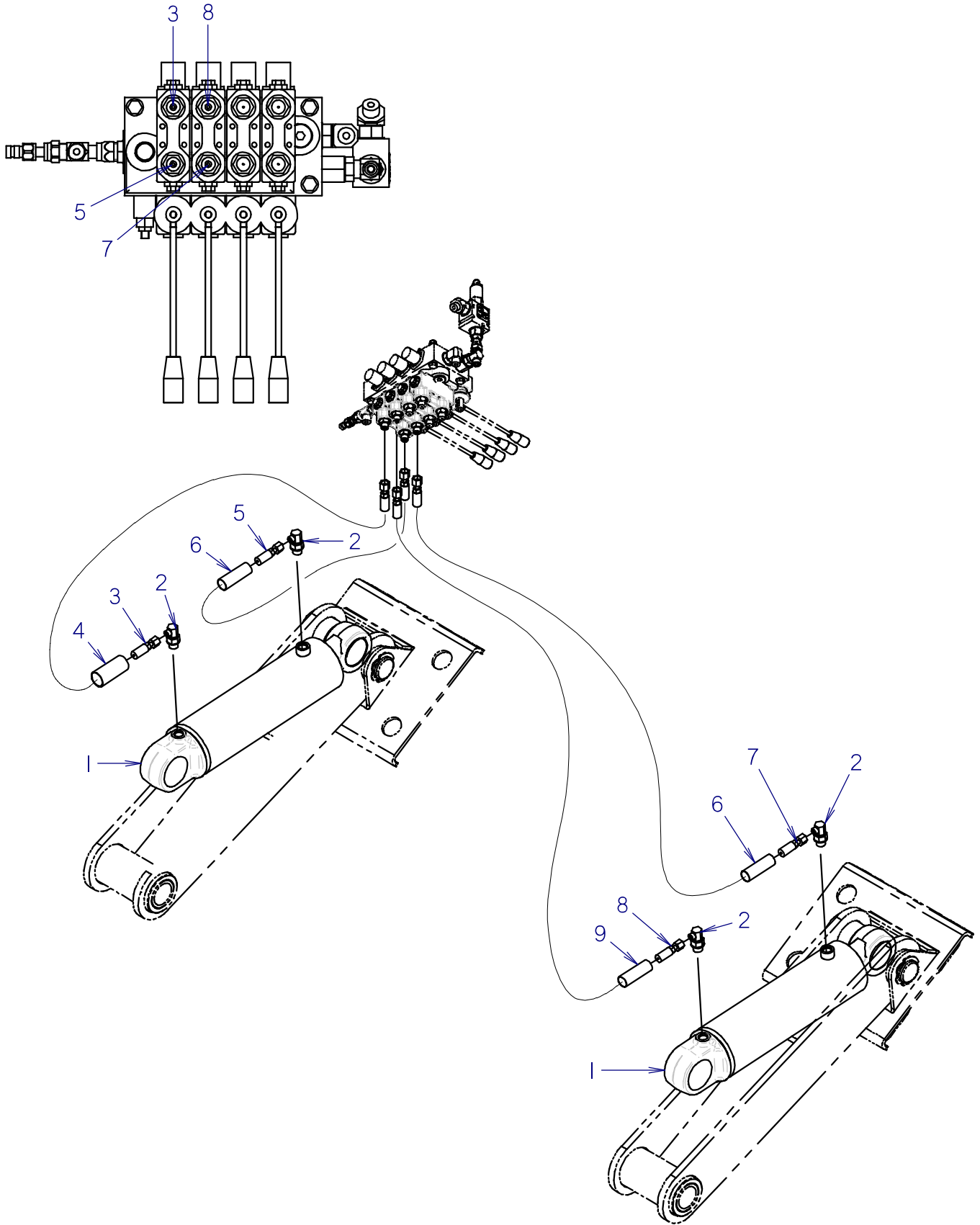

STABILIZER HYDRAULICS

REF NO.	PART NUMBER	QTY	DESCRIPTION	REMARKS
1	151-088	2	CYL (4.0 X 2.00 X 12.0)	
2	154-276	4	CONNECTOR (040-08S90)	
3	150-1577	1	HOSE (040FX-44"-4000)	
4	117-323	1	ABRASION SLEEVE (1.25" X 37")	
5	150-1578	1	HOSE (040FX-60"-4000)	
6	117-672	2	ABRASION SLEEVE (1.00" X 20")	
7	150-1580	1	HOSE (040FX-109"-4000)	
8	150-1579	1	HOSE (040FX-94"-4000)	
9	117-390	1	ABRASION SLEEVE (1.25" X 85")	

NOT SHOWN:

FOOTNOTES:

NOTE:

WRENCH MANIFOLD

(JT3020)-ENDS WITH S/N: CMWJ30M1V90000298

(AT3020)-ENDS WITH S/N: CMWJ30ATL90000178

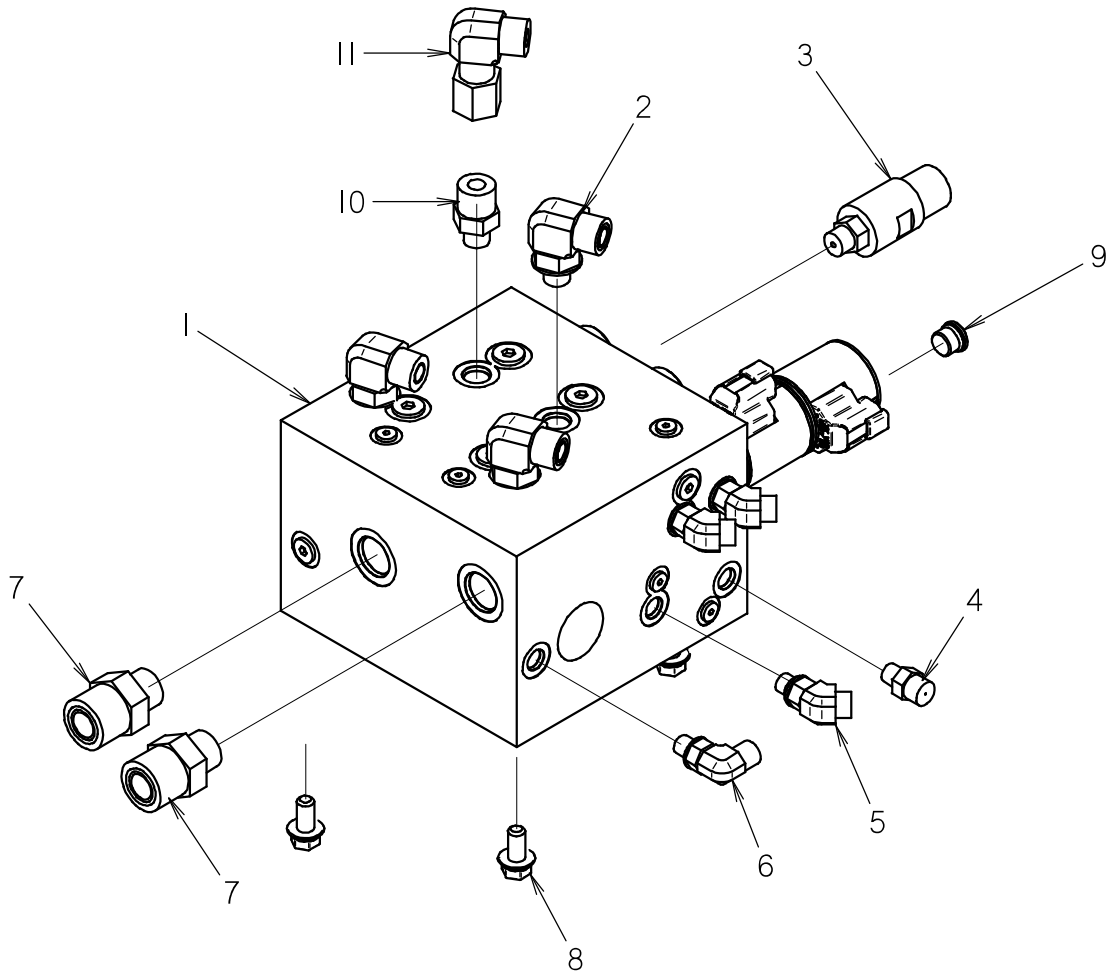

WRENCH MANIFOLD

(JT3020)-ENDS WITH S/N: CMWJ30M1V90000298

(AT3020)-ENDS WITH S/N: CMWJ30ATL90000178

REF NO.	PART NUMBER	QTY	DESCRIPTION	REMARKS
1	I50-I610	1	HYDRAULIC MANIFOLD	SEE FOOTNOTE I
2	I54-253	3	CONNECTOR (06S-08090)	
3	215-1121	1	PRESSURE SWITCH	
4	I57-286	1	CONNECTOR (04S-040, ORF .028)	
5	I54-263	3	CONNECTOR (04S-04045)	
6	I54-252	1	CONNECTOR (04S-04090)	
7	I54-247	2	CONNECTOR (10S-120)	
8	I05-825	4	FLG LK BOLT (3/8-NC X 3/4)	
9	I54-384	1	PLUG (06S)	
10	I54-246	1	CONNECTOR (06S-080)	
11	I54-256	1	UNION (080-080FX90)	

NOT SHOWN:

FOOTNOTES:

- | | | |
|-------------|------------------------------------|-------------------|
| I. 150-1877 | SOLENOID VALVE, 3W2P | |
| 500-1416 | SEAL REPAIR KIT | USE WITH 150-1877 |
| 500-1311 | SOLENOID COIL, 12VDC W/ZENER DIODE | USE WITH 150-1877 |
| 150-1878 | SOLENOID VALVE, 4W3P | |
| 500-1417 | SEAL REPAIR KIT | USE WITH 150-1878 |
| 500-1330 | SOLENOID COIL, 12VDC W/ZENER DIODE | USE WITH 150-1878 |
| 150-1879 | PILOT VALVE, 4W2P | |
| 500-1418 | SEAL REPAIR KIT | USE WITH 150-1879 |

NOTE:

WRENCH MANIFOLD

(JT3020)-BEGINS WITH S/N: CMWJ30M1A90000299

(AT3020)-BEGINS WITH S/N: CMWJ30ATH90000179

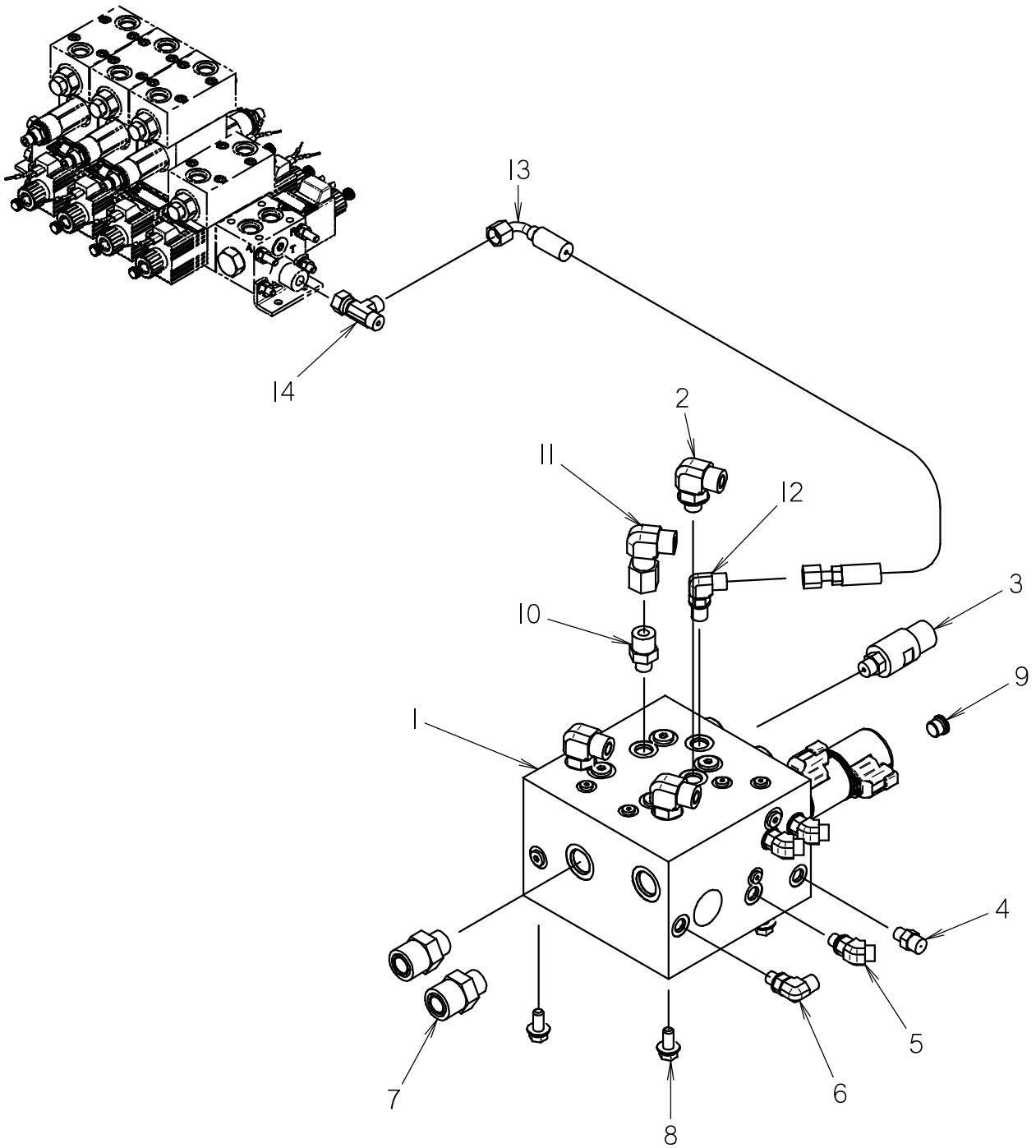

WRENCH MANIFOLD

(JT3020)-BEGINS WITH S/N: CMWJ30M1A90000299

(AT3020)-BEGINS WITH S/N: CMWJ30ATH90000179

REF NO.	PART NUMBER	QTY	DESCRIPTION	REMARKS
1	150-2989	1	HYDRAULIC MANIFOLD	
2	154-253	3	CONNECTOR (06S-08090)	
3	215-1121	1	PRESSURE SWITCH	
4	157-286	1	CONNECTOR (04S-040, ORF .028)	
5	154-263	3	CONNECTOR (04S-04045)	
6	154-252	1	CONNECTOR (04S-04090)	
7	154-247	2	CONNECTOR (10S-120)	
8	105-825	3	FLG LK BOLT (3/8-NC X 3/4)	
9	154-384	1	PLUG (06S)	
10	154-246	1	CONNECTOR (06S-080)	
11	154-256	1	UNION (080-080FX90)	
12	154-226	1	CONNECTOR (040-06S90)	
13	515-074	1	HOSE (040FX90S-77"-3000)	
14	154-265	1	UNION RUN TEE (040FX-040-040)	

NOT SHOWN:

150-1877 SOLENOID VALVE, 3W2P
 150-1878 SOLENOID VALVE, 4W3P
 150-1879 PILOT VALVE, 4W2P

SEE FOOTNOTE 1
 SEE FOOTNOTE 2
 SEE FOOTNOTE 3

FOOTNOTES:

- 500-1416 SEAL REPAIR KIT
500-1311 SOLENOID COIL, 12VDC W/ZENER DIODE
- 500-1417 SEAL REPAIR KIT
500-1330 SOLENOID COIL, 12VDC W/ZENER DIODE
- 500-1418 SEAL REPAIR KIT

USE WITH 150-1877
 USE WITH 150-1877
 USE WITH 150-1878
 USE WITH 150-1878
 USE WITH 150-1879

NOTE:

WRENCH MANIFOLD HYDRAULICS

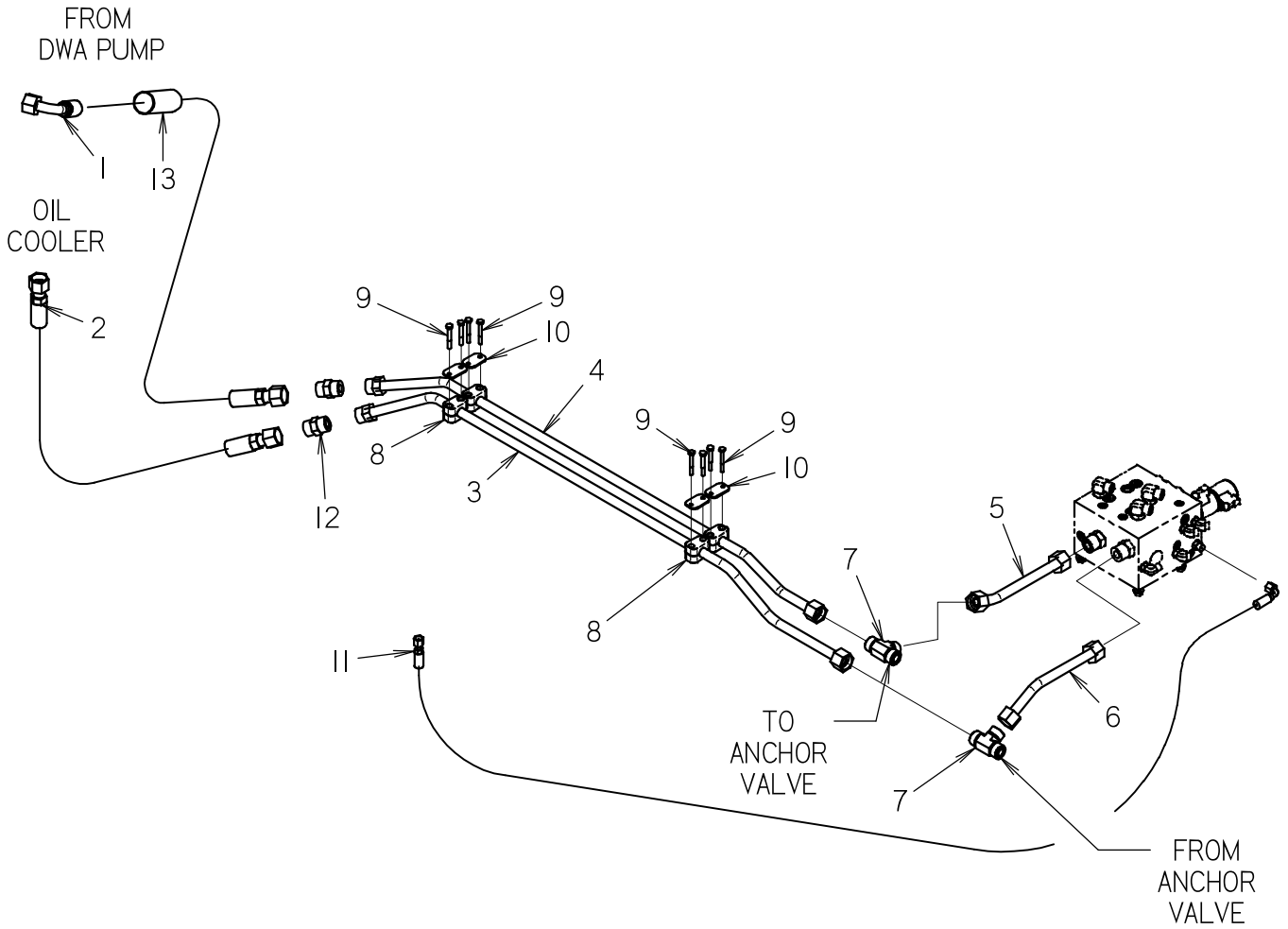

WRENCH MANIFOLD HYDRAULICS

REF NO.	PART NUMBER	QTY	DESCRIPTION	REMARKS
1	150-1568	1	HOSE (120FX90S-60"-4000)	
2	150-1569	1	HOSE (120FX-37"-4000)	
3	150-1487	1	HYDRAULIC LINE (-12)	
4	150-1486	1	HYDRAULIC LINE (-12)	
5	150-1485	1	HYDRAULIC LINE (-12)	
6	150-1484	1	HYDRAULIC LINE (-12)	
7	154-455	2	TEE (120)	
8	110-411	4	BOLT-ON CLAMP (3/4", SET)	
9	105-106	8	BOLT (1/4-NC X 2")	
10	322-289	4	BACKUP (BOLT-ON)	
11	515-277	1	HOSE (040FX90S-128"-3000)	
12	154-431	2	CONNECTOR (120-120)	
13	117-265	1	ABRASION SLEEVE (1.75" X 50.0")	

NOT SHOWN:

FOOTNOTES:

NOTE:

FRONT WRENCH HYDRAULICS

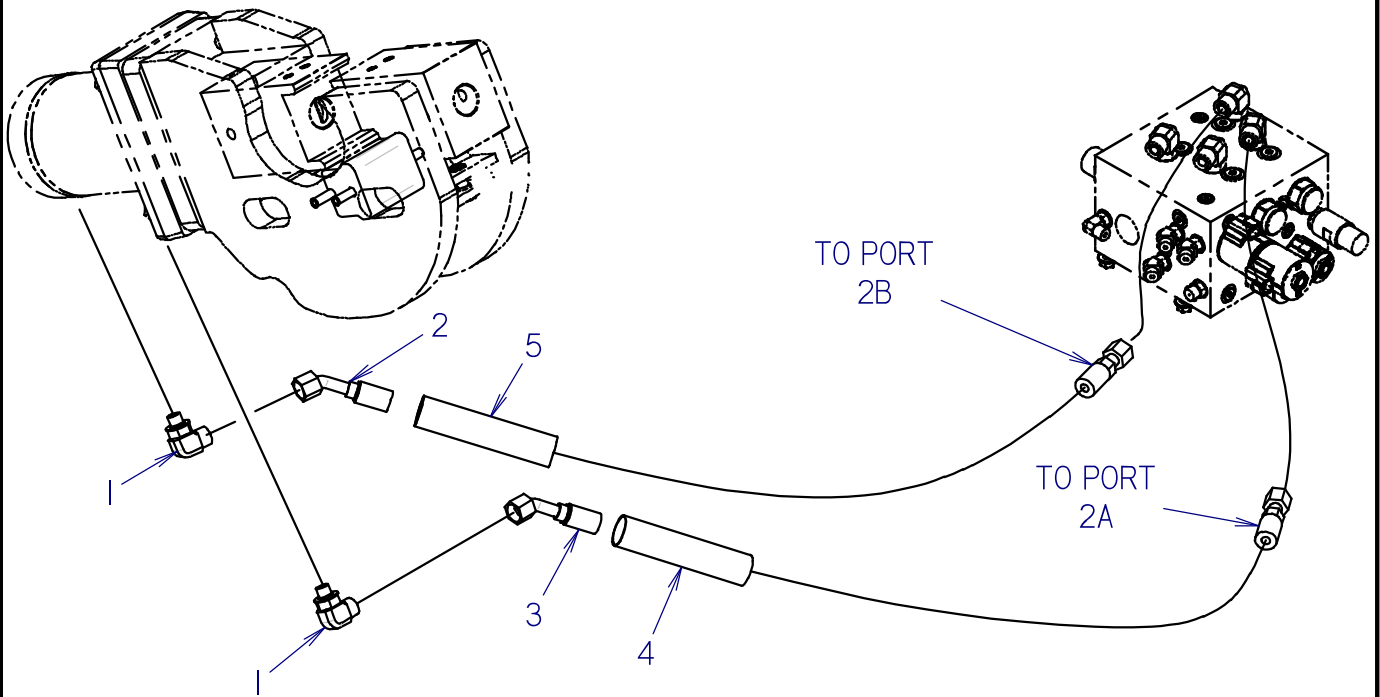

FRONT WRENCH HYDRAULICS

REF NO.	PART NUMBER	QTY	DESCRIPTION	REMARKS
1	I54-253	2	CONNECTOR (06S-08090)	
2	I50-I633	1	HOSE (080FX45-54"-4000)	
3	I50-I634	1	HOSE (080FX45-50"-4000)	
4	I17-215	1	ABRASION SLEEVE (1.25" X 46")	
5	I17-395	1	ABRASION SLEEVE (1.25" X 50")	

NOT SHOWN:

FOOTNOTES:

NOTE:

REAR WRENCH HYDRAULICS

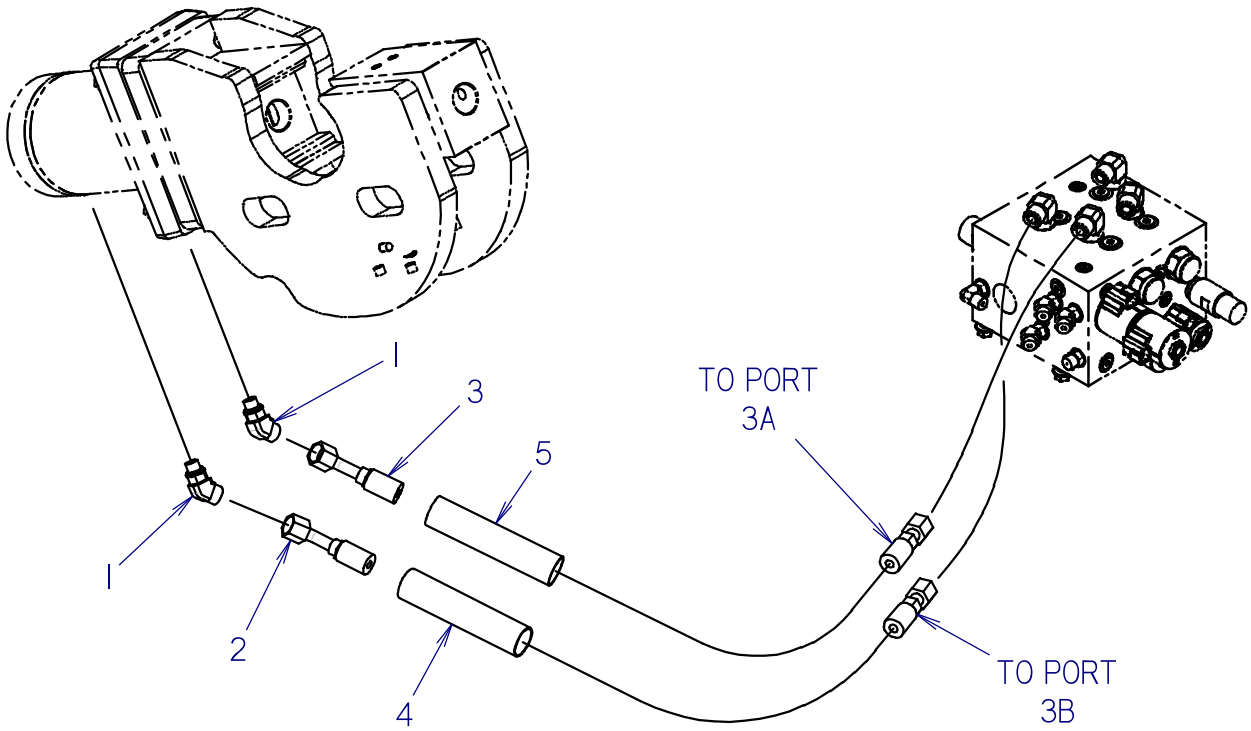

REAR WRENCH HYDRAULICS

REF NO.	PART NUMBER	QTY	DESCRIPTION	REMARKS
1	I54-283	2	CONNECTOR (06S-08045)	
2	I50-I634	1	HOSE (080FX45-50"-4000)	
3	I50-I635	1	HOSE (080FX45-47"-4000)	
4	I17-215	1	ABRASION SLEEVE (1.25" X 46")	
5	I17-388	1	ABRASION SLEEVE (1.25" X 42")	

NOT SHOWN:

FOOTNOTES:

NOTE:

WRENCH ROTATE HYDRAULICS

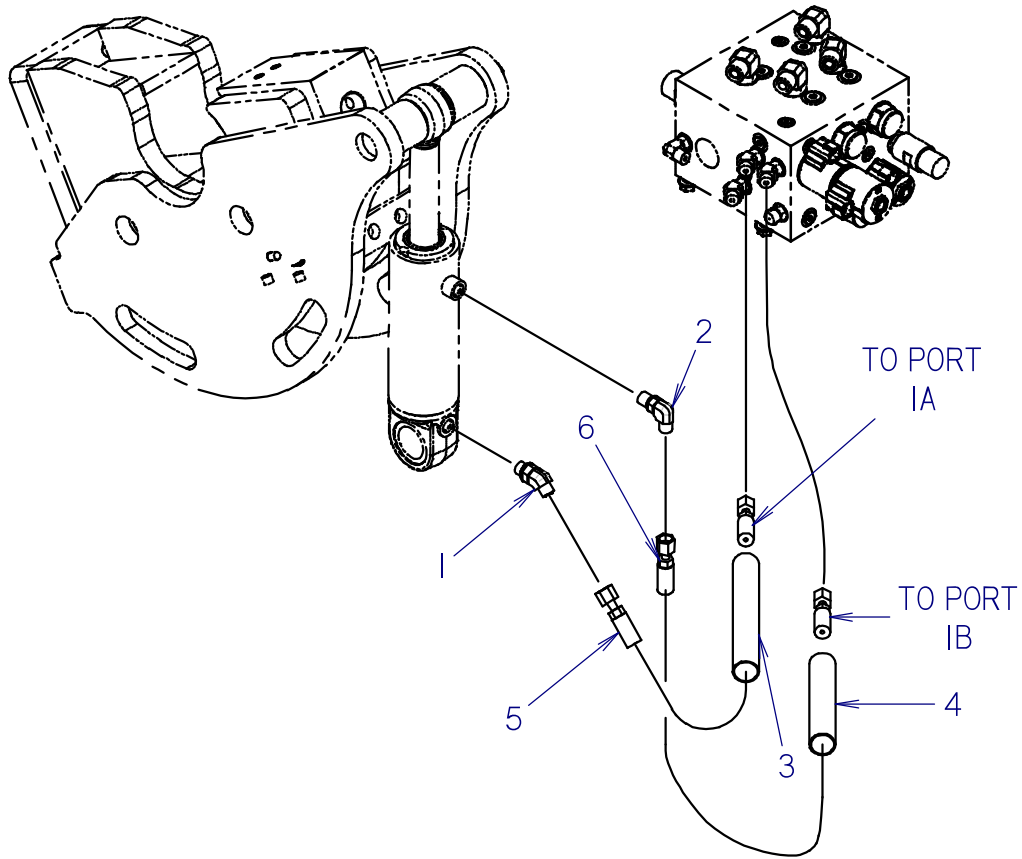

WRENCH ROTATE HYDRAULICS

REF NO.	PART NUMBER	QTY	DESCRIPTION	REMARKS
1	I54-250	1	CONNECTOR (040-06S45)	
2	I54-226	1	CONNECTOR (040-06S90)	
3	I17-607	1	ABRASION SLEEVE (1.00" X 21")	
4	I17-409	1	ABRASION SLEEVE (1.00" X 40")	
5	I54-856	1	HOSE (040FX-22"-5000)	
6	I54-889	1	HOSE (040FX-30"-5000)	

NOT SHOWN:

FOOTNOTES:

NOTE:

CENTERING CYLINDER HYDRAULICS

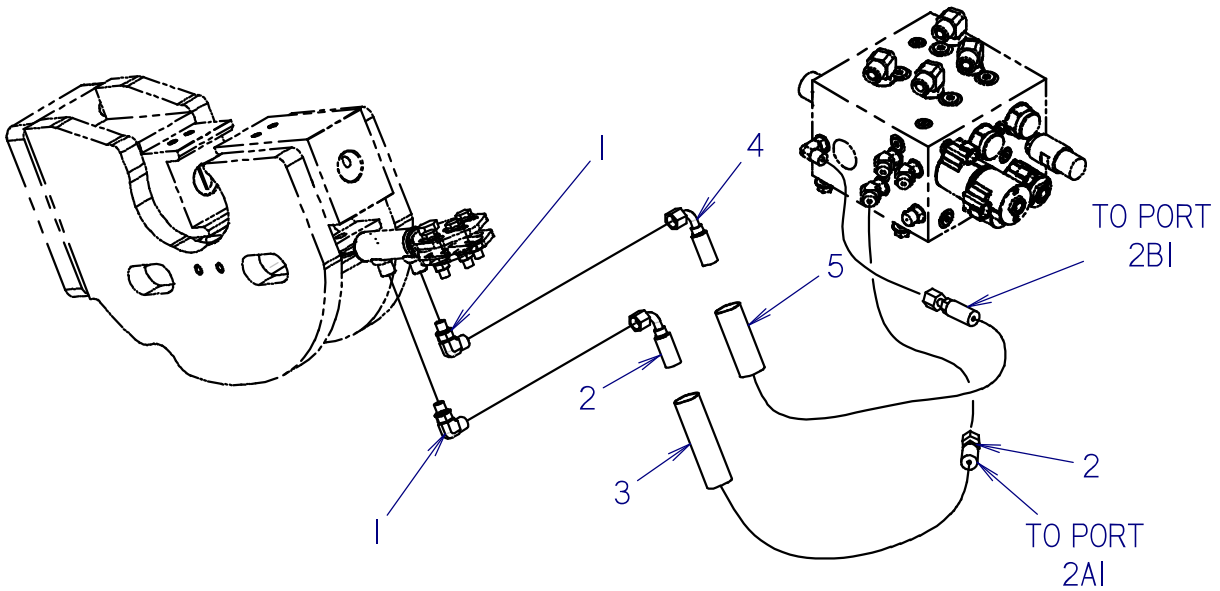

CENTERING CYLINDER HYDRAULICS

REF NO.	PART NUMBER	QTY	DESCRIPTION	REMARKS
1	I56-967	2	CONNECTOR (O4S-04090,ORF)	
2	I53-799	1	HOSE (O40FX90S-38"-5000)	
3	I17-410	1	ABRASION SLEEVE (1.00" X 38")	
4	I53-800	1	HOSE (O40FX90S-42"-5000)	
5	I17-717	1	ABRASION SLEEVE (1.00" X 40")	

NOT SHOWN:

FOOTNOTES:

NOTE:

ANCHOR VALVE
ENDS WITH S/N: _____

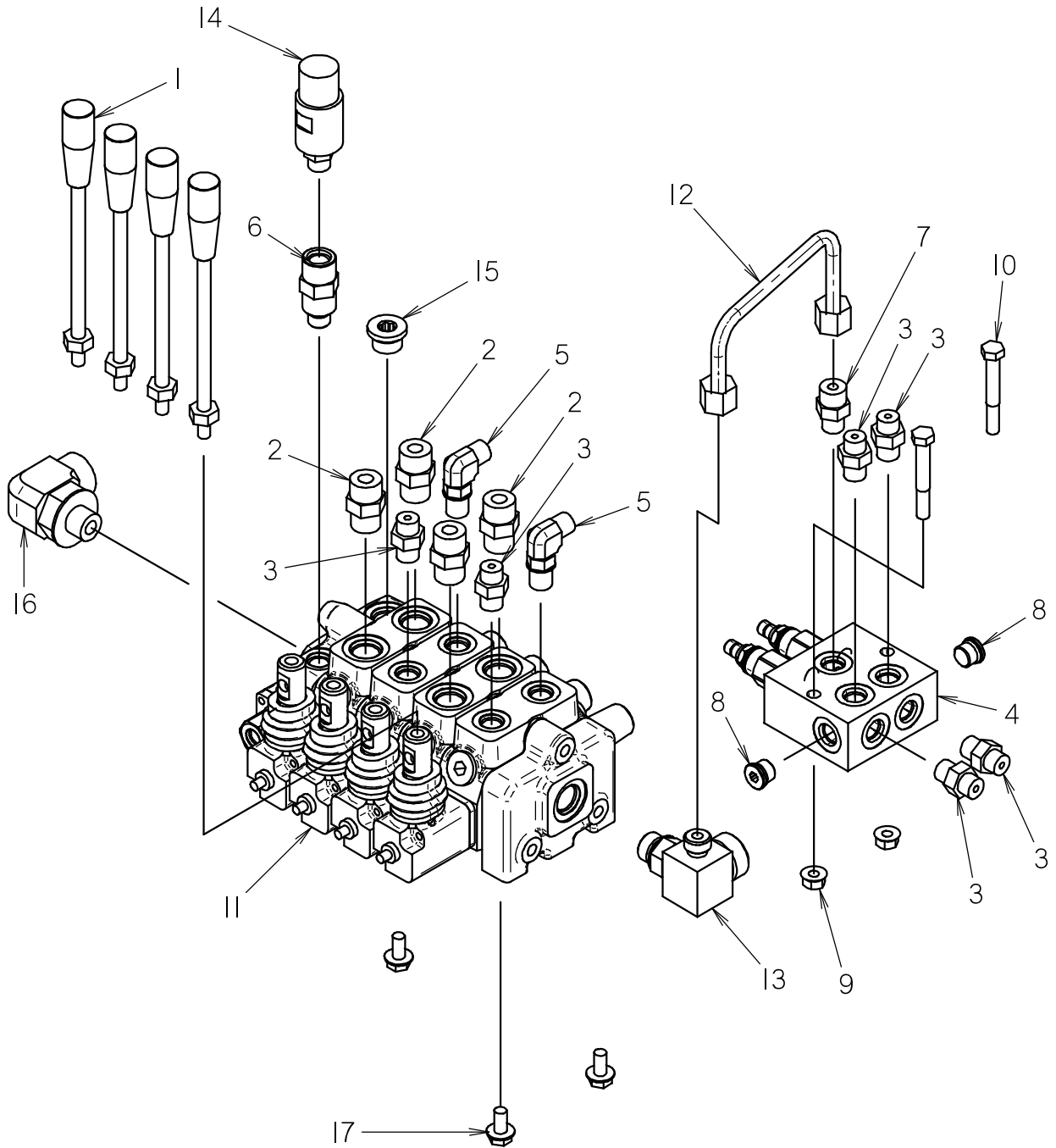

ANCHOR VALVE

ENDS WITH S/N: _____

REF NO.	PART NUMBER	QTY	DESCRIPTION	REMARKS
1	365-414	4	LEVER (M8-1.25 X 200MM)	
2	154-233	4	CONNECTOR (08S-080)	
3	154-220	6	CONNECTOR (040-06S)	
4	150-1193	1	HYDRAULIC RELIEF VALVE	SEE FOOTNOTE 1 FOR SERVICE PARTS
5	154-226	2	CONNECTOR (040-06S90)	
6	150-1212	1	CONNECTOR (-06 F-06 M)	
7	154-221	1	CONNECTOR (06S-060)	
8	154-384	2	PLUG (06S)	
9	106-386	2	FLG LOCKNUT (M8-1.25)	
10	106-570	2	SCREW (M8-1.25 X 60MM)	
11	150-1197	1	VALVE	SEE FOOTNOTE 2 FOR SERVICE PARTS, ENDS WITH S/N: _____
12	150-1493	1	HYDRAULIC LINE (-06)	
13	150-1319	1	CONNECTOR (08S-120-060 90)	
14	215-1122	1	PRESSURE SWITCH	SEE FOOTNOTE 3
15	155-074	1	PLUG (08S, SOC, FM)	
16	514-107	1	CONNECTOR (08S-12090)	
17	106-380	3	FLG LK SCREW (M8-1.25 X 16MM)	

NOT SHOWN:

FOOTNOTES:

1. 150-1452 RELIEF CARTRIDGE
2. 190-1207 SEAL KIT (I SECTION)
190-1208 RELIEF VALVE KIT
3. IF REPLACING THE 215-1122 PRESSURE SWITCH, REPLACE WITH KIT 190-1685. SEE PARTS PAGE ID0274440.

NOTE:

ANCHOR VALVE

BEGINS WITH S/N: _____

ENDS WITH S/N: _____

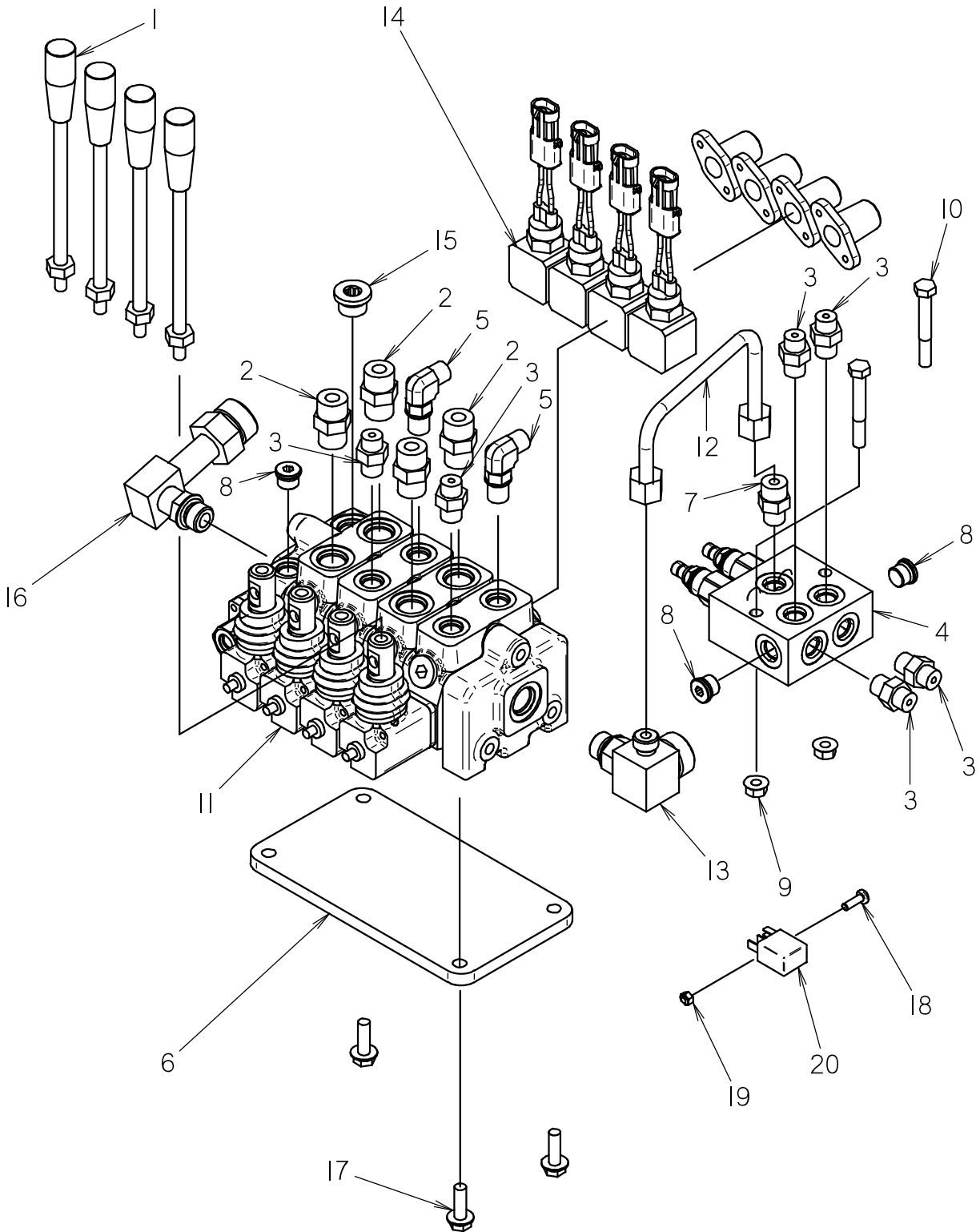

ANCHOR VALVE

BEGINS WITH S/N: _____

ENDS WITH S/N: _____

REF NO.	PART NUMBER	QTY	DESCRIPTION	REMARKS
	190-1685		JT3020 ANCHOR VALVE SWITCH KIT	INCLUDES ITEMS 6, 8, 12, 14, 16-20
1	365-414	4	LEVER (M8-1.25 X 200MM)	
2	154-233	4	CONNECTOR (08S-080)	
3	154-220	6	CONNECTOR (040-06S)	
4	150-1193	1	HYDRAULIC RELIEF VALVE	SEE FOOTNOTE 1 FOR SERVICE PARTS
5	154-226	2	CONNECTOR (040-06S90)	
6	301-1868	1	SPACER PLATE	
7	154-221	1	CONNECTOR (06S-060)	
8	154-384	3	PLUG (06S)	
9	106-386	2	FLG LOCKNUT (M8-1.25)	
10	106-570	2	SCREW (M8-1.25 X 60MM)	
11	150-1197	1	VALVE	SEE FOOTNOTE 2 FOR SERVICE PARTS, SEE FOOTNOTE 5
12	150-3298	1	HARDLINE (1-06)	
13	150-1319	1	CONNECTOR (08S-120-060 90)	
14	215-1712	4	VALVE MICROSWITCH	SEE FOOTNOTE 3
15	155-074	1	PLUG (08S, SOC, FM)	
16	159-886	1	ELBOW (08S-12090, LG)	
17	106-381	3	FLG LK SCREW (M8-1.25 X 25MM)	
18	107-684	1	SCREW (M5-0.80 X 16MM, PAN PLPS)	SEE FOOTNOTE 4
19	106-850	1	LOCKNUT (M5-0.80)	SEE FOOTNOTE 4
20	217-710	1	MICRO RELAY (SPDT)	SEE FOOTNOTE 4

NOT SHOWN:

FOOTNOTES:

- 150-1452 RELIEF CARTRIDGE
- 190-1207 SEAL KIT (I SECTION)
190-1208 RELIEF VALVE KIT
- KIT 190-1685 SUPERSEDES PRESSURE SWITCH, 215-1122.
- THE RELAY, SCREW, AND NUT MOUNT TO THE UNDERSIDE OF THE VALVE MOUNTING BRACKET ON THE FRONT RACK WELDMENT, 300-2555.
- UNITS AFTER S/N _____ USE VALVE 150-3304. SEE PARTS PAGE ID0275387. VALVE 150-1197 REQUIRES THE USE OF FRONT RACK 300-2555.

NOTE:

ANCHOR HYDRAULICS

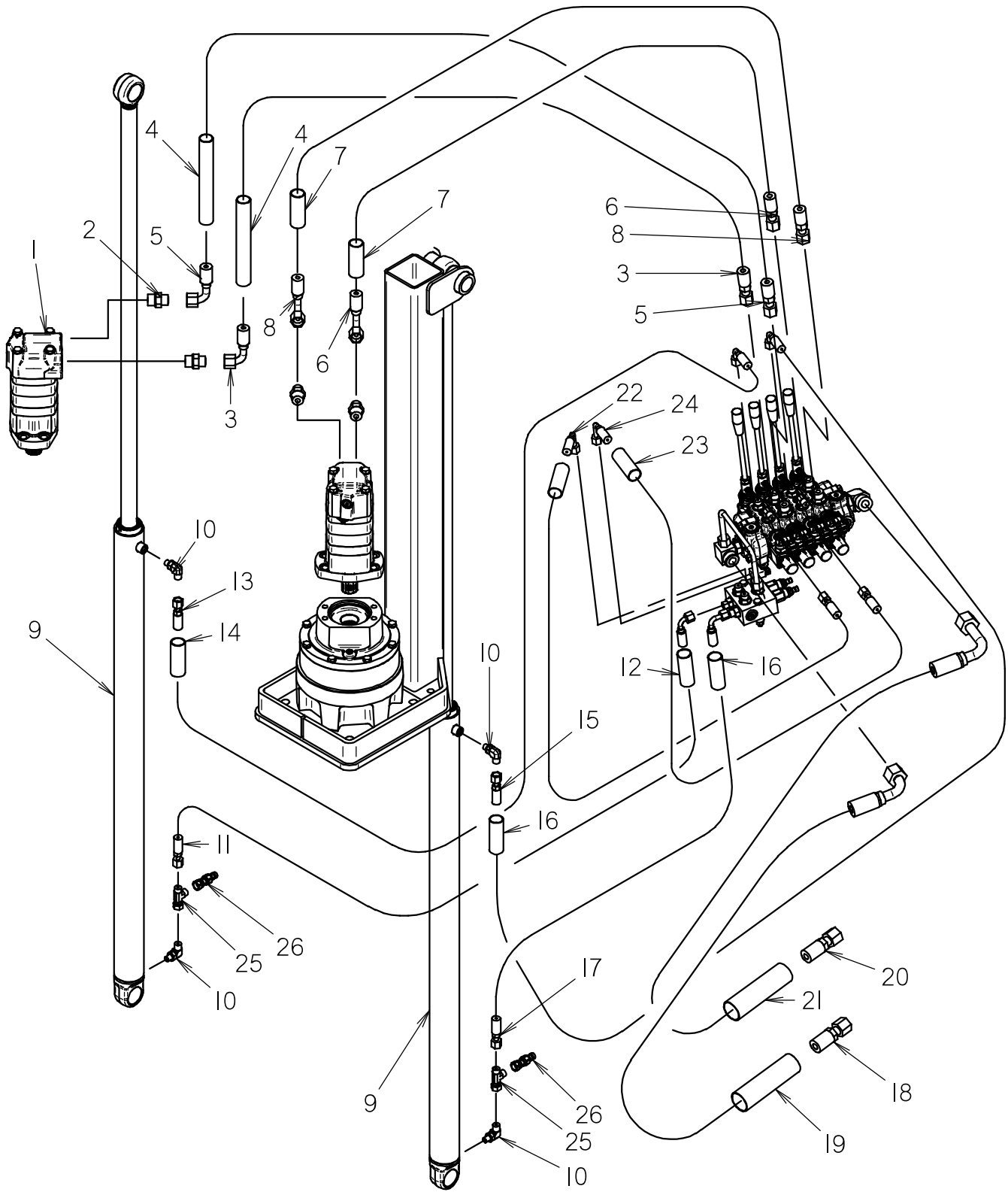

ANCHOR HYDRAULICS

REF NO.	PART NUMBER	QTY	DESCRIPTION	REMARKS
1	150-1243	2	HYD MOTOR	SEAL KIT 500-658
2	154-279	4	CONNECTOR (080-10S)	
3	150-1504	1	HOSE (080FX90S-52"-4000)	
4	117-416	2	ABRASION SLEEVE (1.00" X 50")	
5	150-1504	1	HOSE (080FX90S-52"-4000)	
6	150-1502	1	HOSE (080FX90S-60"-4000)	
7	117-326	2	ABRASION SLEEVE (1.00" X 58")	
8	150-1502	1	HOSE (080FX90S-60"-4000)	
9	150-1086	2	CYLINDER BARREL (2.0 X 40.25)	
10	154-252	4	CONNECTOR (04S-04090)	
11	150-1497	1	HOSE (040FX90S-102"-4000)	
12	117-867	1	ABRASION SLEEVE (1.00" X 100")	
13	150-1501	1	HOSE (040FX90M-153"-4000)	
14	105-1122	1	ABRASION SLEEVE (1.00" X 152")	
15	150-1496	1	HOSE (040FX90M-67"-4000)	
16	117-419	2	ABRASION SLEEVE (1.00" X 66")	
17	150-1496	1	HOSE (040FX90M-67"-4000)	
18	150-1495	1	HOSE (120FX90S-93"-4000)	
19	116-787	1	ABRASION SLEEVE (1.59" X 95")	
20	150-3340	1	HOSE (120FX90L-107"-4000)	SEE FOOTNOTE I
21	117-204	1	ABRASION SLEEVE (1.59" X 108")	
22	150-1499	1	HOSE (040FX90L-15"-4000)	
23	117-278	2	ABRASION SLEEVE (1.00" X 14")	
24	150-1498	1	HOSE (040FX90L-14"-4000)	
25	154-265	2	UNION RUN TEE (040FX-040-040)	
26	159-156	2	QDC ADAPTER (02-040F)	INCLUDES 159-148 DUST CAP

NOT SHOWN:

FOOTNOTES:

I. HOSE 150-3340 IS USED WITH VALVE 150-3304. USE HOSE 150-1494 WITH VALVE 150-1197.

NOTE:

PIPE LOADER VALVE

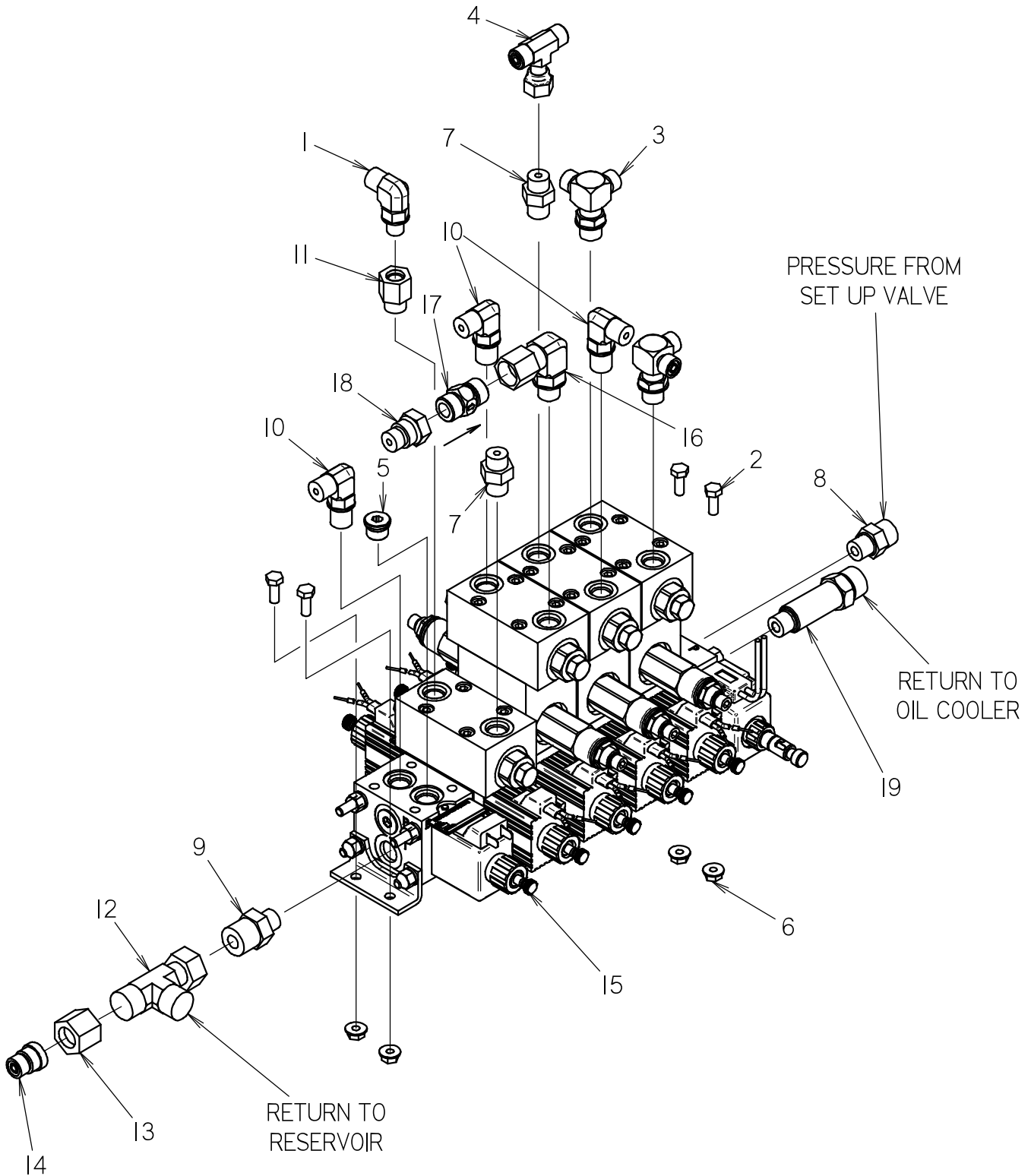

PIPE LOADER VALVE

REF NO.	PART NUMBER	QTY	DESCRIPTION	REMARKS
1	154-401	1	CONNECTOR (04S-04090, ORF)	
2	106-231	4	SCREW (M6-1.00 X 16MM)	
3	154-230	2	BRANCH TEE (06S-040-040)	
4	154-379	1	UN BR TEE (040FX-040-040)	
5	154-384	1	PLUG (06S)	
6	106-385	4	FLG LOCKNUT (M6-1.00)	
7	154-220	2	CONNECTOR (040-06S)	
8	154-221	1	CONNECTOR (06S-060)	
9	154-246	1	CONNECTOR (06S-080)	
10	154-226	3	CONNECTOR (040-06S90)	
11	155-254	1	REDUCER (06S-04SF)	
12	154-266	1	UNION RUN TEE (080FX-080-080)	
13	154-272	1	REDUCER NUT (080F)	
14	154-248	1	REDUCER STEM (040)	
15	150-1279	1	HYDRAULIC VALVE	SEE FOOTNOTE 1 FOR SERVICE PARTS
16	154-343	1	UNION (06S-060FX90)	
17	150-1852	1	FLOW CHECK VALVE (086" ORF)	
18	154-373	1	REDUCER (040-060F)	
19	150-2673	1	CONNECTOR (06S-080 SPECIAL)	

NOT SHOWN:

FOOTNOTES:

- | | | |
|-------------|-----------------------------|-------------------|
| 1. 500-1036 | BV06 CONTROL VALVE SECTION | |
| 217-948 | COIL 12VDC | USE WITH 500-1036 |
| 500-1034 | UNLOADING INLET SUBASSEMBLY | |
| 500-1092 | 1/2" UNICOIL, W/DIODE & W/P | USE WITH 500-1034 |
| 502-102 | 100 PSI DUAL PO CHECK | |
| 150-1280 | RELIEF VALVE | DUAL CROSSOVER |

NOTE:

PIPELOADER VALVE HYDRAULICS

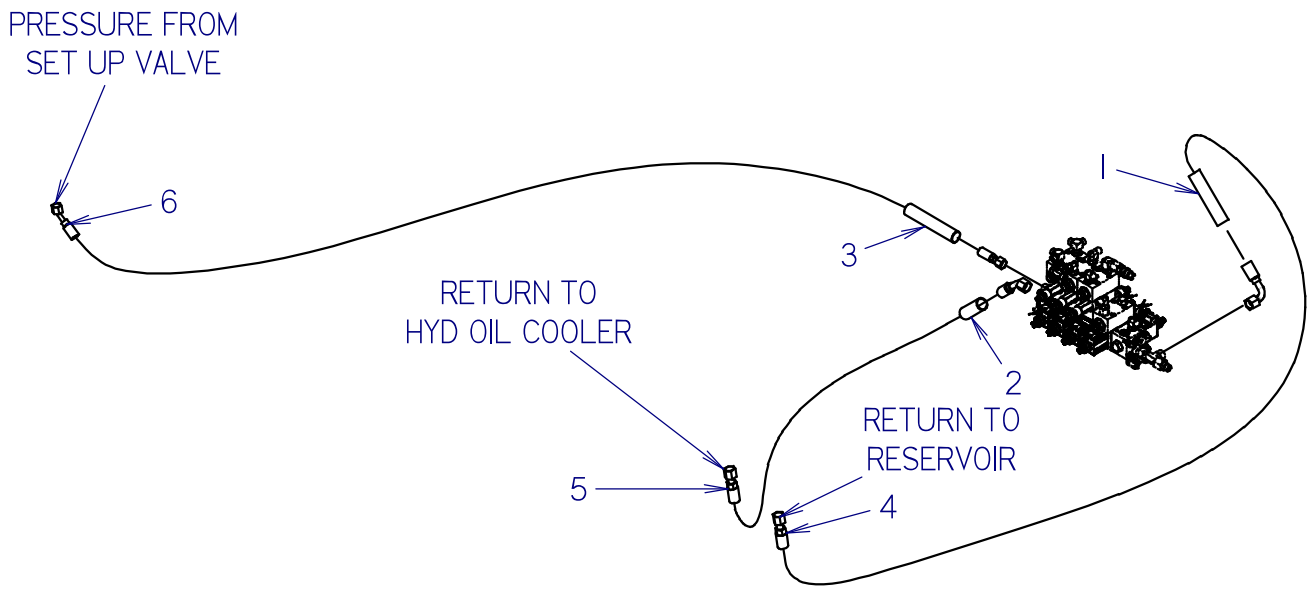

PIPELOADER VALVE HYDRAULICS

REF NO.	PART NUMBER	QTY	DESCRIPTION	REMARKS
1	105-1051	1	ABRASION SLEEVE (1.00 X 92")	
2	105-1170	1	ABRASION SLEEVE (1.00 X 70")	
3	117-841	1	ABRASION SLEEVE (1.00" X 164")	
4	515-745	1	HOSE 1080FX90M-94"-3000)	
5	150-1687	1	HOSE 1080FX45-72"-3000)	
6	150-1688	1	HOSE 1060FX45-163"-3000)	

NOT SHOWN:

FOOTNOTES:

NOTE:

GRIPPER HYDRAULICS

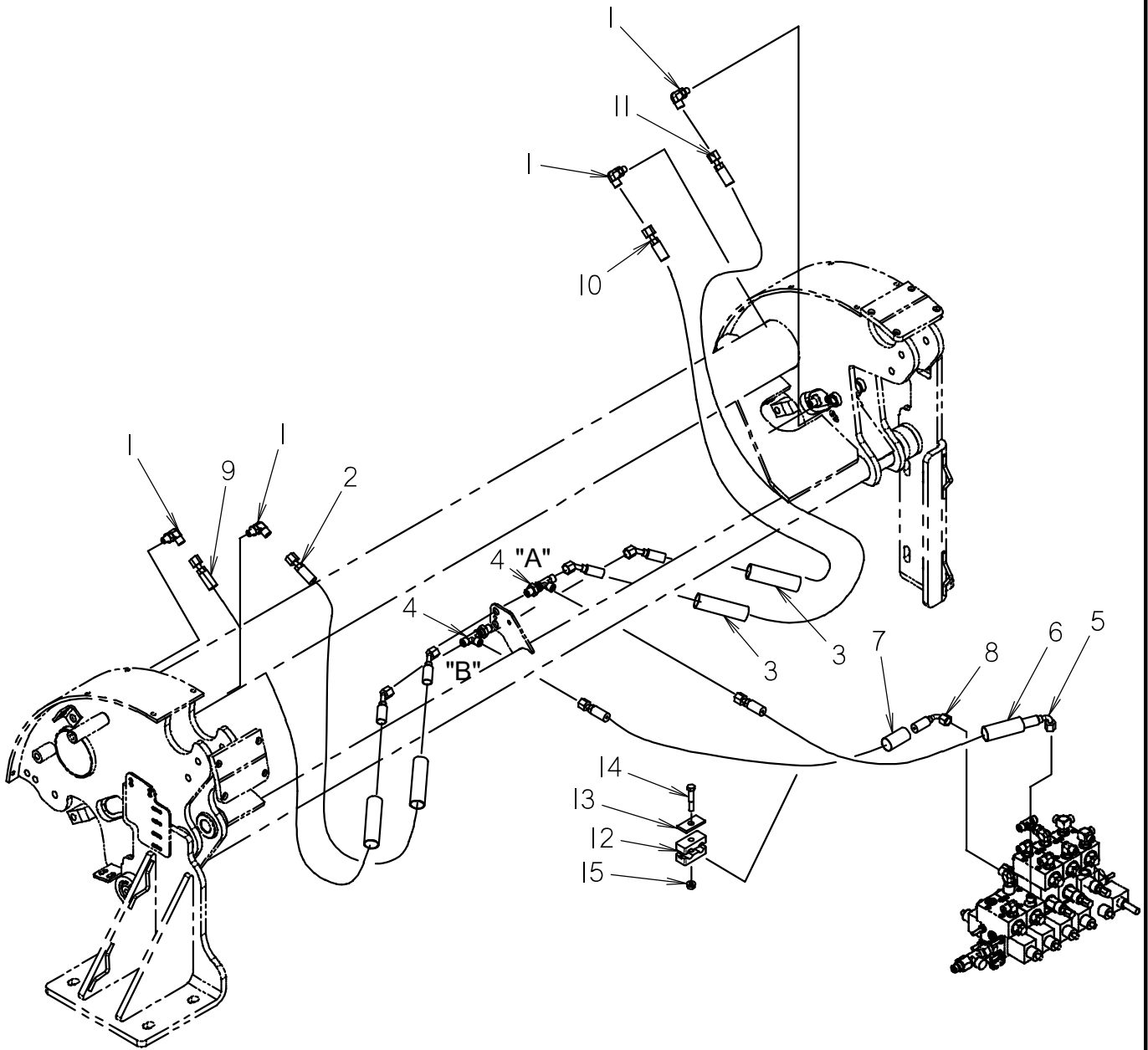

"A" = BARREL END
 "B" = ROD END

GRIPPER HYDRAULICS

REF NO.	PART NUMBER	QTY	DESCRIPTION	REMARKS
1	154-252	4	CONNECTOR (04S-04090)	
2	515-156	1	HOSE (040FX45-40"-3000)	
3	117-410	4	ABRASION SLEEVE (1.00" X 38")	
4	154-424	2	BK RUN TEE (040-040-040BK)	
5	149-362	1	HOSE (040FX90S-46"-3000)	
6	117-621	1	ABRASION SLEEVE (1.00" X 45")	
7	117-612	1	ABRASION SLEEVE (1.00" X 46")	
8	515-447	1	HOSE (040FX90S-48"-3000)	
9	515-156	1	HOSE (040FX45-40"-3000)	
10	515-156	1	HOSE (040FX45-40"-3000)	
11	515-156	1	HOSE (040FX45-40"-3000)	
12	110-270	2	BOLT-ON CLAMP (9/16", HALF)	
13	305-256	1	BACKUP SPACER	
14	106-329	1	SCREW (M8-1.25 X 50MM)	
15	106-386	1	FLG LOCKNUT (M8-1.25)	

NOT SHOWN:

FOOTNOTES:

NOTE:

SHUTTLE HYDRAULICS

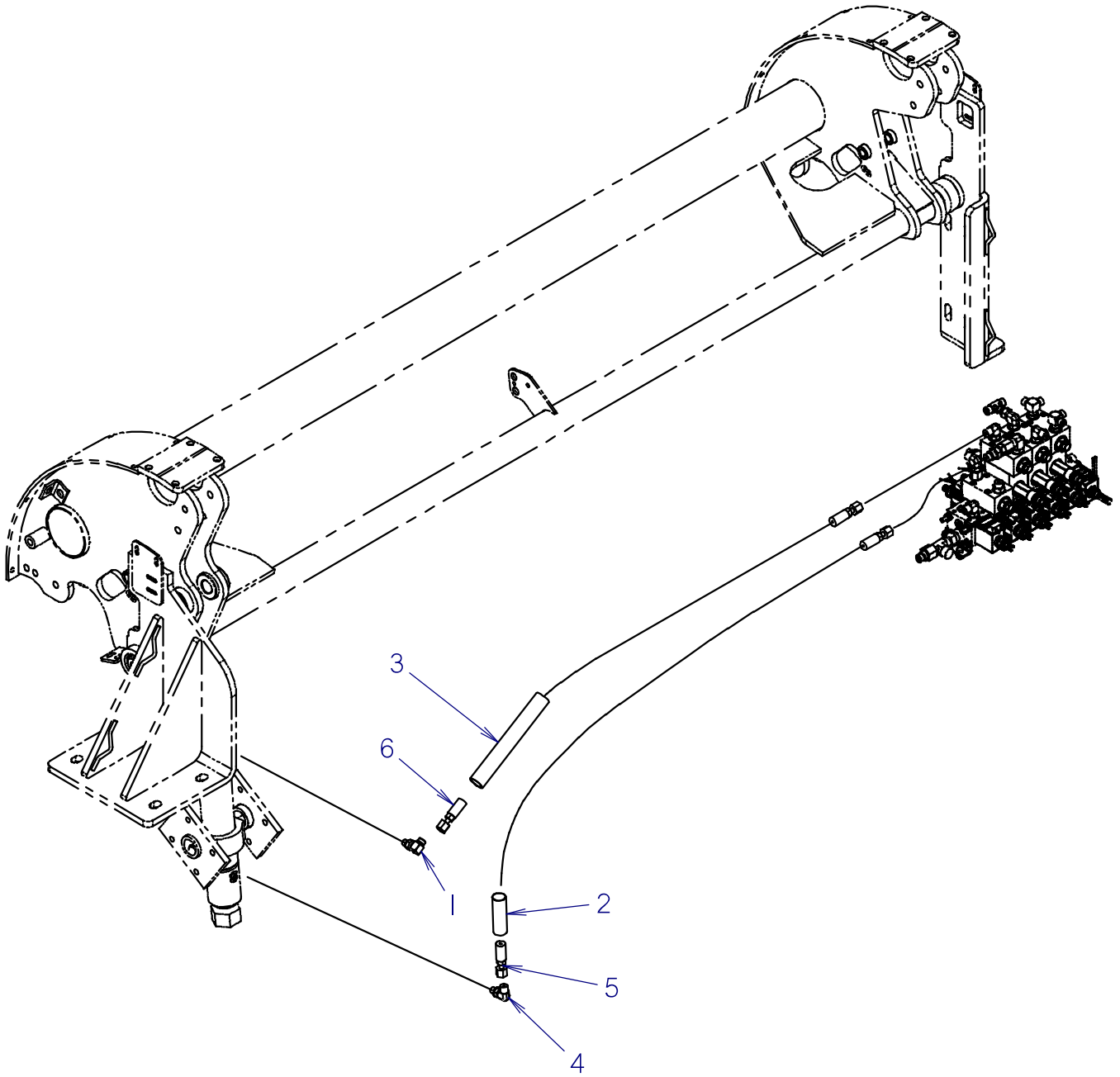

SHUTTLE HYDRAULICS

REF NO.	PART NUMBER	QTY	DESCRIPTION	REMARKS
1	150-1524	1	CONNECTOR (04S-04090,ORF)	
2	117-702	1	ABRASION SLEEVE (1.00" X 68")	
3	117-613	1	ABRASION SLEEVE (1.00" X 64")	
4	154-252	1	CONNECTOR (04S-04090)	
5	154-670	1	HOSE (040FX-70"-3000)	
6	149-914	1	HOSE (040FX-65"-3000-AR)	

NOT SHOWN:

FOOTNOTES:

NOTE:

PIPE LIFT HYDRAULICS

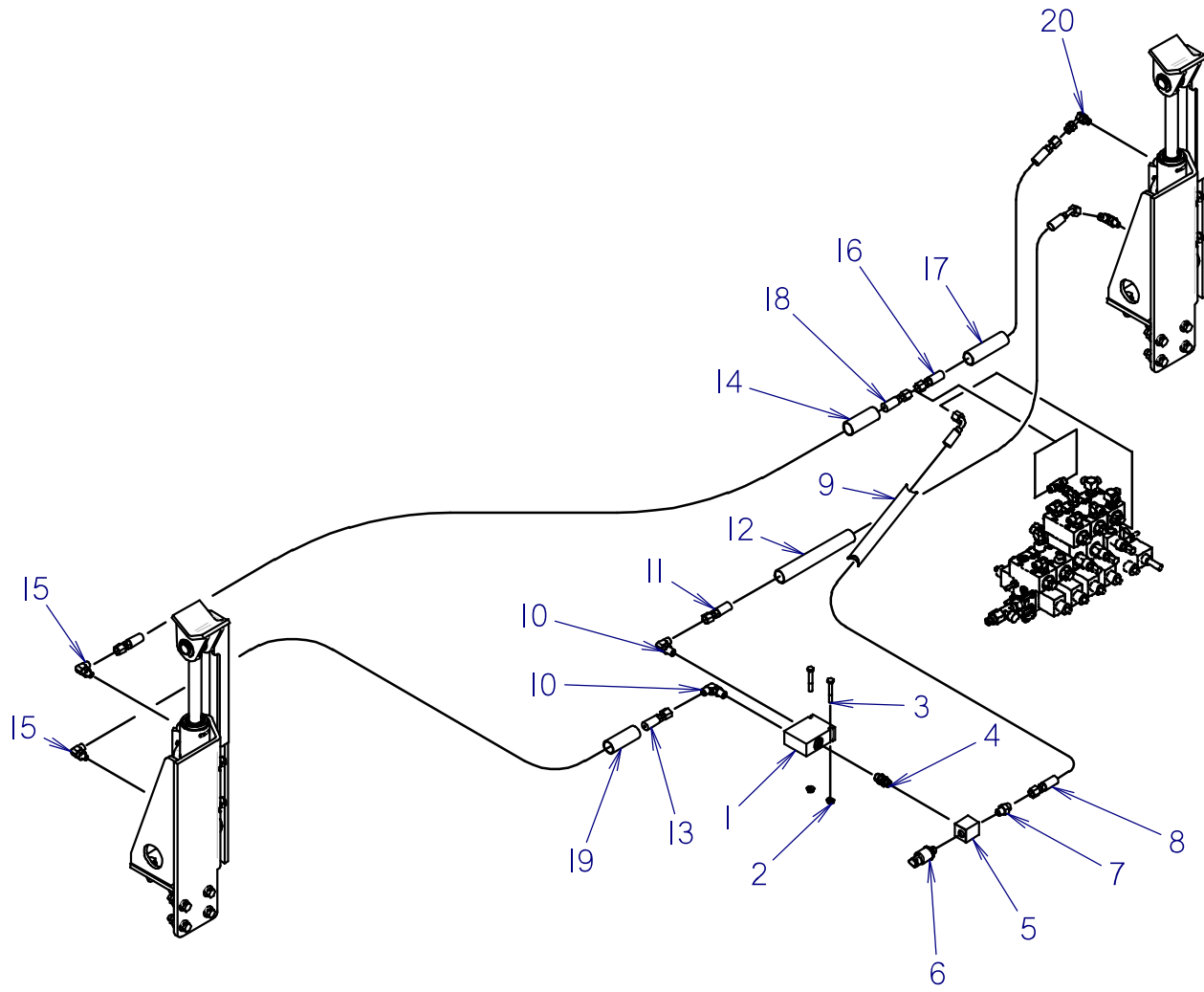

PIPE LIFT HYDRAULICS

REF NO.	PART NUMBER	QTY	DESCRIPTION	REMARKS
1	516-087	1	FLOW DIVIDER	
2	105-832	2	FLG LOCKNUT (1/4-NC)	
3	105-106	2	BOLT (1/4-NC X 2")	
4	155-153	1	CONNECTOR (06S-06S)	
5	150-1206	1	TEE (06SF-06SF-06SF)	
6	215-1245	1	PRESSURE SWITCH	1600 PSI
7	154-220	1	CONNECTOR (040-06S)	
8	153-365	1	HOSE (040FX90S-34"-3000)	
9	117-412	1	ABRASION SLEEVE (1.00" X 34")	
10	154-226	2	CONNECTOR (040-06S90)	
11	154-730	1	HOSE (040FX45-66"-3000)	
12	117-613	1	ABRASION SLEEVE (1.00" X 64")	
13	515-283	1	HOSE (040FX45-62"-3000)	
14	117-213	1	ABRASION SLEEVE (1.00" X 96")	
15	154-252	3	CONNECTOR (04S-04090)	
16	154-653	1	HOSE (040FX-40"-3000)	
17	117-410	1	ABRASION SLEEVE (1.00" X 38")	
18	154-694	1	HOSE (040FX-98"-3000)	
19	117-693	1	ABRASION SLEEVE (1.00" X 60")	
20	150-1528	1	CONNECTOR (04S-04090,SPECIAL)	

NOT SHOWN:

FOOTNOTES:

NOTE:

PIPEBOX SHUTTLE HYDRAULICS

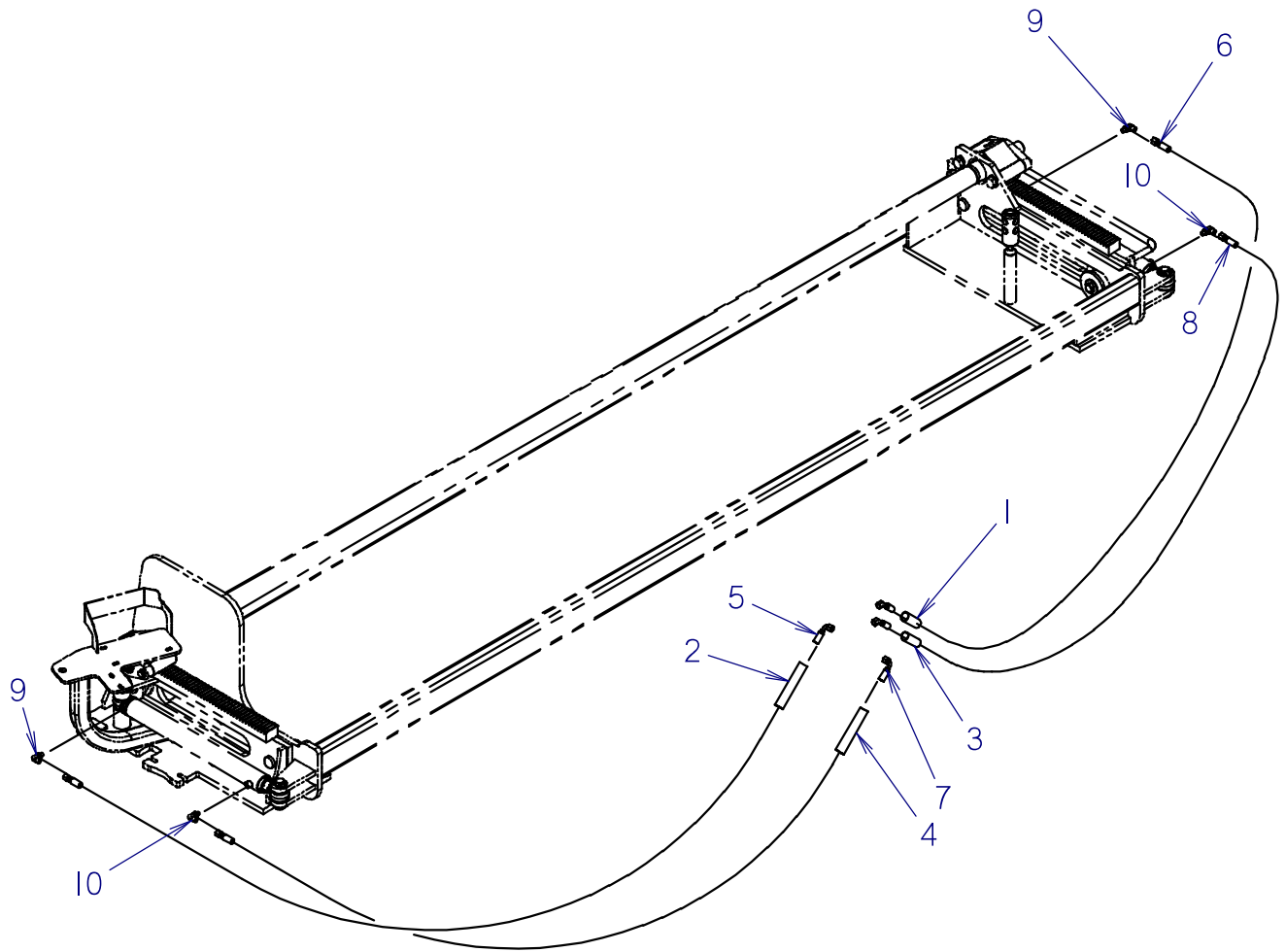

PIPEBOX SHUTTLE HYDRAULICS

REF NO.	PART NUMBER	QTY	DESCRIPTION	REMARKS
1	117-867	1	ABRASION SLEEVE (1.00" X 100")	
2	117-999	1	ABRASION SLEEVE (1.00" X 154")	
3	117-413	1	ABRASION SLEEVE (1.00" X 84")	
4	117-399	1	ABRASION SLEEVE (1.00" X 130")	
5	150-1662	1	HOSE (040FX90S-155"-3000)	
6	150-1663	1	HOSE (040FX45-105"-3000)	
7	150-1664	1	HOSE (040FX90S-135"-3000)	
8	150-1665	1	HOSE (040FX45-85"-3000)	
9	154-401	2	CONNECTOR (04S-04090, ORF)	
10	154-252	2	CONNECTOR (04S-04090)	

NOT SHOWN:

FOOTNOTES:

NOTE:

SPINDLE BRAKE HYDRAULICS

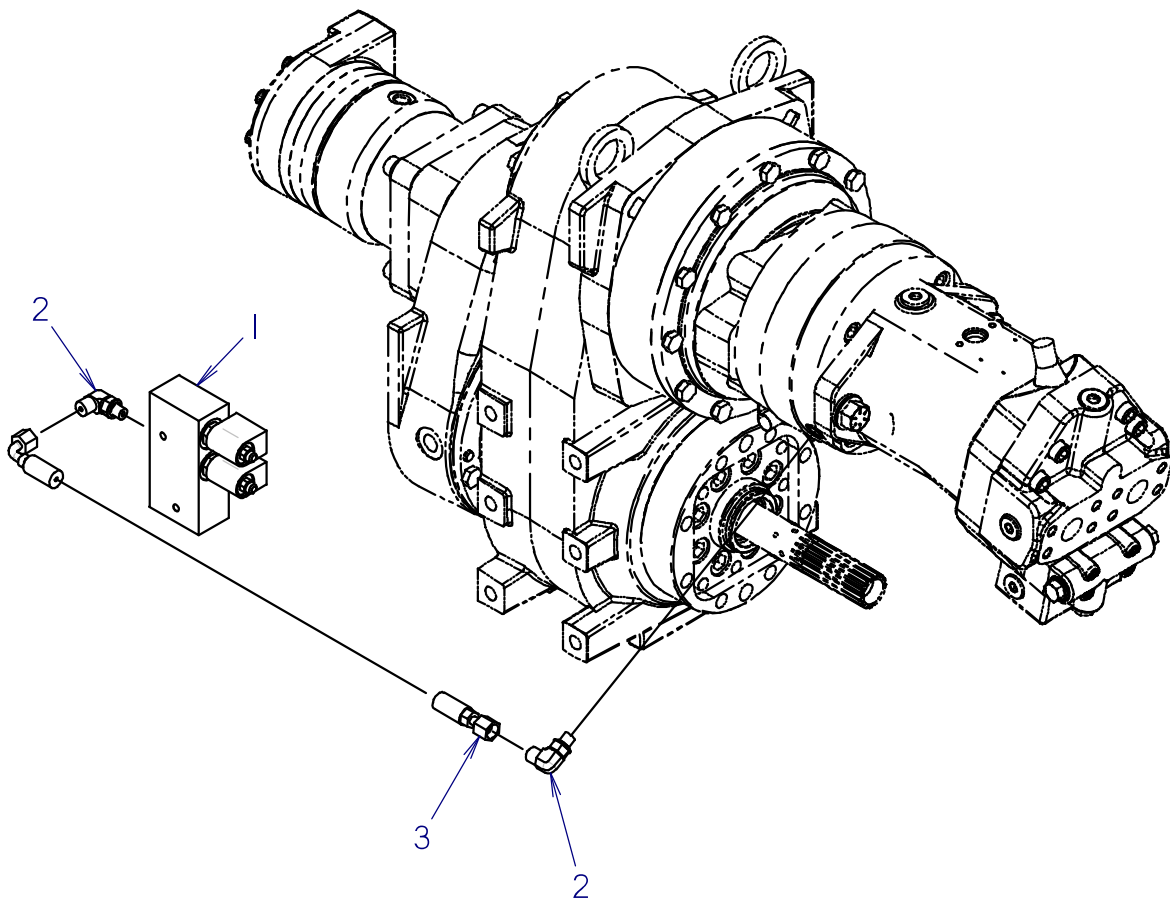

SPINDLE BRAKE HYDRAULICS

REF NO.	PART NUMBER	QTY	DESCRIPTION	REMARKS
1	I57-246	1	MANIFOLD (2-SPI)	
2	I54-252	2	CONNECTOR (04S-04090)	
3	515-744	1	HOSE (040FX90S-28"-3000)	

NOT SHOWN:

FOOTNOTES:

NOTE:

FLUID PUMP HYDRAULICS

ENDS WITH S/N: JT-CMW30M1C80000131, AT-CMWJ30ATC80000062

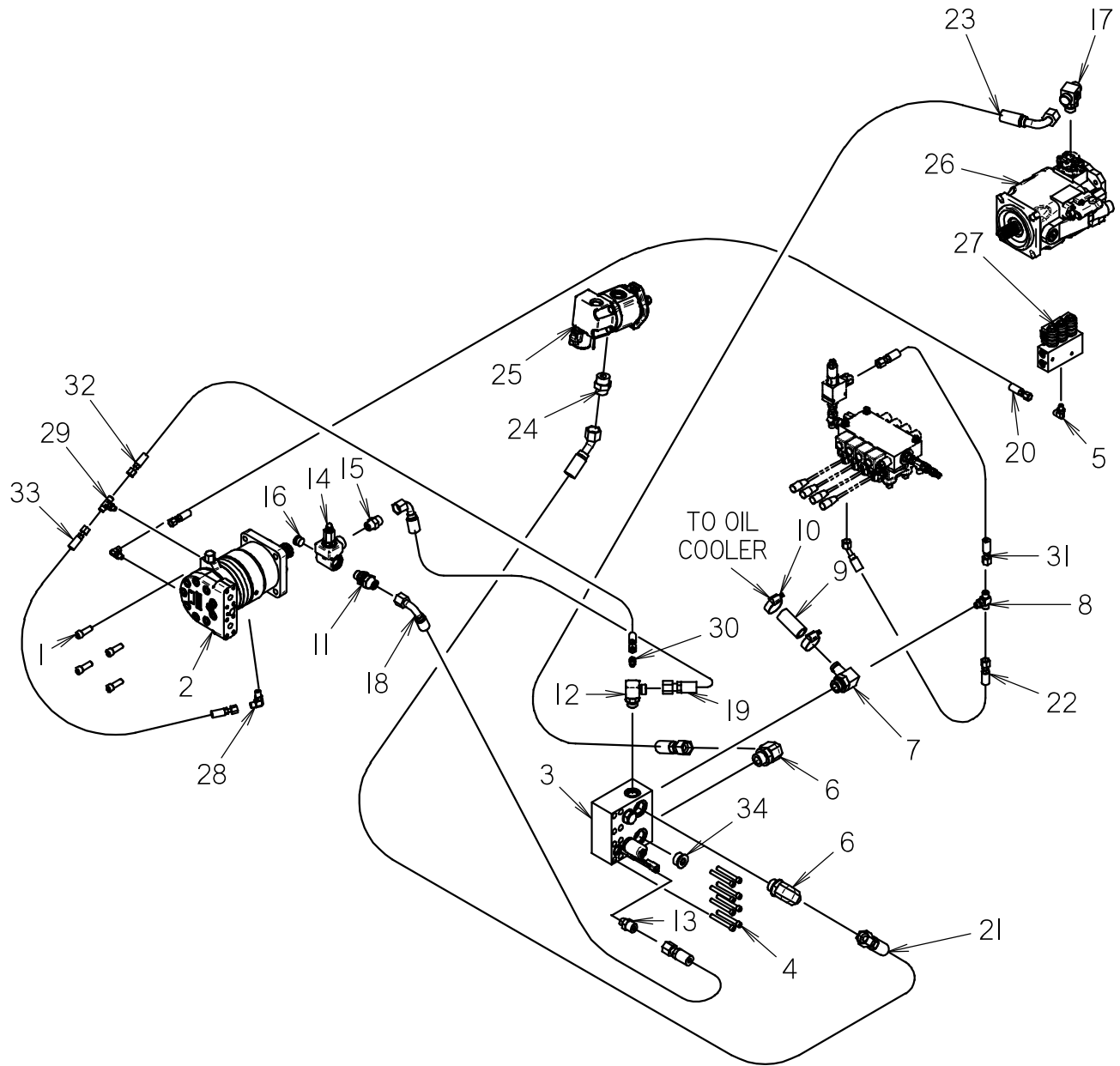

FLUID PUMP HYDRAULICS

ENDS WITH S/N: JT-CMW30M1C80000131, AT-CMWJ30ATC80000062

REF NO.	PART NUMBER	QTY	DESCRIPTION	REMARKS
1	I06-204	4	BOLT 1/2 - NC X 1.50", SOC)	USE 242 LOCTITE OR EQUIVALENT, TORQUE TO 130 FT-LBS
2	I52-I52	1	HYDRAULIC MOTOR	SEAL KIT I50-I042
3	I50-I434	1	MUD MANIFOLD	SEE FOOTNOTE 1 FOR SERVICE PARTS
4	I05-857	8	BOLT 1/8-NC X 3", SOC, GD8)	USE 242 LOCTITE OR EQUIVALENT, TORQUE TO 55 FT-LBS
5	I54-252	2	CONNECTOR (04S-04090)	
6	I54-286	2	CONNECTOR (I20-I6S90)	
7	I50-I184	1	CONNECTOR (I6S-I6H-06SF)	
8	I54-346	1	BRANCH TEE (06S-060-060)	
9	I16-460	80	BULK HOSE (1", SOLD PER FT)	1 @ 80"
10	III-011	2	WORM CLAMP (1" TO 1-3/4")	
11	I50-I726	1	BK CONNECTOR (I00-I0SBK)	
12	I50-I818	1	BRANCH TEE	
13	I54-391	1	CONNECTOR (08S-I00)	
14	I53-675	1	ADJ HYD RELIEF VALVE 3000 PSI	
15	I54-301	1	CONNECTOR (I0S-I00)	
16	I55-I79	1	PLUG (I0S, SOC)	
17	I50-I207	1	BRANCH TEE (I2S-I20-I20-04SF)	
18	515-721	1	HOSE (I00FX90M-22"-3000)	
19	I50-I729	1	HOSE (I00FX90S-24"-3000)	
20	515-I42	1	HOSE (040FX-I35"-3000)	
21	I50-I556	1	HOSE (I20FX45-45"-3000)	
22	I50-I563	1	HOSE (060FX45-I9"-3000)	
23	I50-I553	1	HOSE (I20FX90-I30"-4000)	
24	I54-367	1	CONNECTOR (I20-I6S)	
25	I50-I051	1	HYDRAULIC MOTOR	
26	I50-I489	1	PUMP, ELECTRIC CONTROL (63CC)	SEE FOOTNOTE 2 FOR SERVICE PARTS
27	I59-554	1	MANIFOLD (3-SPI)	SEE FOOTNOTE 3 FOR SERVICE PARTS
28	I54-226	1	CONNECTOR (040-06S90)	
29	I54-293	1	BRANCH TEE (04S-040-040)	
30	I54-278	1	CONNECTOR (04S-040)	
31	515-265	1	HOSE (060FX-I4"-3000)	
32	I54-825	1	HOSE (040FX-I2"-3000)	
33	515-065	1	HOSE (040FX90S-I4"-3000)	
34	I55-I84	1	PLUG (I6S)	

NOT SHOWN:

FOOTNOTES:

1. I50-I433 CARTRIDGE VALVE
215-I133 COIL (12V)
I50-I899 CHECK VALVE
2. 500-I423 CONTROL VALVE
500-I424 SHAFT SEAL RING
500-I425 RETAINING RING
3. 499-446 SOLENOID (3 WAY-2 POS VALVE)
214-491 COIL, 12V

NOTE:

FLUID PUMP HYDRAULICS

BEGINS WITH S/N: JT-CMWJ30M1T80000132, AT-CMWJ30ATV80000063

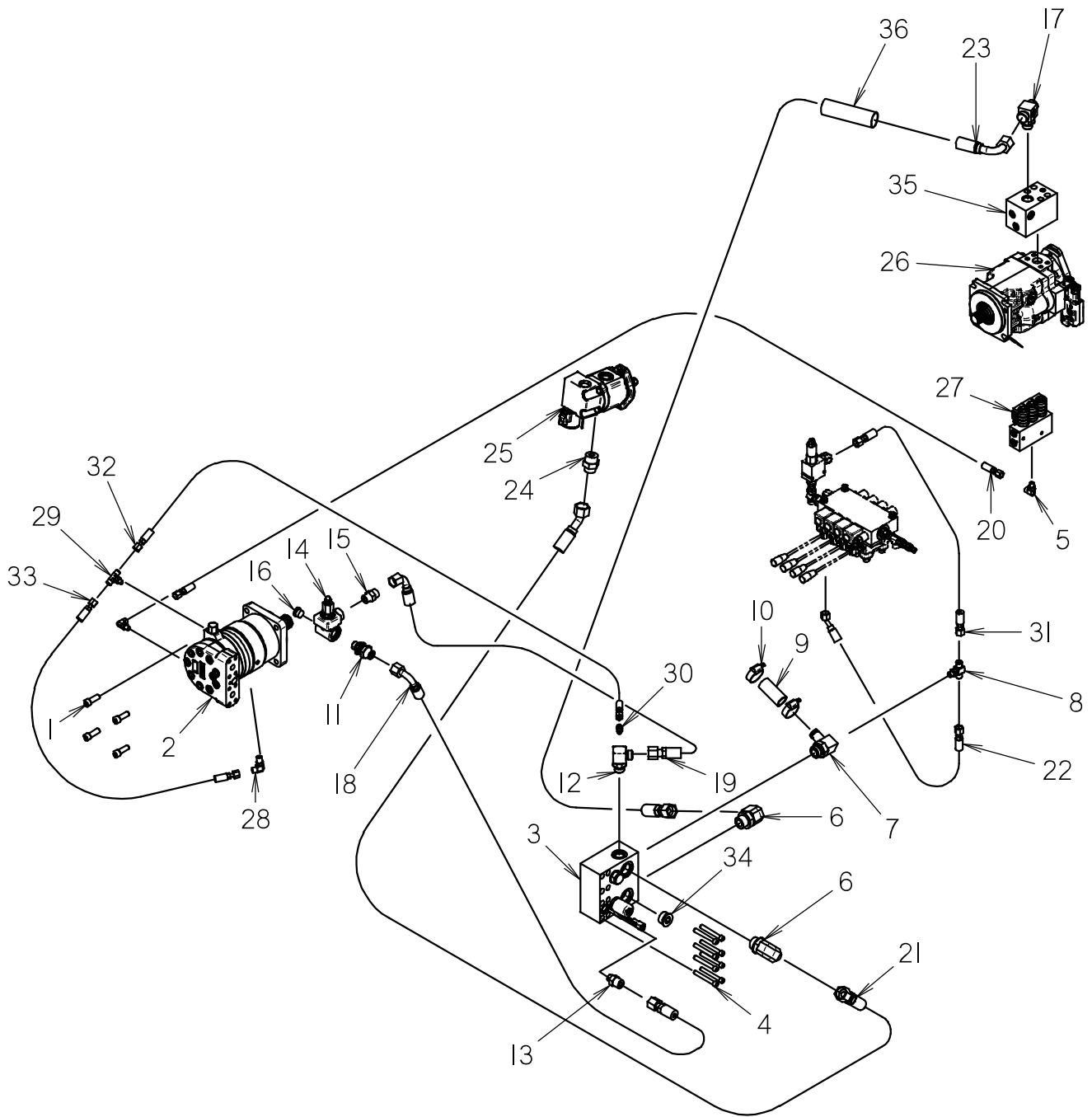

FLUID PUMP HYDRAULICS**BEGINS WITH S/N: JT-CMWJ30M1T80000132, AT-CMWJ30ATV80000063**

REF NO.	PART NUMBER	QTY	DESCRIPTION	REMARKS
1	I06-204	4	BOLT (1/2 - NC X 1.50", SOC)	USE 242 LOCTITE OR EQUIVALENT, TORQUE TO 130 FT-LBS
2	I52-I52	1	HYDRAULIC MOTOR	SEAL KIT I50-I042
3	I50-I434	1	MUD MANIFOLD	SEE FOOTNOTE I FOR SERVICE PARTS
4	I05-857	8	BOLT (3/8-NC X 3", SOC, GD8)	USE 242 LOCTITE OR EQUIVALENT, TORQUE TO 55 FT-LBS
5	I54-252	2	CONNECTOR (04S-04090)	
6	I54-286	2	CONNECTOR (I20-I6S90)	
7	I50-I184	1	CONNECTOR (I6S-I6H-06SF)	
8	I54-346	1	BRANCH TEE (06S-060-060)	
9	I16-460	80	BULK HOSE (1", SOLD PER FT)	I @ 80"
10	I11-011	2	WORM CLAMP (1" TO 1-3/4")	
11	I50-I726	1	BK CONNECTOR (I00-I0SBK)	
12	I50-I818	1	BRANCH TEE	
13	I54-391	1	CONNECTOR (08S-I00)	
14	I53-675	1	ADJ HYD RELIEF VALVE 3000 PSI	
15	I54-301	1	CONNECTOR (I0S-I00)	
16	I55-I79	1	PLUG (I0S, SOC)	
17	I50-I207	1	BRANCH TEE (I2S-I20-I20-04SF)	
18	515-721	1	HOSE (I00FX90M-22"-3000)	
19	I50-I729	1	HOSE (I00FX90S-24"-3000)	
20	515-I42	1	HOSE (040FX-I35"-3000)	
21	I50-I556	1	HOSE (I20FX45-45"-3000)	
22	I50-I563	1	HOSE (060FX45-I9"-3000)	
23	I50-2198	1	HOSE (I20FX90-I27"-4000)	
24	I54-367	1	CONNECTOR (I20-I6S)	
25	I50-I051	1	HYDRAULIC MOTOR	
26	I50-2113	1	LOAD SENSE PISTON PUMP, 60CC	
27	I59-554	1	MANIFOLD (3-SPI)	SEE FOOTNOTE I
28	I54-226	1	CONNECTOR (040-06S90)	
29	I54-293	1	BRANCH TEE (04S-040-040)	
30	I54-278	1	CONNECTOR (04S-040)	
31	515-265	1	HOSE (060FX-I4"-3000)	
32	I54-825	1	HOSE (040FX-I2"-3000)	
33	515-065	1	HOSE (040FX90S-I4"-3000)	
34	I55-I84	1	PLUG (I6S)	
35	I50-2137	1	PROPORTIONAL CARTRIDGE MANIFOLD	
36	I17-609	1	ABRASION SLEEVE (I.75" X I.25")	

NOT SHOWN:

FOOTNOTES:

I. USES COIL, 214-491, AS SERVICE PART AT QTY=3.

NOTE:

LUBRICATOR HYDRAULICS

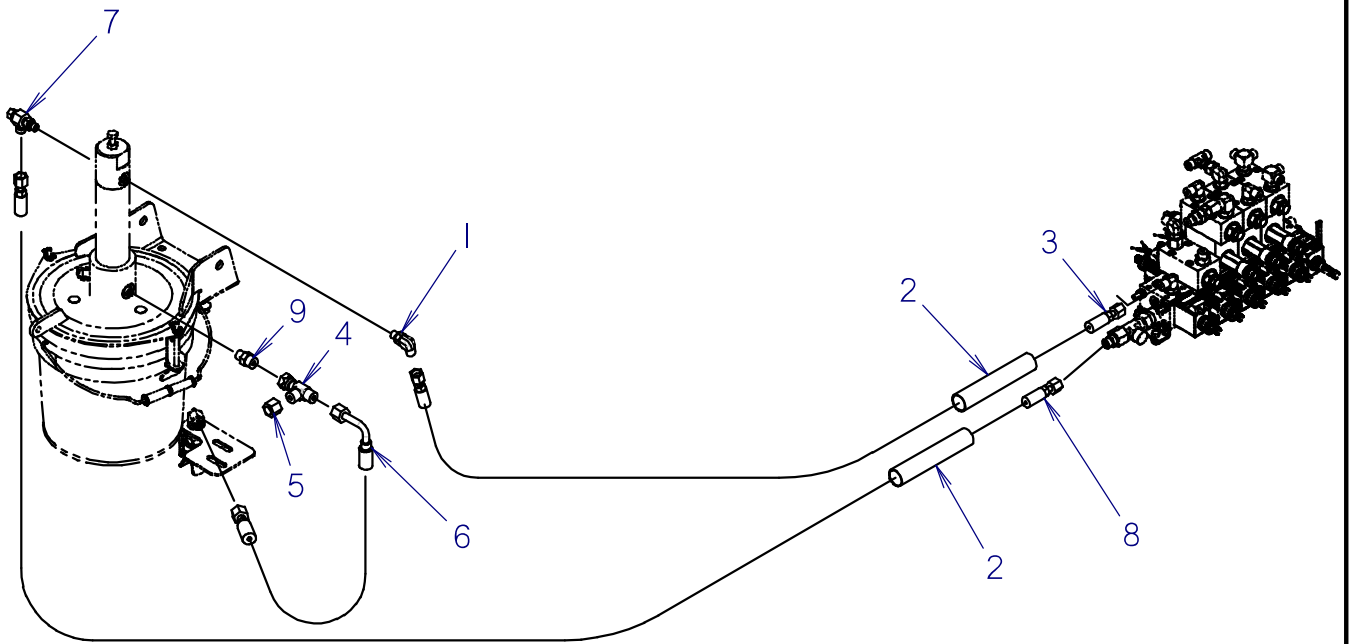

LUBRICATOR HYDRAULICS

REF NO.	PART NUMBER	QTY	DESCRIPTION	REMARKS
1	I54-252	1	CONNECTOR (O4S-04090)	
2	I17-399	2	ABRASION SLEEVE (1.00" X 130")	
3	515-142	1	HOSE (O40FX-I35"-3000)	
4	I54-344	1	UN RUN TEE (O60FX-060-060)	
5	I54-326	1	CAP (O60F)	
6	I49-825	1	HOSE (O60FX90L-28"-3000)	
7	I59-797	1	CONNECTOR (O4S-04090, ORF/CHK)	
8	515-142	1	HOSE (O40FX-I35"-3000)	
9	I54-221	1	CONNECTOR (O6S-060)	

NOT SHOWN:

FOOTNOTES:

NOTE:

HYDRAULIC CYLINDERS (2.0" X 1.0")

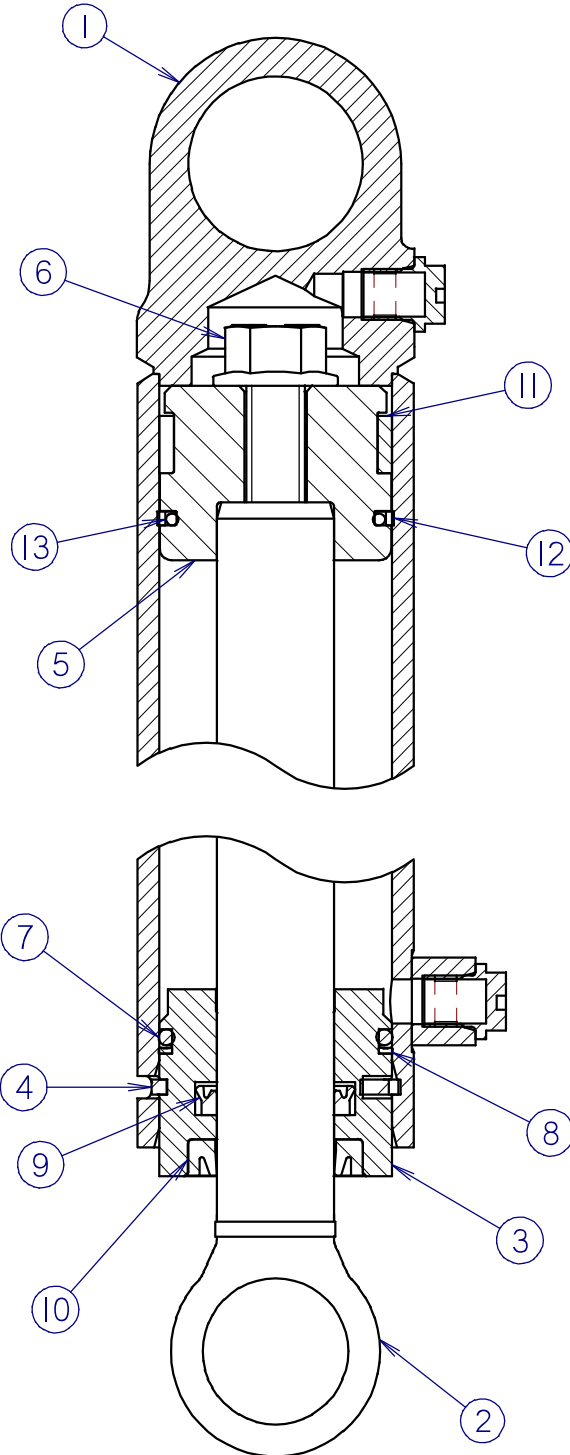

HYDRAULIC CYLINDERS (2.0" X 1.0")

REF NO.	PART NUMBER	QTY	DESCRIPTION	REMARKS
	151-094	-	CYL (2.0 X 1.0 X 2.0)	SEE FOOTNOTES 1 & 2
1	152-029	1	CYLINDER BARREL (2.0 X 2.0)	
2	153-007	1	CYLINDER ROD (1.00 X 2.0)	
	149-667	-	CYL (2.0 X 1.0 X 2.5)	SEE FOOTNOTES 1 & 2
1	149-761	1	CYLINDER BARREL (2.0 X 2.5)	
2	149-728	1	CYLINDER ROD (1.00 X 2.5)	
	151-027	-	CYL (2.0 X 1.0 X 3.0)	SEE FOOTNOTES 1 & 2
1	150-282	1	CYLINDER BARREL (2.0 X 3.0)	
2	150-414	1	CYLINDER ROD (1.00 X 3.0)	
	151-038	-	CYL (2.0 X 1.0 X 4.0)	SEE FOOTNOTES 1 & 2
1	150-290	1	CYLINDER BARREL (2.0 X 4.0)	
2	150-421	1	CYLINDER ROD (1.00 X 4.0)	
	151-039	-	CYL (2.0 X 1.0 X 5.0)	SEE FOOTNOTES 1 & 2
1	150-291	1	CYLINDER BARREL (2.0 X 5.0)	
2	150-422	1	CYLINDER ROD (1.00 X 5.0)	
	151-044	-	CYL (2.0 X 1.0 X 6.0)	SEE FOOTNOTES 1 & 2
1	150-294	1	CYLINDER BARREL (2.0 X 6.0)	
2	150-424	1	CYLINDER ROD (1.00 X 6.0)	
	151-031	-	CYL (2.0 X 1.0 X 8.0)	SEE FOOTNOTES 1 & 2
1	150-285	1	CYLINDER BARREL (2.0 X 8.0)	
2	150-417	1	CYLINDER ROD (1.00 X 8.0)	
	151-076	-	CYL (2.0 X 1.0 X 10.0)	SEE FOOTNOTES 1 & 2
1	152-017	1	CYLINDER BARREL (2.0 X 10.0)	
2	150-444	1	CYLINDER ROD (1.00 X 10.0)	
	149-668	-	CYL (2.0 X 1.0 X 12.0)	SEE FOOTNOTES 1 & 2
1	150-286	1	CYLINDER BARREL (2.0 X 12.0)	
2	149-729	1	CYLINDER ROD (1.00 X 12.0)	
3	150-772	1	CYLINDER HEAD (2.0 X 1.00)	
4	150-778	1	LOCK RING (2.0)	
5	150-775	1	CYLINDER PISTON (2.0 X 1.00)	
6	106-096	1	FLG BOLT (1/2-NC X 1-3/4",GD8)	SEE FOOTNOTE 3
7	157-022	1	O-RING (224 D90)	
8	155-732	1	BACKUP RING (224 D90)	
9	157-540	1	U-SEAL (1.000")	
10	157-537	1	WIPER SEAL (1.000")	
11	125-774	1	WEAR RING	
12	157-534	1	BACKUP RING (131 D90)	
13	157-018	1	O-RING (131 D90)	

NOT SHOWN:

259-100	U-SEAL INSTALLER (1" - 1.499")
259-235	1.00 ROD WIPER TOOL
259-239	WIPER/SEAL INSTALLER (2")
259-241	PISTON INSTALLER (2")
259-188	CYL HEAD SPANNER - TWO PIN

FOOTNOTES:

- REF. #1 & #2 ARE SPECIFIC TO EACH CYLINDER, REF. #3 THRU #13 ARE COMMON FOR ALL THE ABOVE LISTED CYLINDERS
- SEAL REPAIR KIT P/N: 190-165
- APPLY LOCTITE 277 OR EQUIVALENT, TORQUE TO 90-100 FT-LBS

NOTE:

HYDRAULIC CYLINDERS (2.0" X 1.25")

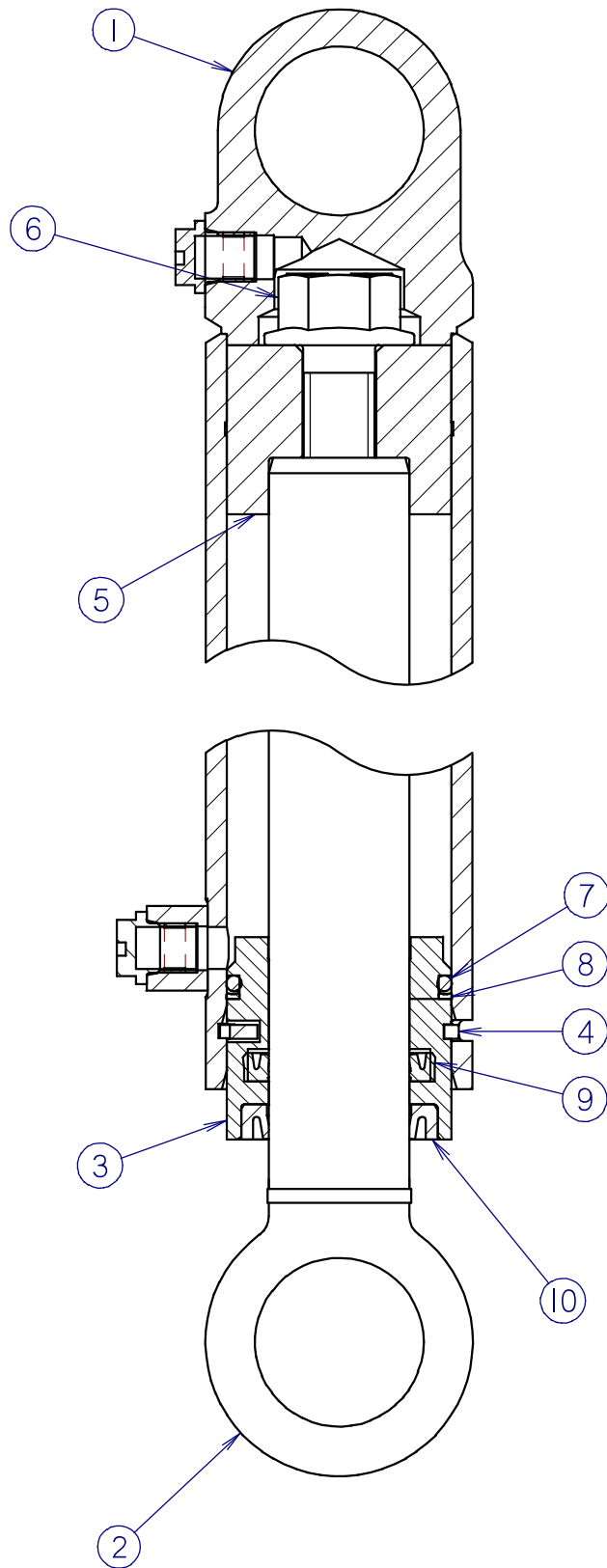

HYDRAULIC CYLINDERS (2.0" X 1.25")

REF NO.	PART NUMBER	QTY	DESCRIPTION	REMARKS
	149-669	-	CYL (2.0 X 1.25 X 2.0)	SEE FOOTNOTES 1 & 2
1	152-029	1	CYLINDER BARREL (2.0 X 2.0)	
2	153-012	1	CYLINDER ROD (1.25 X 2.0)	
	149-670	-	CYL (2.0 X 1.25 X 2.5)	SEE FOOTNOTES 1 & 2
1	149-761	1	CYLINDER BARREL (2.0 X 2.5)	
2	153-005	1	CYLINDER ROD (1.25 X 2.5)	
	149-671	-	CYL (2.0 X 1.25 X 3.0)	SEE FOOTNOTES 1 & 2
1	150-282	1	CYLINDER BARREL (2.0 X 3.0)	
2	150-435	1	CYLINDER ROD (1.25 X 3.0)	
	149-672	-	CYL (2.0 X 1.25 X 4.0)	SEE FOOTNOTES 1 & 2
1	150-290	1	CYLINDER BARREL (2.0 X 4.0)	
2	150-415	1	CYLINDER ROD (1.25 X 4.0)	
	151-060	-	CYL (2.0 X 1.25 X 5.0)	SEE FOOTNOTES 1 & 2
1	150-291	1	CYLINDER BARREL (2.0 X 5.0)	
2	150-423	1	CYLINDER ROD (1.25 X 5.0)	
	149-673	-	CYL (2.0 X 1.25 X 6.0)	SEE FOOTNOTES 1 & 2
1	150-294	1	CYLINDER BARREL (2.0 X 6.0)	
2	150-438	1	CYLINDER ROD (1.25 X 6.0)	
	151-057	-	CYL (2.0 X 1.25 X 8.0)	SEE FOOTNOTES 1 & 2
1	150-285	1	CYLINDER BARREL (2.0 X 8.0)	
2	150-427	1	CYLINDER ROD (1.25 X 8.0)	
	149-674	-	CYL (2.0 X 1.25 X 10.0)	SEE FOOTNOTES 1 & 2
1	152-017	1	CYLINDER BARREL (2.0 X 10.0)	
2	149-730	1	CYLINDER ROD (1.25 X 10.0)	
	151-032	-	CYL (2.0 X 1.25 X 12.0)	SEE FOOTNOTES 1 & 2
1	150-286	1	CYLINDER BARREL (2.0 X 12.0)	
2	150-418	1	CYLINDER ROD (1.25 X 12.0)	
	151-091	-	CYL (2.0 X 1.25 X 16.0)	SEE FOOTNOTES 1 & 2
1	152-027	1	CYLINDER BARREL (2.0 X 16.0)	
2	150-448	1	CYLINDER ROD (1.25 X 16.0)	
	151-065	-	CYL (2.0 X 1.25 X 20.0)	SEE FOOTNOTES 1 & 2
1	152-011	1	CYLINDER BARREL (2.0 X 20.0)	
2	150-439	1	CYLINDER ROD (1.25 X 20.0)	
3	150-770	1	CYLINDER HEAD (2.0 X 1.25)	
4	150-778	1	LOCK RING (2.0)	
5	150-771	1	CYLINDER PISTON (2.0 X 1.25)	INCL MOLDED-ON WEAR RING
6	106-097	1	FLG BOLT (5/8-NC X 1-3/4",GD8)	SEE FOOTNOTE 3
7	157-022	1	O-RING (224 D90)	
8	155-732	1	BACKUP RING (224 D90)	
9	157-541	1	U-SEAL (1.250")	
10	157-538	1	WIPER SEAL (1.250")	

NOT SHOWN:

259-100	U-SEAL INSTALLER (1" - 1.499")
259-236	WIPER INSTALLER (1.25")
259-239	WIPER/SEAL INSTALLER (2")
259-241	PISTON INSTALLER (2")
259-188	CYL HEAD SPANNER - TWO PIN

FOOTNOTES:

- REF. #1 & #2 ARE SPECIFIC TO EACH CYLINDER, REF. #3 THRU #10 ARE COMMON FOR ALL THE ABOVE LISTED CYLINDERS.
- SEAL KIT P/N 190-169
- APPLY LOCTITE 277 OR EQUIVALENT, TORQUE TO 180-200 FT-LBS

NOTE:

HYDRAULIC CYLINDERS (2.5" X 1.25")

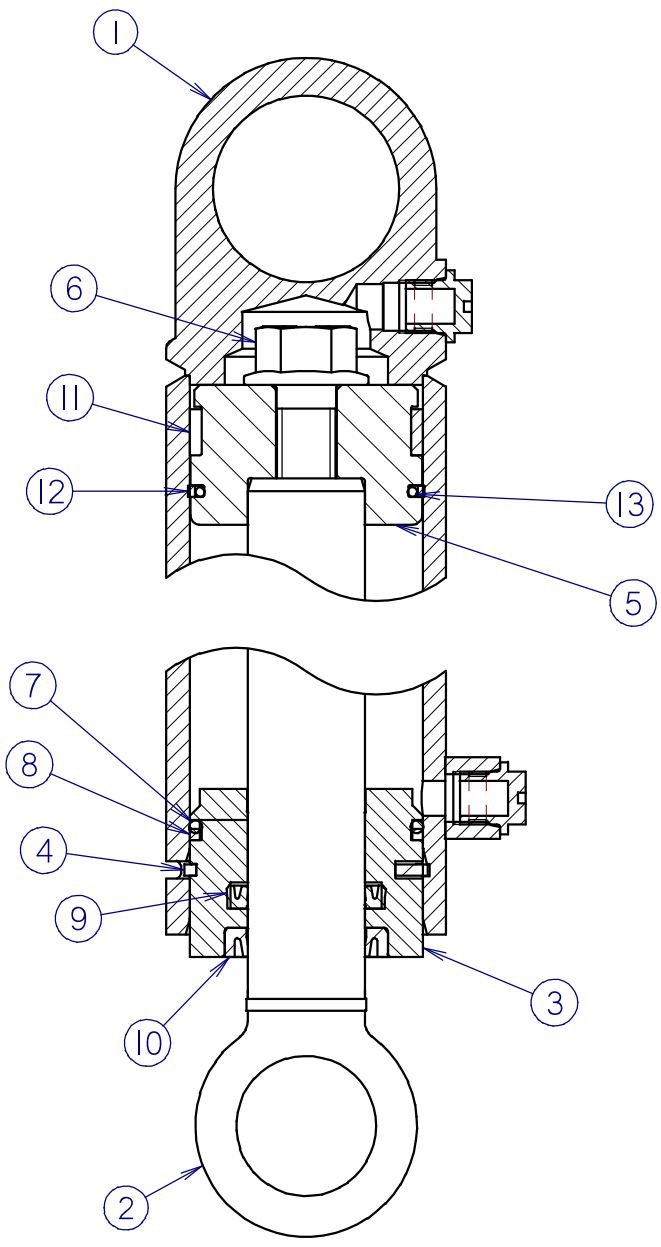

HYDRAULIC CYLINDERS (2.5" X 1.25")

REF NO.	PART NUMBER	QTY	DESCRIPTION	REMARKS
	151-101	-	CYL (2.5 X 1.25 X 2.0)	SEE FOOTNOTES 1 & 2
1	152-034	1	CYLINDER BARREL (2.5 X 2.0)	
2	153-012	1	CYLINDER ROD (1.25 X 2.0)	
	151-084	-	CYL (2.5 X 1.25 X 2.5)	SEE FOOTNOTES 1 & 2
1	152-022	1	CYLINDER BARREL (2.5 X 2.5)	
2	153-005	1	CYLINDER ROD (1.25 X 2.5)	
	151-055	-	CYL (2.5 X 1.25 X 3.0)	SEE FOOTNOTES 1 & 2
1	152-005	1	CYLINDER BARREL (2.5 X 3.0)	
2	150-435	1	CYLINDER ROD (1.25 X 3.0)	
	151-028	-	CYL (2.5 X 1.25 X 4.0)	SEE FOOTNOTES 1 & 2
1	150-283	1	CYLINDER BARREL (2.5 X 4.0)	
2	150-415	1	CYLINDER ROD (1.25 X 4.0)	
	149-797	-	CYL (2.5 X 1.25 X 5.0)	SEE FOOTNOTES 1 & 2
1	149-810	1	CYLINDER BARREL (2.5 X 5.0)	
2	150-423	1	CYLINDER ROD (1.25 X 5.0)	
	151-061	-	CYL (2.5 X 1.25 X 6.0)	SEE FOOTNOTES 1 & 2
1	152-010	1	CYLINDER BARREL (2.5 X 6.0)	
2	150-438	1	CYLINDER ROD (1.25 X 6.0)	
	151-045	-	CYL (2.5 X 1.25 X 8.0)	SEE FOOTNOTES 1 & 2
1	150-295	1	CYLINDER BARREL (2.5 X 8.0)	
2	150-427	1	CYLINDER ROD (1.25 X 8.0)	
	149-675	-	CYL (2.5 X 1.25 X 10.0)	SEE FOOTNOTES 1 & 2
1	150-692	1	CYLINDER BARREL (2.5 X 10.0)	
2	149-730	1	CYLINDER ROD (1.25 X 10.0)	
	151-180	-	CYL (2.5 X 1.25 X 12.0)	SEE FOOTNOTES 1 & 2
1	152-015	1	CYLINDER BARREL (2.5 X 12.0)	
2	150-418	1	CYLINDER ROD (1.25 X 12.0)	
3	150-773	1	CYLINDER HEAD (2.5 X 1.25)	
4	150-779	1	LOCK RING (2.5)	
5	150-776	1	CYLINDER PISTON (2.5 X 1.25)	
6	106-097	1	FLG BOLT (5/8-NC X 1-3/4",GD8)	SEE FOOTNOTE 3
7	500-031	1	O-RING (228 D90)	
8	157-021	1	BACKUP RING (228 D90)	
9	157-541	1	U-SEAL (1.250")	
10	157-538	1	WIPER SEAL (1.250")	
11	125-775	1	WEAR RING	
12	157-535	1	BACKUP RING (139 D90)	
13	157-019	1	O-RING (139 D90)	

NOT SHOWN:

259-100	U-SEAL INSTALLER (1" - 1.499")
259-236	WIPER INSTALLER (1.25")
259-242	PISTON SEAL INSTALLER (2.5")
259-243	PISTON INSTALLER (2.5")
259-188	CYL HEAD SPANNER - TWO PIN

FOOTNOTES:

- REF. #1 & #2 ARE SPECIFIC TO EACH CYLINDER, REF #3 THRU #13 ARE COMMON FOR ALL THE ABOVE LISTED CYLINDERS.
- SEAL REPAIR KIT P/N: 190-166
- APPLY LOCTITE 277 OR EQUIVALENT, TORQUE TO 180-200 FT-LBS

NOTE:

HYDRAULIC CYLINDERS (4.0" X 2.0")

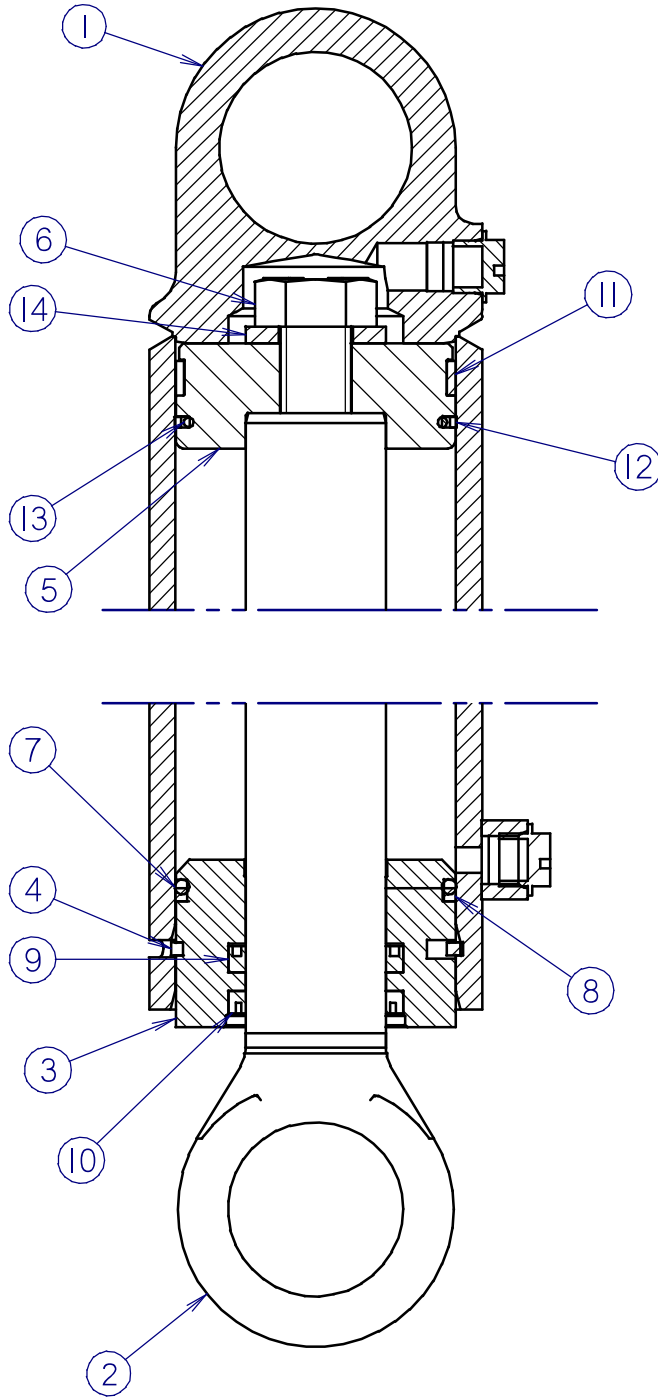

HYDRAULIC CYLINDERS (4.0" X 2.0")

REF NO.	PART NUMBER	QTY	DESCRIPTION	REMARKS
	149-698	-	CYL (4.0 X 2.0 X 4.0)	SEE FOOTNOTES 1 & 2
1	149-768	1	CYLINDER BARREL (4.0 X 4.0)	
2	153-021	1	CYLINDER ROD (2.00 X 4.0)	
	151-066	-	CYL (4.0 X 2.0 X 5.0)	SEE FOOTNOTES 1 & 2
1	152-012	1	CYLINDER BARREL (4.0 X 5.0)	
2	150-440	1	CYLINDER ROD (2.00 X 5.0)	
	149-699	-	CYL (4.0 X 2.0 X 6.0)	SEE FOOTNOTES 1 & 2
1	152-062	1	CYLINDER BARREL (4.0 X 6.0)	
2	149-735	1	CYLINDER ROD (2.00 X 6.0)	
	149-700	-	CYL (4.0 X 2.0 X 8.0)	SEE FOOTNOTES 1 & 2
1	152-030	1	CYLINDER BARREL (4.0 X 8.0)	
2	149-736	1	CYLINDER ROD (2.00 X 8.0)	
	149-701	-	CYL (4.0 X 2.0 X 10.0)	SEE FOOTNOTES 1 & 2
1	149-769	1	CYLINDER BARREL (4.0 X 10.0)	
2	153-016	1	CYLINDER ROD (2.00 X 10.0)	
	151-088	-	CYL (4.0 X 2.0 X 12.0)	SEE FOOTNOTES 1 & 2
1	150-298	1	CYLINDER BARREL (4.0 X 12.0)	
2	150-429	1	CYLINDER ROD (2.00 X 12.0)	
	149-702	-	CYL (4.0 X 2.0 X 16.0)	SEE FOOTNOTES 1 & 2
1	152-007	1	CYLINDER BARREL (4.0 X 16.0)	
2	149-737	1	CYLINDER ROD (2.00 X 16.0)	
	149-703	-	CYL (4.0 X 2.0 X 20.0)	SEE FOOTNOTES 1 & 2
1	149-770	1	CYLINDER BARREL (4.0 X 20.0)	
2	149-738	1	CYLINDER ROD (2.00 X 20.0)	
	149-704	-	CYL (4.0 X 2.0 X 24.0)	SEE FOOTNOTES 1 & 2
1	152-063	1	CYLINDER BARREL (4.0 X 24.0)	
2	149-739	1	CYLINDER ROD (2.00 X 24.0)	
3	149-006	1	CYLINDER HEAD (4.0 X 2.00)	
4	149-303	1	LOCK RING (4.0)	
5	149-307	1	CYLINDER PISTON (4.0 X 2.00)	
6	106-145	1	BOLT (1-NC X 2-1/4", GD8)	SEE FOOTNOTE 3
7	157-035	1	O-RING (342 D90)	
8	157-036	1	BACKUP RING (342 D90)	
9	157-559	1	U-SEAL (2.000")	
10	157-558	1	WIPER SEAL (2.000")	
11	125-793	1	WEAR RING	
12	157-570	1	BACKUP RING (238 D90)	
13	157-044	1	O-RING (238 D90)	
14	106-144	1	WASHER (1")	

FOOTNOTES

- REF. #1 & #2 ARE SPECIFIC TO EACH CYLINDER, REF. #3 THRU #14 ARE COMMON FOR ALL THE ABOVE LISTED CYLINDERS.
- SEAL REPAIR KIT P/N: 190-189
- APPLY LOCTITE 277 OR EQUIVALENT, TORQUE TO 630-700 FT-LBS

NOT SHOWN:

- 259-040 U-SEAL INSTALLER (1.5" - UP)
- 259-239 WIPER/SEAL INSTALLER (2")
- 259-246 PISTON SEAL INSTALLER (4")
- 259-247 PISTON INSTALLER (4")
- 259-188 CYL HEAD SPANNER - TWO PIN

A

809-369

HYDRAULIC CYLINDER (2.0 X 1.00 X 9.0)

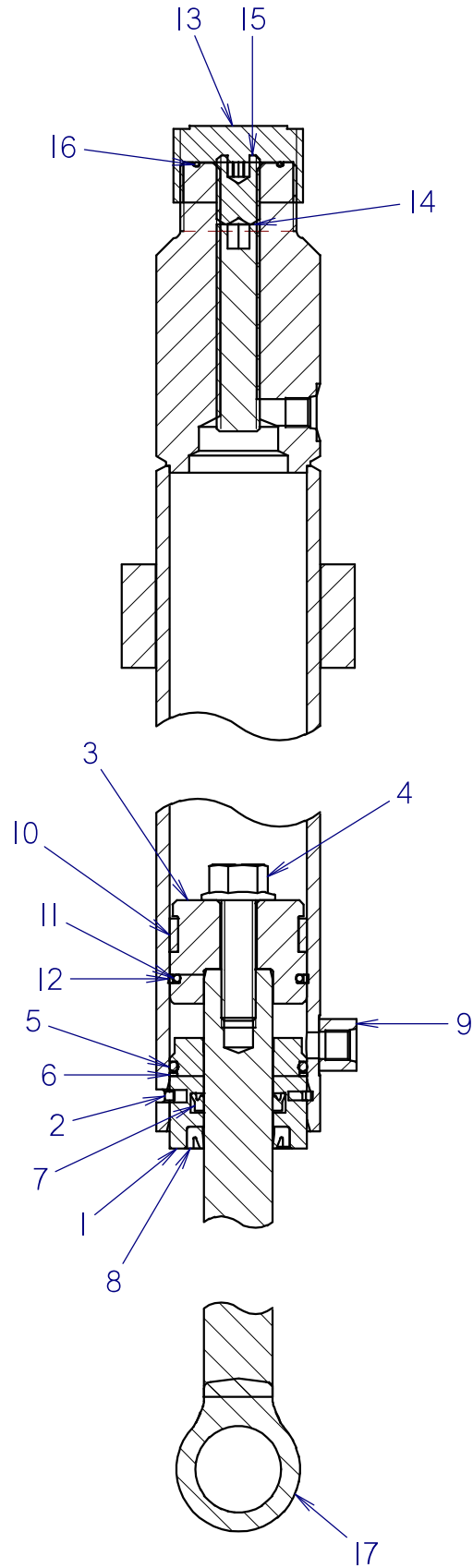

HYDRAULIC CYLINDER (2.0 X 1.00 X 9.0)

REF NO.	PART NUMBER	QTY	DESCRIPTION	REMARKS
	150-1398	-	CYL (2.0 X 1.00 X 8.0)	SEE FOOTNOTE 1
1	150-772	1	CYLINDER HEAD (2.0 X 1.00)	
2	150-778	1	LOCK RING (2.0)	
3	150-775	1	CYLINDER PISTON (2.0 X 1.00)	
4	106-096	1	FLG BOLT (1/2-NC X 1-3/4",GD8)	SEE FOOTNOTE 2
5	157-022	1	O-RING (224 D90)	
6	155-732	1	BACKUP RING (224 D90)	
7	157-540	1	U-SEAL (1.000")	
8	157-537	1	WIPER SEAL (1.000")	
9	300-2723	1	CYLINDER BARREL (2.0 X 9.0)	
10	125-774	1	WEAR RING	
11	157-018	1	O-RING (131 D90)	
12	157-534	1	BACKUP RING (131 D90)	
13	514-177	1	CAP (200F)	
14	105-1111	1	SET SCREW (5/8-11 UNC X 3.00")	
15	107-742	1	SET SCREW (5/8-NC X1",KNRL)	
16	157-129	1	O-RING (025 D90)	
17	150-1860	1	CYLINDER ROD (1.00 X 9.00)	

NOT SHOWN:

259-100	U-SEAL INSTALLER (1" - 1.499")
259-235	1.00 ROD WIPER TOOL
259-239	WIPER/PISTON SEAL INSTALLER (2")
259-241	PISTON INSTALLER (2")
259-188	CYL HEAD SPANNER - TWO PIN

FOOTNOTES:

1. SEAL REPAIR KIT (2" X 1") P/N: 190-165
2. ADD LOCTITE 277 OR EQUIVALENT, TORQUE TO 90-100 FT-LBS

NOTE:

HYDRAULIC CYLINDER (2.0 X 1.25 X 40.25)

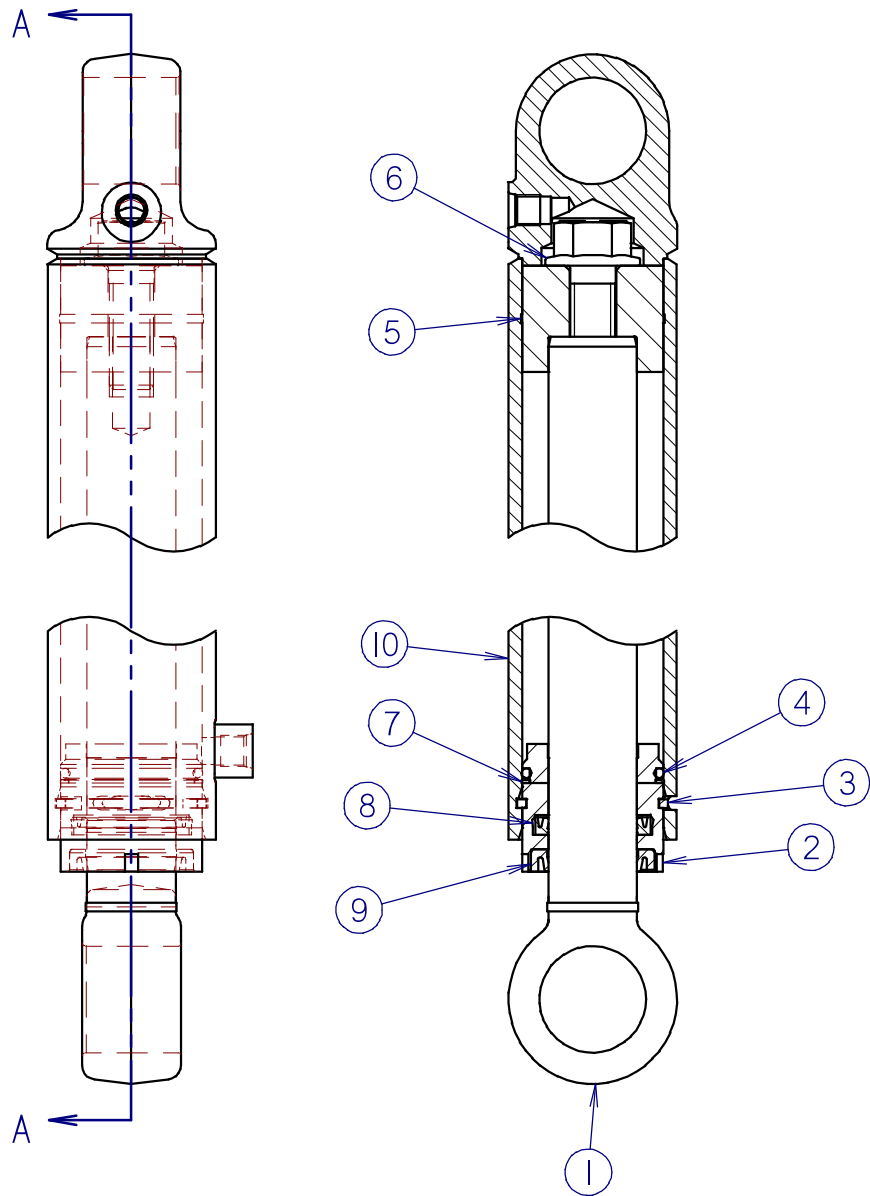

HYDRAULIC CYLINDER (2.0 X 1.25 X 40.25)

REF NO.	PART NUMBER	QTY	DESCRIPTION	REMARKS
	149-669	-	CYL (2.0 X 1.25 X 40.25)	SEE FOOTNOTE 1
1	150-1084	1	CYLINDER ROD (1.25 X 40.25)	
2	150-770	1	CYLINDER HEAD (2.0 X 1.25)	
3	150-778	1	LOCK RING (2.0)	
4	157-022	1	O-RING (224 D90)	
5	150-771	1	CYLINDER PISTON (2.0 X 1.25)	
6	106-097	1	FLG BOLT (5/8-NC X 1-3/4",GD8)	SEE FOOTNOTE 2
7	155-732	1	BACKUP RING (224 D90)	
8	157-541	1	U-SEAL (1.250")	
9	157-538	1	WIPER SEAL (1.250")	
10	150-1086	1	CYLINDER BARREL (2.0 X 40.25)	

NOT SHOWN:

259-100	U-SEAL INSTALLER (1"-1.499")
259-236	WIPER INSTALLER (1.250")
259-239	WIPER/SEAL INSTALLER (2")
259-241	PISTON INSTALLER (2")
259-188	CYL HEAD SPANNER - TWO PIN

FOOTNOTES:

1. SEAL REPAIR KIT (2.0" x 1.25") P/N 190-169
2. APPLY LOCTITE 277 OR EQUIVALENT, TORQUE TO 180-200 FT-LBS

NOTE:

ELECTRICAL

**SEE TECHNICAL SUPPLEMENT FOR FURTHER
ELECTRICAL INFORMATION**

ANCHOR SYSTEMS

ANCHORS

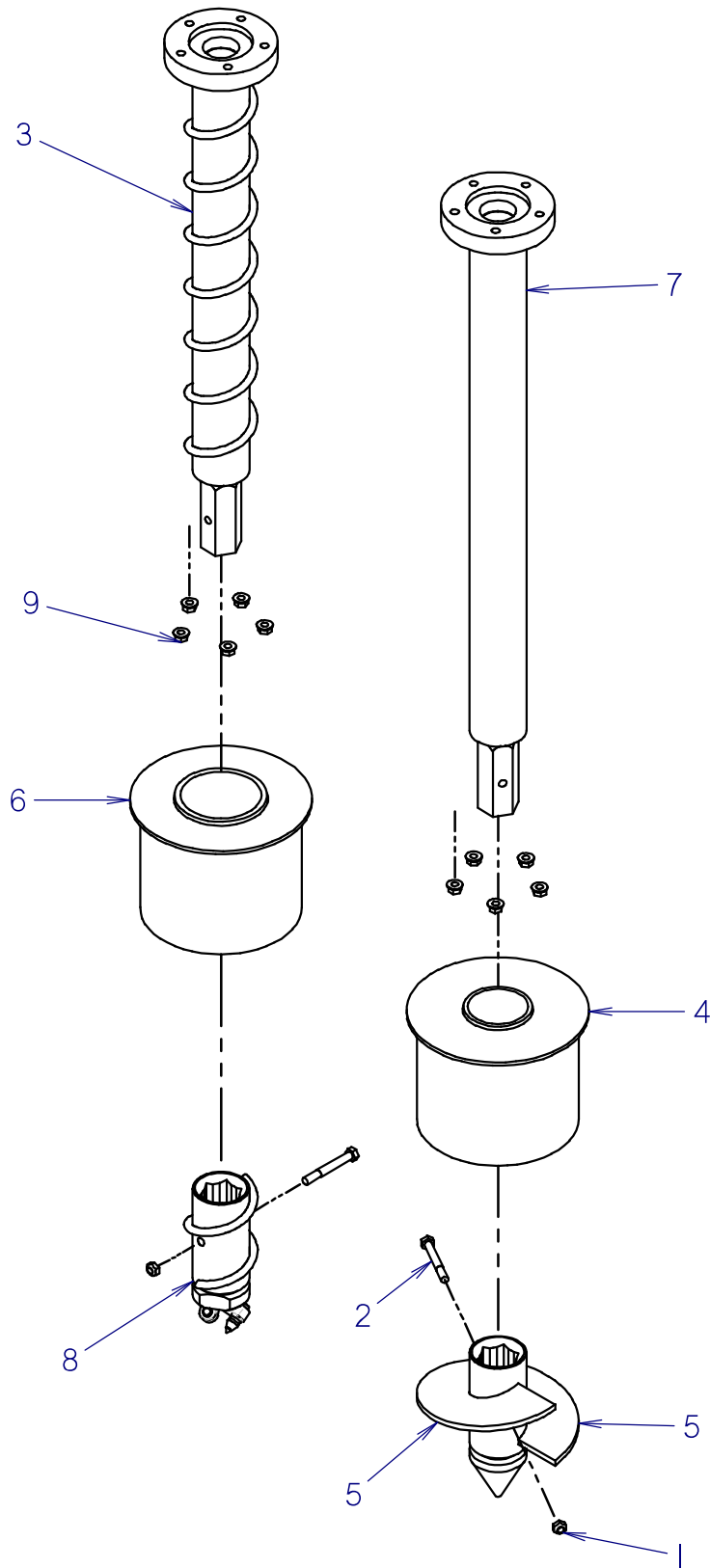

ANCHORS

REF NO.	PART NUMBER	QTY	DESCRIPTION	REMARKS
1	106-685	2	LOCKNUT(M12-1.75,PRV TRQ,10.9)	
2	106-584	2	SCREW (M12-1.75 X 100MM)	
3	300-3676	1	ANCHOR SHAFT	
4	329-506	1	CENTERING CAP	
5	300-3673	1	ANCHOR END, AUGER, 10"	
6	300-3693	1	CENTERING CAP	
7	300-3665	1	ANCHOR SHAFT	
8	300-4040	1	ROCK BIT ASSEMBLY	SEE FOOTNOTE 1
9	105-852	10	.5" LOCK NUT	

NOT SHOWN:

FOOTNOTES:

- I. INCLUDES 131-259 INSERT BIT (CARBIDE TIP) 4X

NOTE:

ANCHOR SYSTEM

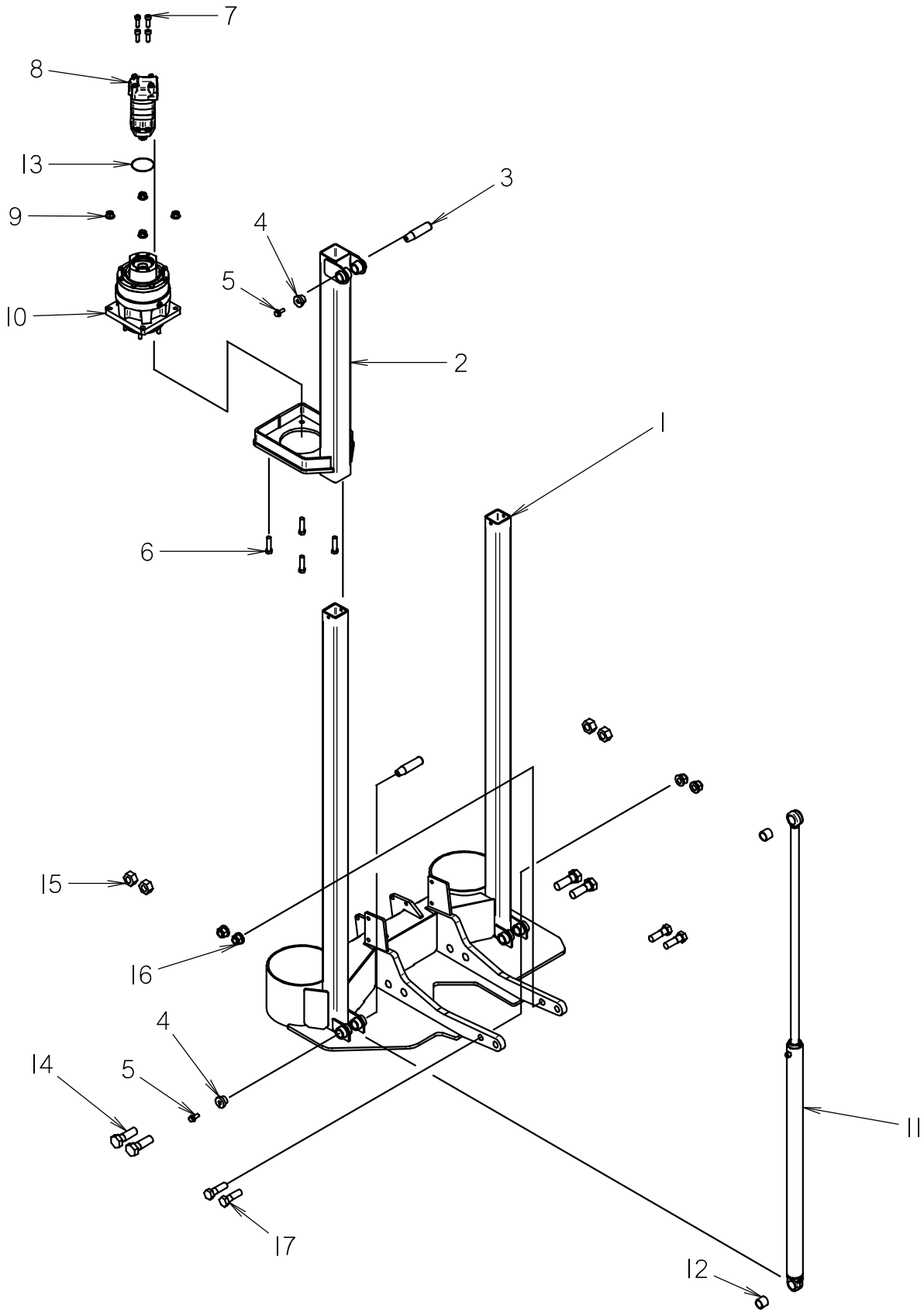

ANCHOR SYSTEM

REF NO.	PART NUMBER	QTY	DESCRIPTION	REMARKS
1	329-732	1	ANCHOR PLATE	
2	329-725	1	UPPER TUBE	
3	179-023	2	TAPERED PIN (31.7MM X 128MM)	
4	181-982	2	TAPERED INSERT (1.25")	
5	106-469	2	FLG SCREW (M12-1.75 X 30MM)	USE LOCTITE 242 OR EQUIVALENT
6	107-598	4	SCREW (M16 X 60MM, 10.9)	
7	106-204	4	BOLT (1/2 - NC X 1.50", SOC)	USE LOCTITE 242, TORQUE TO 130 FT-LBS
8	150-1243	1	HYD MOTOR	
9	106-442	4	FLG LKNUT (M16-2.0,PRVTRQ10.9)	
10	160-1035	1	GEARBOX	USE 1/2 QUART 90W
11	150-1083	1	CYL (2.0 X 1.25 X 40.25)	
12	125-771	2	COMPOSITION BUSHING (1.25")	
13	157-099	1	O-RING (042 D70)	
14	105-1074	4	SCREW (M30-3.5 X 90MM, 10.9)	USE LOCTITE 242 OR EQUIVALENT
15	105-1197	4	LOCKNUT (M30-3.50, 10.9)	
16	106-489	4	FLG NUT (M24-3.00, 10.9)	
17	107-152	4	SCREW (M24-3.00 X 80MM, 10.9)	USE LOCTITE 242 OR EQUIVALENT

NOT SHOWN:

329-723 - SHIM

FOOTNOTES:

NOTE:

ITEMS 2 THRU 13 QUANTITIES ARE 2X FOR ASSEMBLY OF OTHER SIDE

LUBRICATOR MOUNT

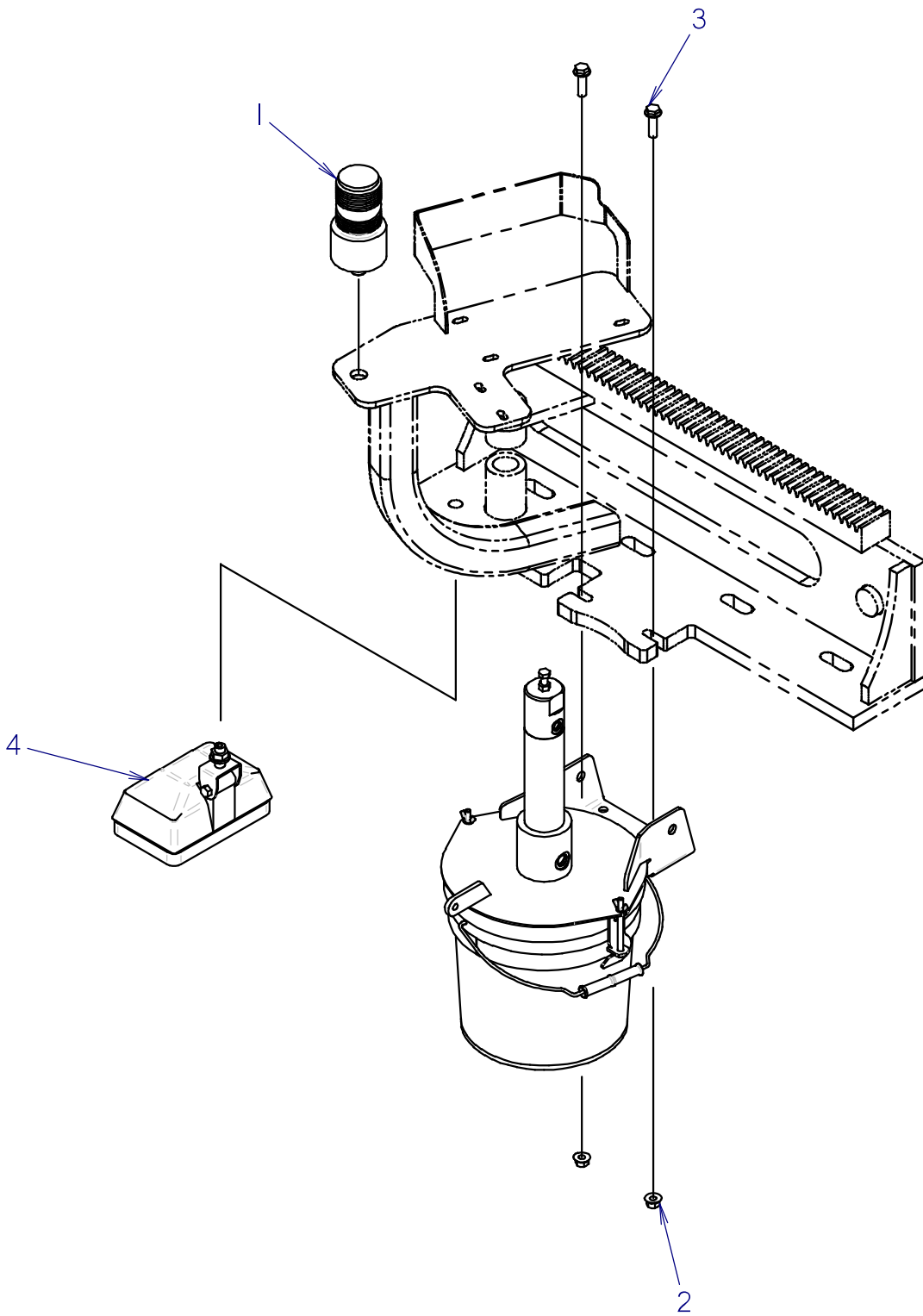

LUBRICATOR MOUNT

REF NO.	PART NUMBER	QTY	DESCRIPTION	REMARKS
1	217-297	1	STROBE LIGHT (GREEN)	SEE FOOTNOTE 1
2	106-387	2	FLG LOCKNUT (M10-1.50)	
3	106-497	2	FLG SCREW (M10-1.50 X 35MM)	
4	217-007	1	WORKING LIGHT (CLEAR, RECT)	SEE FOOTNOTE 1

NOT SHOWN:

FOOTNOTES:

I. INCLUDES THE FOLLOWING PARTS:

157-645	2	WEATHER-PAC (2.80MM)
214-103	1	(2-WAY) MALE CONNECTOR
214-104	2	PACKARD MALE TERMINAL

NOTE:

LUBRICATOR NOZZLE

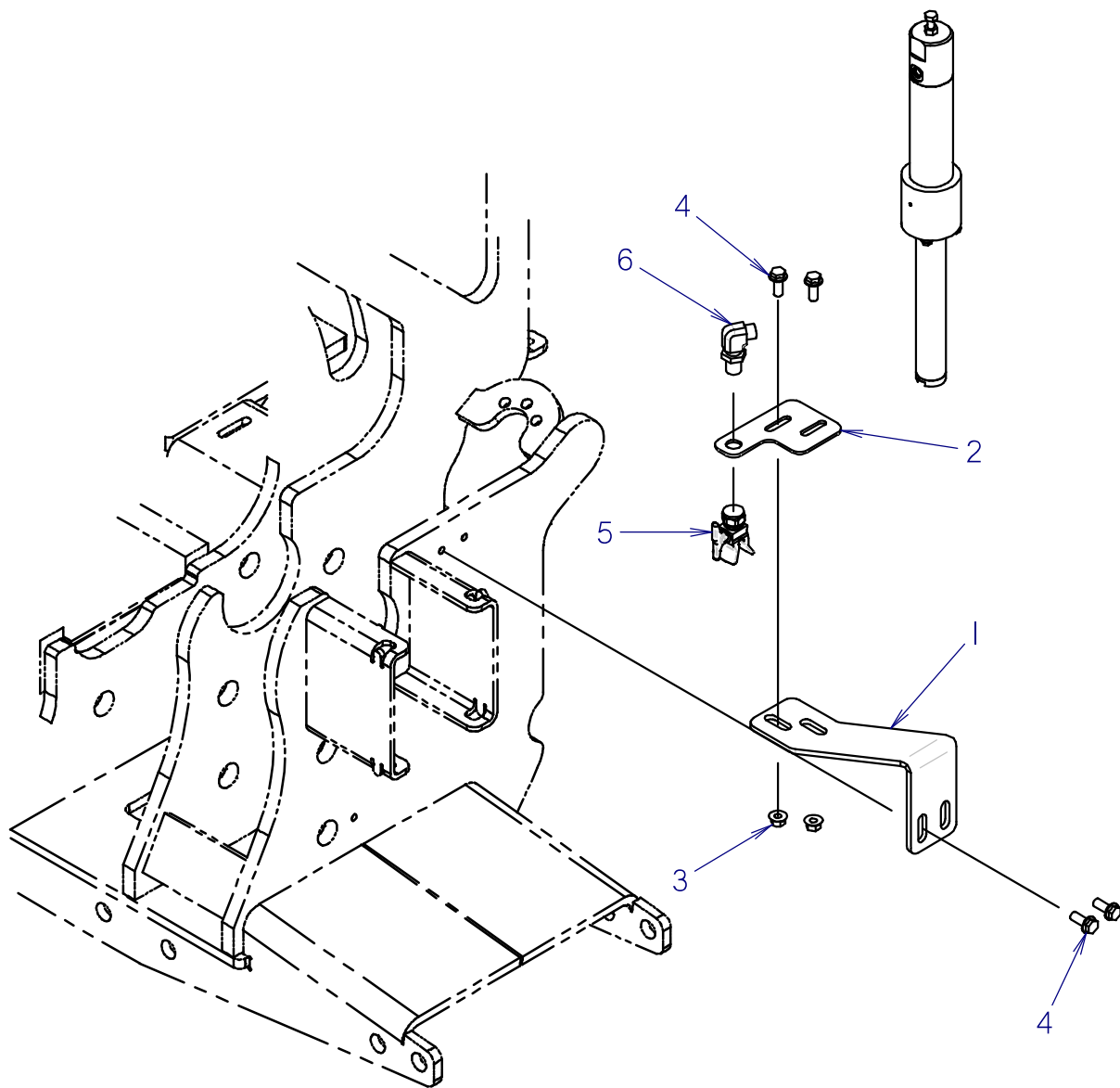

LUBRICATOR NOZZLE

REF NO.	PART NUMBER	QTY	DESCRIPTION	REMARKS
1	300-1062	1	BRACKET	
2	305-951	1	BRACKET, SPRAY	
3	106-387	2	FLG LOCKNUT (M10-1.50)	
4	107-001	4	FLG LK SCREW (M10-1.50 X 25MM)	
5	149-399	1	SPRAY NOZZLE (65)	
6	154-229	1	BK CONNECTOR (060-06090BK)	

NOT SHOWN:

FOOTNOTES:

NOTE:

AUTO-LUBER ASSEMBLY

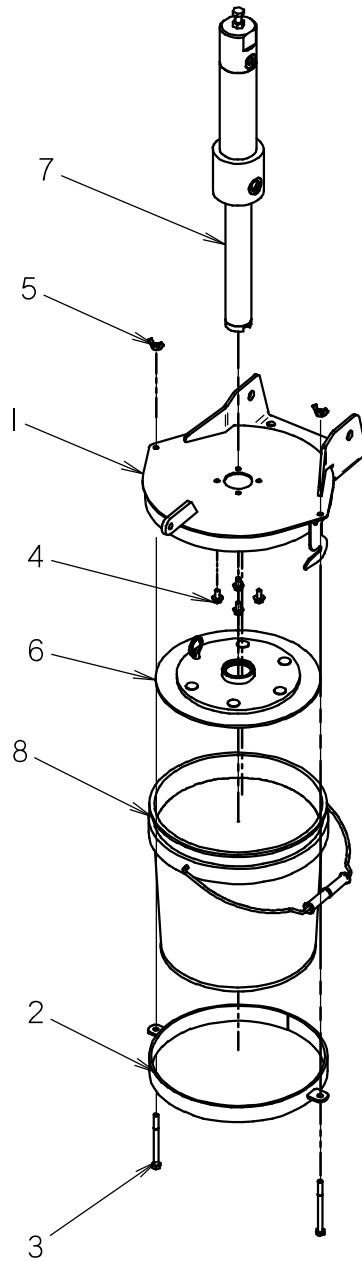

AUTO-LUBER ASSEMBLY

REF NO.	PART NUMBER	QTY	DESCRIPTION	REMARKS
1	350-400	1	COVER WELDMENT	
2	350-399	1	BASE	
3	105-297	2	BOLT (1/4-NC X 3-1/4")	
4	106-378	4	FLG LK SCREW (M6-1.00 X 12MM)	
5	195-339	2	WING NUT (1/4-NC)	
6	350-1932	1	TOOL JOINT LUBE FOLLOWER	
7	350-398	1	GREASE PUMP PARTS	
8	259-858	1	TOOL JNT LUBE, STD SPRY 2 GAL	
	256-031	-	TOOL JNT LUBE, SUMR SPRY 2 GAL	

NOT SHOWN:

FOOTNOTES:

NOTE:

FLUID SYSTEMS

FLUID PUMP ASSEMBLY

JT3020, JT3020AT, JT3020M1

ENDS WITH S/N _____

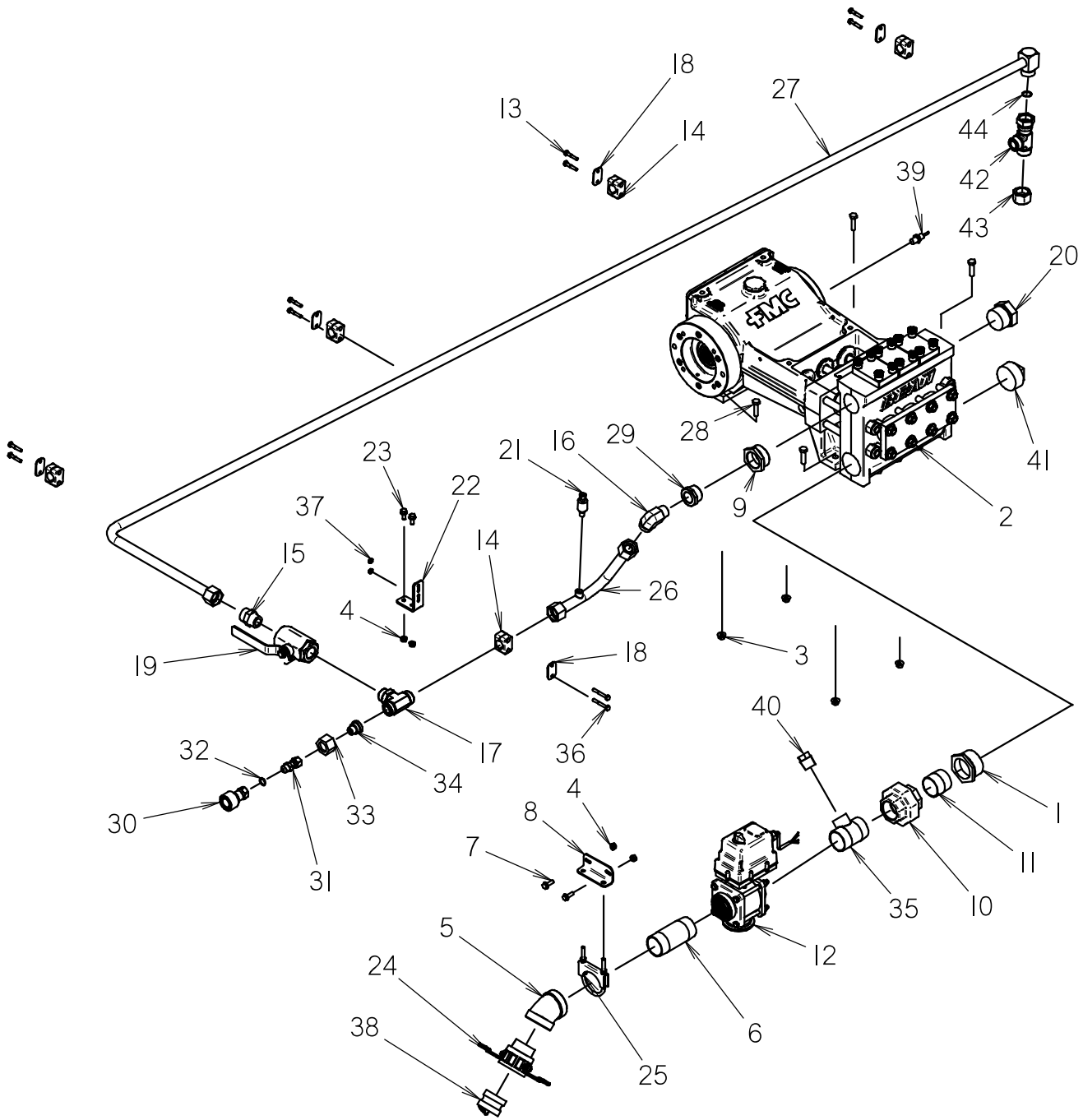

FLUID PUMP ASSEMBLY

JT3020, JT3020AT, JT3020M1
ENDS WITH S/N _____

REF NO.	PART NUMBER	QTY	DESCRIPTION	REMARKS
1	114-024	1	REDUCER (40N-32NF)	
2	158-274	1	FLUID PUMP	SEE FOOTNOTE 1
3	106-387	4	FLG LOCKNUT (M10-I.50)	
4	106-386	4	FLG LOCKNUT (M8-I.25)	
5	115-297	1	CONNECTOR (32NF-32NF45)	
6	114-014	1	NIPPLE (32N-5")	
7	106-381	2	FLG LK SCREW (M8-I.25 X 25MM)	
8	300-1123	1	CLAMP SUPPORT	
9	115-087	1	REDUCER (32N - 24NF)	
10	514-150	1	UNION (32NF-32NF)	
11	515-680	1	NIPPLE (32N-2")	
12	153-114	1	BALL VALVE, ELECTRIC, 2"	SEE FOOTNOTE 2
13	105-818	8	BOLT (1/4-NC X 1-1/2")	
14	110-573	5	BOLT-ON CLAMP (1";SOLD PER SET)	
15	154-281	1	CONNECTOR (16S-160)	
16	510-011	1	CONNECTOR (16N-16090)	
17	154-347	1	BRANCH TEE (16S-160-160)	
18	322-289	5	BACKUP (BOLT-ON)	
19	120-074	1	SHUT-OFF VALVE (16S-16S)	
20	156-938	1	PLUG (32N)	
21	215-1192	1	2000 PSI PRESSURE TRANSDUCER	SUPERCEDED BY TRANSDUCER KIT 190-1723
22	300-1509	1	BRACKET	
23	106-162	2	FLG SCREW (M8-I.25 X 20MM, GD8)	
24	159-485	1	FHC BODY (32-32N)	
25	196-354	1	MUFFLER CLAMP (2.5")	
26	150-1143	1	FLUID LINE	
27	150-1094	1	FLUID LINE	
28	105-271	4	SCREW (M10-I.50 X 40MM)	
29	115-261	1	REDUCER (24N-16NF)	
30	159-088	1	QDC BODY (08-08SF)	
31	156-732	1	CONNECTOR (08J-080)	
32	155-706	1	O-RING (908 D90)	
33	154-340	1	REDUCER NUT (160F)	
34	154-341	1	REDUCER STEM (080)	
35	150-1061	1	TEE (32N-32N-16N)	
36	105-106	2	BOLT (1/4-NC X 2")	
37	105-085	2	LOCKNUT (1/4"-NC)	
38	149-120	1	DUST PLUG	
39	216-047	1	SPEED PICK-UP	
40	115-110	1	PLUG (16N, SQ)	
41	156-944	1	PLUG (40N)	
42	154-409	1	UNION RUN TEE (160FX-160-160)	
43	154-329	1	CAP (160F)	
44	155-714	1	O-RING (021 D90)	

NOT SHOWN:

214-104 3 PACKARD MALE TERMINAL
157-645 3 WEATHER-PAC SEAL (2.80MM)
499-557 1 SIGHTGLASS

SEE FOOTNOTE 1

FOOTNOTES:

- SIGHT GLASS 499-557 IS A SERVICE PART FOR 158-274 PUMP.
- AFTER SERIAL NUMBERS CMWJ30M1AA0000338 AND CMWJ30ATHA0000204 USE SERVICE PARTS: MOTOR ASSEMBLY 500-1853, VALVE ASSEMBLY 500-1850 AND SEAL KIT 500-1852, 500-2064 (2) END PLATE NEW VERSION HAS "SD" STAMPED UNDERNEATH OF MOTOR AS PART OF DATE CODE. VALVES PRIOR TO THIS USE SERVICE PARTS: MOTOR ASSEMBLY 500-1714, VALVE ASSEMBLY 500-1715 AND SEAL KIT 500-1716.

NOTE:

* PIPE DOPE (LOCTITE 567)

FLUID PUMP (FLUID END)

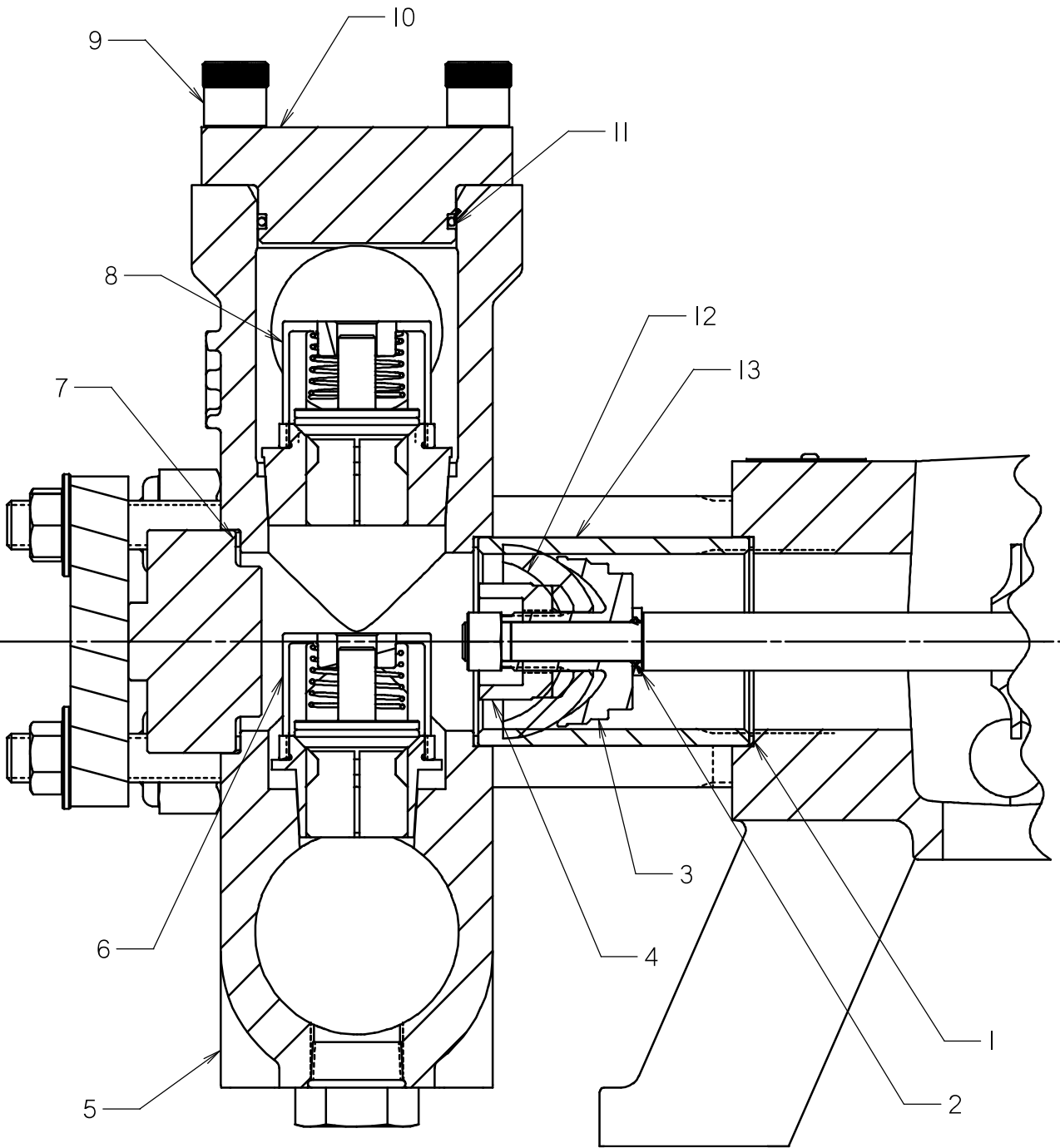

FLUID PUMP (FLUID END)

REF NO.	PART NUMBER	QTY	DESCRIPTION	REMARKS
	190-1206		VALVE SERVICE KIT	
	500-1717		PISTON SERVICE KIT	
1.	165-730	6	CYLINDER GASKET	
2.	499-116	1	O-RING (014 D70)	
3.	310-962	1	PISTON HOLDER	
4.	500-1348	1	PLUNGER NUT	
5.	500-1344	1	FLUID CYLINDER	
6.	499-036	1	VALVE	
7.	500-1347	1	GASKET	
8.	500-1345	3	VALVE ASSEMBLY	
9.	500-1351	12	ALLEN NUT	
10.	500-1350	3	VALVE COVER	
11.	500-1349	3	O-RING	
12.	500-1346	3	PISTON CUP	
13.	499-112	3	CERAMIC CYLINDER	

NOT SHOWN:

FOOTNOTES:

NOTE:

FLUID PUMP (POWER END)

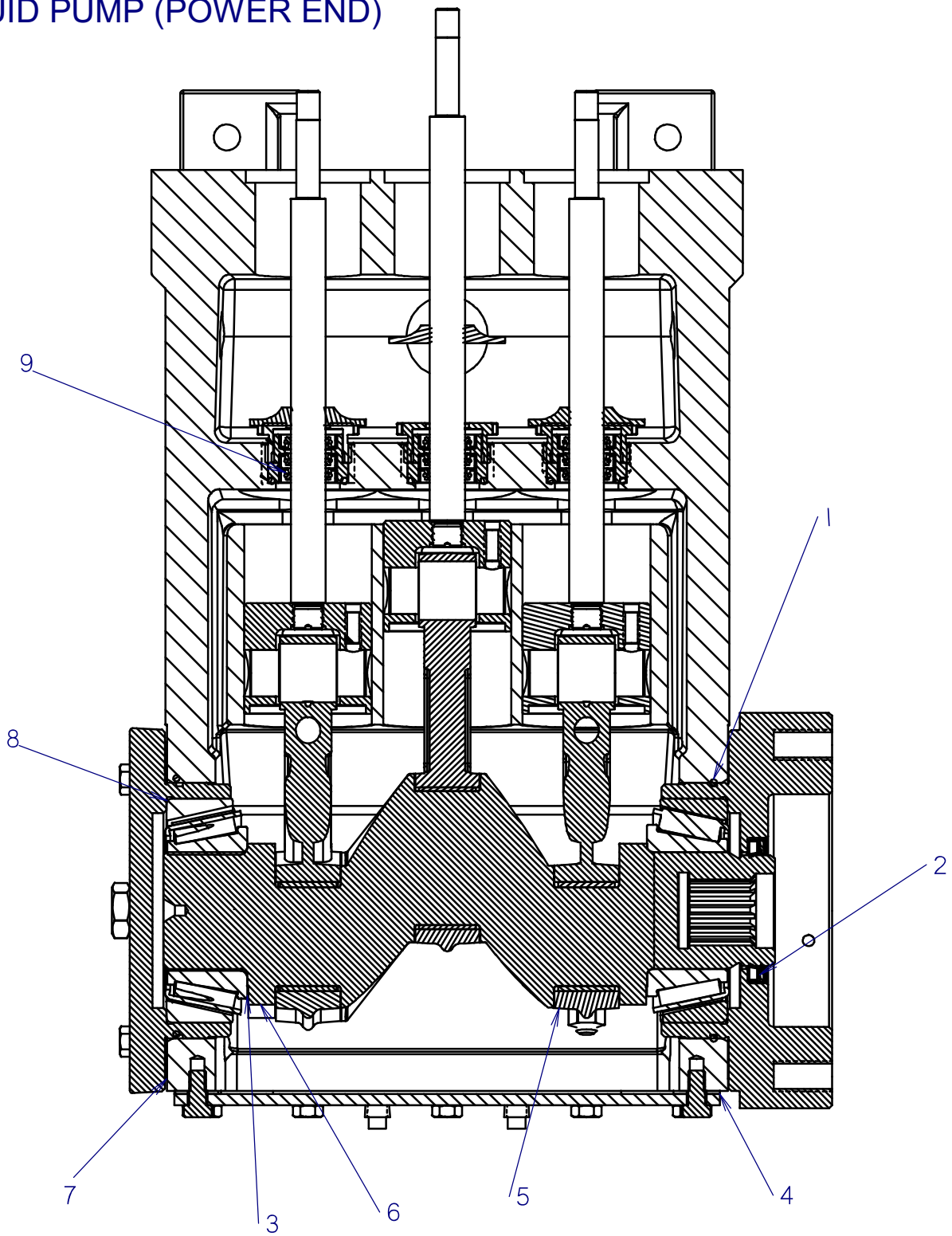

FLUID PUMP (POWER END)

REF NO.	PART NUMBER	QTY	DESCRIPTION	REMARKS
1.	500-1352	2	O-RING	
2.	500-1354	1	OIL SEAL	
3.	500-1355	2	BEARING CONE	
4.	165-747	1	REAR COVER GASKET	
5.	500-676	3	CONNECTING ROD	
6.	500-1359	1	CRANKSHAFT	
7.	500-1353	12	SHIM	
8.	500-1356	2	BEARING CUP	
9.	499-125	6	EXTERNAL SEAL (_____")	

NOT SHOWN:

FOOTNOTES:

NOTE:

PIPE LOADER SYSTEMS

PIPE LIFTERS

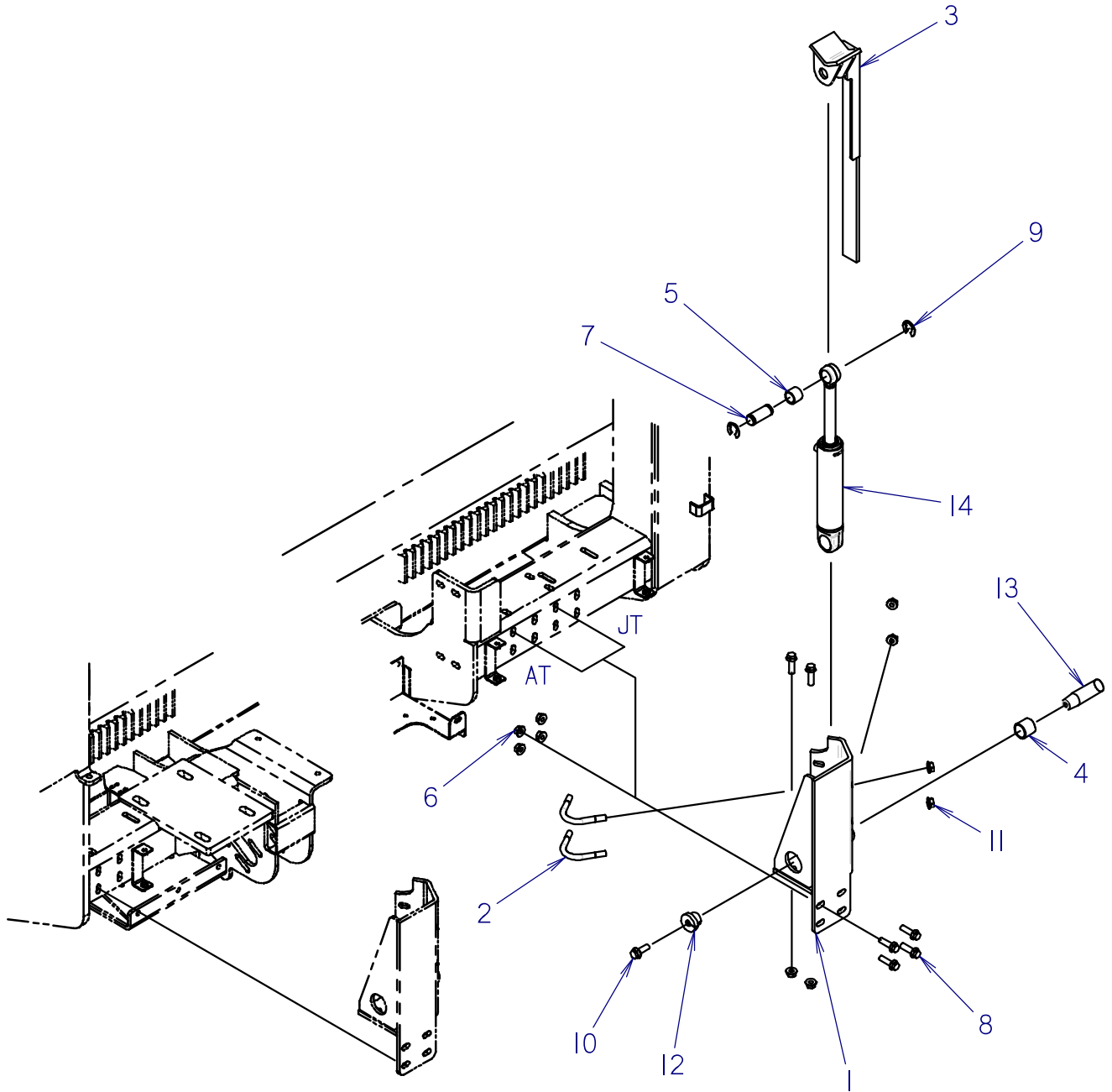

PIPE LIFTERS

REF NO.	PART NUMBER	QTY	DESCRIPTION	REMARKS
1	329-713	1	LIFT CYLINDER MOUNT	
2	108-242	2	U BOLT	
3	300-1002	1	PIPE LIFTER	
4	125-771	1	COMPOSITION BUSHING (1.25")	
5	125-770	1	COMPOSITION BUSHING (1.000")	
6	106-354	6	FLANGE NUT (M12-1.75)	
7	179-451	1	PIN	
8	107-565	6	FLG LK SCREW (M12-1.75 X 40MM)	
9	115-499	2	KLIP RING (1.000")	
10	106-632	1	FLG LK SCR (M12-1.75X35MM,SER)	
11	106-198	4	FLG LOCKNUT (1/2-NC, GD8)	
12	181-982	1	TAPERED INSERT (1.25")	
13	183-765	1	TAPERED PIN (31.7MM X 110MM)	
14	151-044	1	CYL (2.0 X 1.0 X 6.0)	

NOT SHOWN:

FOOTNOTES:

NOTE:

NOTE POSITION OF REAR LIFTER FOR JT AND AT APPLICATIONS

SHUTTLE

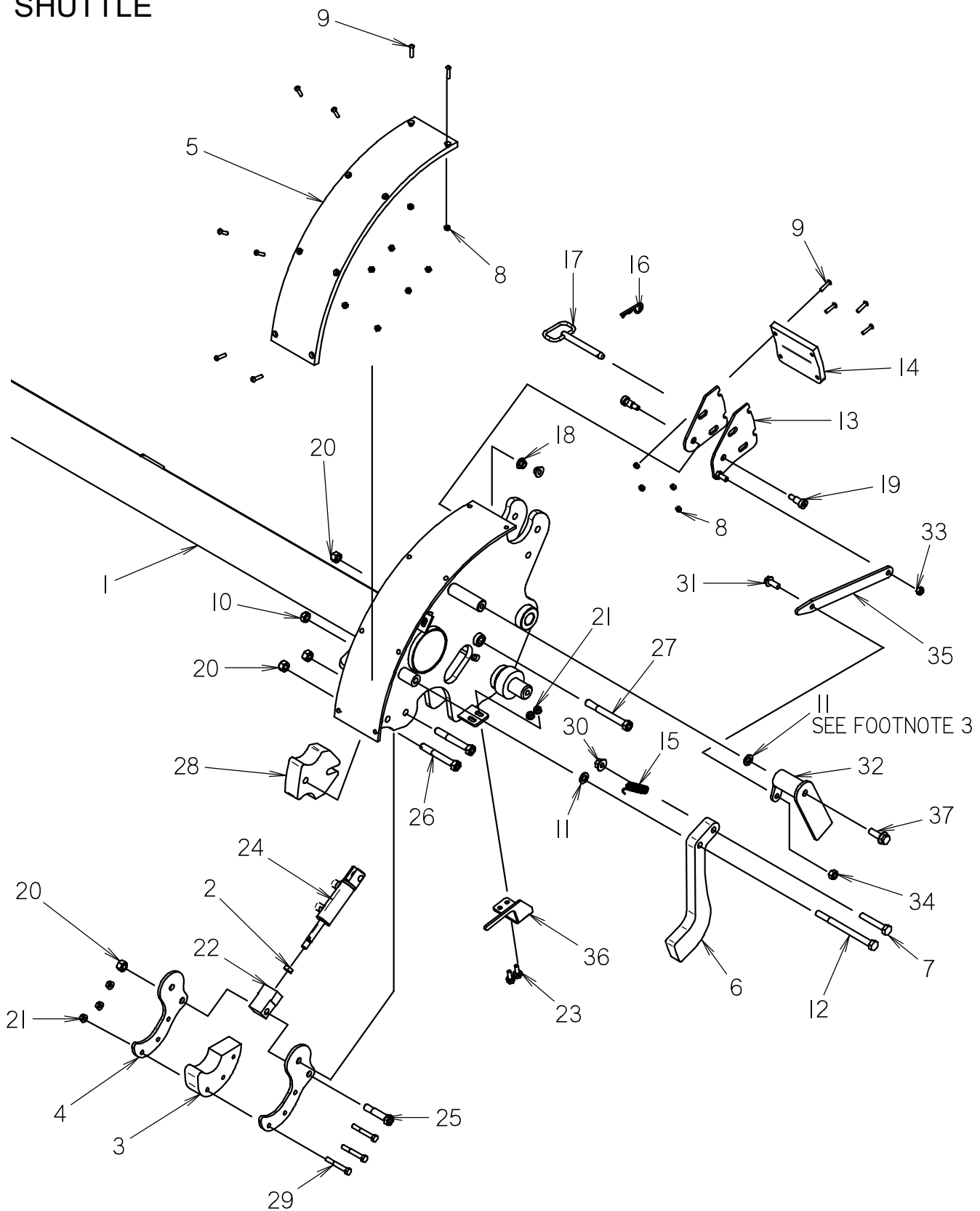

SHUTTLE

REF NO.	PART NUMBER	QTY	DESCRIPTION	REMARKS
1	329-783	1	SHUTTLE	FOR "JT" USE, SEE FOOTNOTE 4
2	105-920	1	JAM NUT (7/16-NF)	
3	118-492	1	GRIPPER PAD	FOR "JT" USE, SEE FOOTNOTE 1
4	329-669	2	GRIPPER PLATE	
5	118-491	1	SHUTTLE WEAR PAD	
6	300-4968	1	CATCH ARM	
7	106-720	1	SCREW (M12-1.75 X 70MM)	
8	106-237	12	LOCKNUT (M6-1.00,PRV TRQ,NLK)	
9	107-312	12	SCREW (M6-1.00 X 25MM, BUT SOCI)	
10	106-685	1	LOCKNUT(M12-1.75,PRV TRQ,10.9)	
11	106-391	2	WASHER (M12)	
12	107-213	1	SCREW (M12-1.75 X 160MM)	
13	300-5954	1	GATE	FOR USE ON FRONT; SEE FOOTNOTE 5
14	300-1695	1	FORMED PLATE	
15	115-601	1	EXTENSION SPRING (4.062)	
16	110-033	1	HAIR CLIP PIN (1/8" X 1/2")	
17	183-709	1	PULL PIN (500" X 3.500")	
18	105-814	2	FLG LOCKNUT (3/8-NC)	
19	107-646	2	SHLD BLT (1/2" X 3/4", 3/8-NC)	
20	105-065	4	LOCKNUT (1/2-NC)	
21	106-386	5	FLG LOCKNUT (M8-1.25)	
22	300-2774	1	ROD END	
23	106-162	2	FLG SCREW (M8-1.25 X 20MM, GD8)	
24	151-150	1	CYL (1.5" X .50" X 2")	
25	106-197	1	BOLT (1/2-NC X 2-1/2", GD8)	
26	105-549	2	BOLT (1/2-NC X 3-3/4", GD8)	
27	105-1116	1	SCREW (1/2-NC X 4-1/2", GD8)	
28	300-4075	1	GRIPPER PAD	FOR "JT" USE SEE FOOTNOTE 2
29	106-570	3	SCREW (M8-1.25 X 60MM)	
30	106-709	1	FLG LK NUT (M12-1.75)	
31	105-799	1	FLG LK SCREW (M10-1.50 X 25MM)	
32	300-5264	1	SENSOR ARM	FOR "JT" USE, SEE FOOTNOTE 6
33	105-047	1	LOCKNUT (3/8-NC)	
34	105-894	1	LOCKNUT(M10-1.50,PRV TRQ,10.9)	
35	300-5260	1	LINK	
36	300-5960	1	PROX FINGER	
37	107-003	1	FLG LK SCREW (M12-1.75 X 35MM)	

NOT SHOWN:

300-4083 AR SHIM
300-4084 AR SHIM

USE WITH 118-491
USE WITH 300-1695

FOOTNOTES:

- 118-1002 GRIPPER PAD; FOR "AT" USE
118-1004 GRIPPER PAD; FOR COBBLE USE
- 300-4078 GRIPPER PAD; FOR "AT" USE
300-4079 GRIPPER PAD; FOR COBBLE USE
- USE AS REQUIRED FOR PROPER DISTANCE FROM PROXIMITY SWITCH.
- 300-2592 "AT" SHUTTLE
- 300-4953 "REAR GATE"
- 300-5265 "AT" SENSOR ARM

NOTE:

PIPE BOX SHIFTER

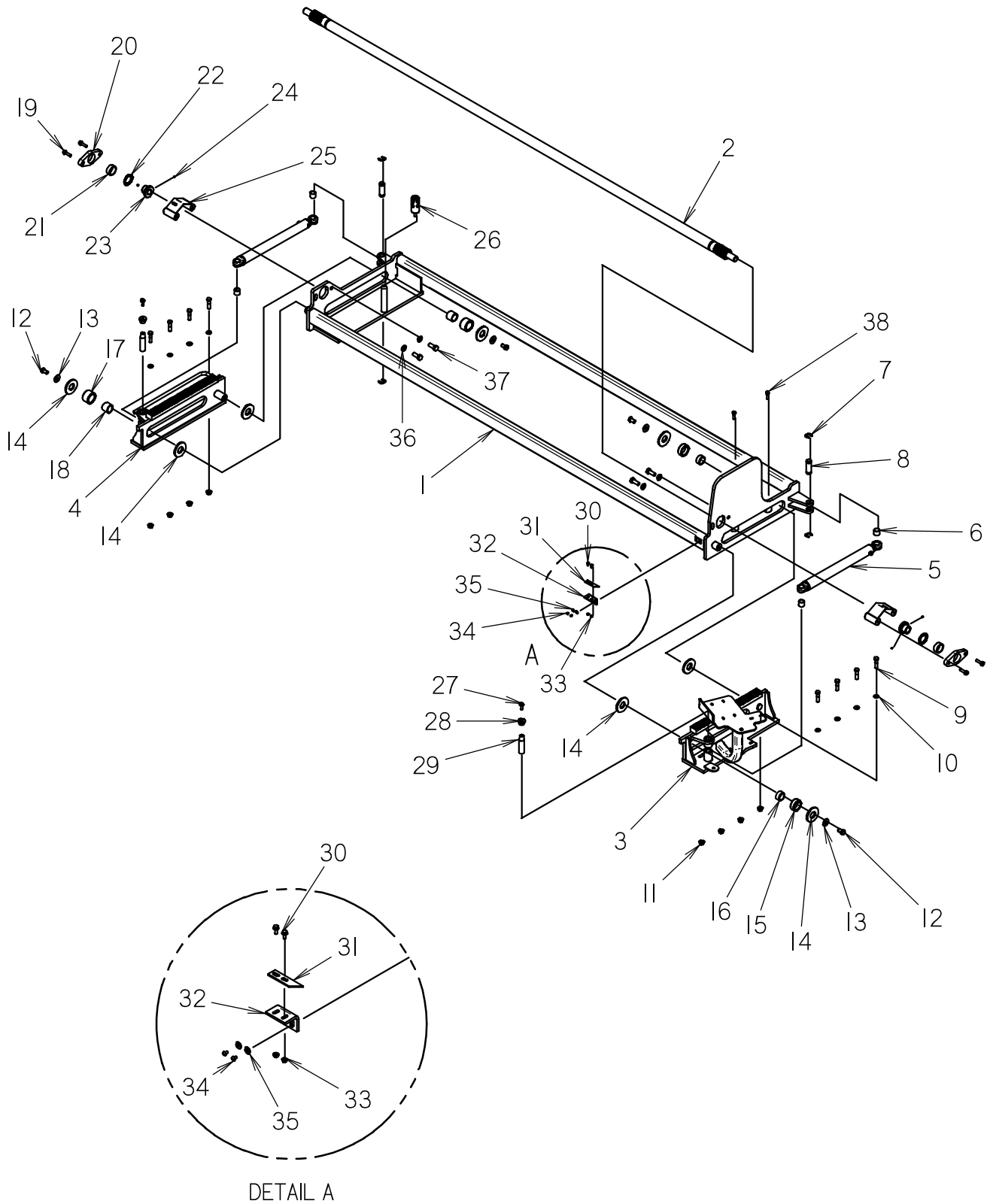

PIPE BOX SHIFTER

REF NO.	PART NUMBER	QTY	DESCRIPTION	REMARKS
1	300-2548	1	PIPE BOX CRADLE	
2	177-285	1	TORSION BAR	
3	301-2262	1	FRONT RACK	SEE FOOTNOTE 1
4	300-2558	1	BACK RACK	
5	151-065	2	CYL (2.0 X 1.25 X 20.0)	
6	125-771	4	COMPOSITION BUSHING (1.25")	
7	115-483	4	KLIP RING (1.250")	
8	183-223	2	CYLINDER EYE PIN	
9	106-666	8	SCREW (M16-2.00 X 65MM, 10.9)	USE LOCTITE 242 OR EQUIVALENT
10	106-398	8	WASHER (M16, HARDENED)	
11	106-355	8	FLG NUT (M16-2.00, 10.9)	
12	105-379	4	LK BOLT (3/4-NC X 1-1/4", NLK)	USE LOCTITE 242 OR EQUIVALENT
13	105-384	4	WASHER (3/4")	
14	177-288	8	RING	
15	177-287	2	ROLLER	
16	105-1086	2	COMPOSITION BUSHING	
17	300-1993	2	ROLLER	
18	125-773	2	COMPOSITION BUSHING (1.75")	
19	107-008	4	FLG LK SCREW (M12-1.75 X 50MM)	USE LOCTITE 242 OR EQUIVALENT
20	300-2553	2	BOSS	
21	125-521	2	COMPOSITION BUSHING (2.000")	
22	125-574	2	THRUST WASHER (2.00")	
23	300-2554	2	STOP COLLAR	
24	105-712	4	SET SCREW (1/4-NC X 1/4", CUPI)	USE LOCTITE 242 OR EQUIVALENT
25	300-1701	2	SPACER	
26	309-613	1	CAP LOCK	
27	106-632	2	FLG LK SCR (M12-1.75X35MM,SER)	USE LOCTITE 242 OR EQUIVALENT
28	181-982	2	TAPERED INSERT (1.25")	
29	179-053	2	TAPERED PIN (1.250" X 5.31")	
30	106-987	2	FLG LK SCREW (M6-1.00 X 16MM)	
31	300-2356	1	POINTER	
32	300-2355	1	BRACKET	
33	106-385	2	FLG LOCKNUT (M6-1.00)	
34	105-173	2	BOLT (1/4-NC X 3/8", SLT)	
35	105-095	2	WASHER (1/4")	
36	106-399	4	WASHER (M20, HARDENED)	
37	106-345	4	SCREW (M20-2.50 X 50MM)	USE LOCTITE 242 OR EQUIVALENT
38	106-477	2	SCREW (M12-1.75 X 45MM, 10.9)	

NOT SHOWN:

FOOTNOTES:

1. FRONT RACK 301-2262 BEGINS WITH S/N: _____. UNITS BEFORE THIS SERIAL NUMBER USE FRONT RACK 300-2555. FRONT RACK 301-2262 IS USED WITH ANCHOR VALVE 150-3304 AND FRONT RACK 300-2555 IS USED WITH ANCHOR VALVE 150-1197

NOTE:

SHUTTLE SUPPORTS

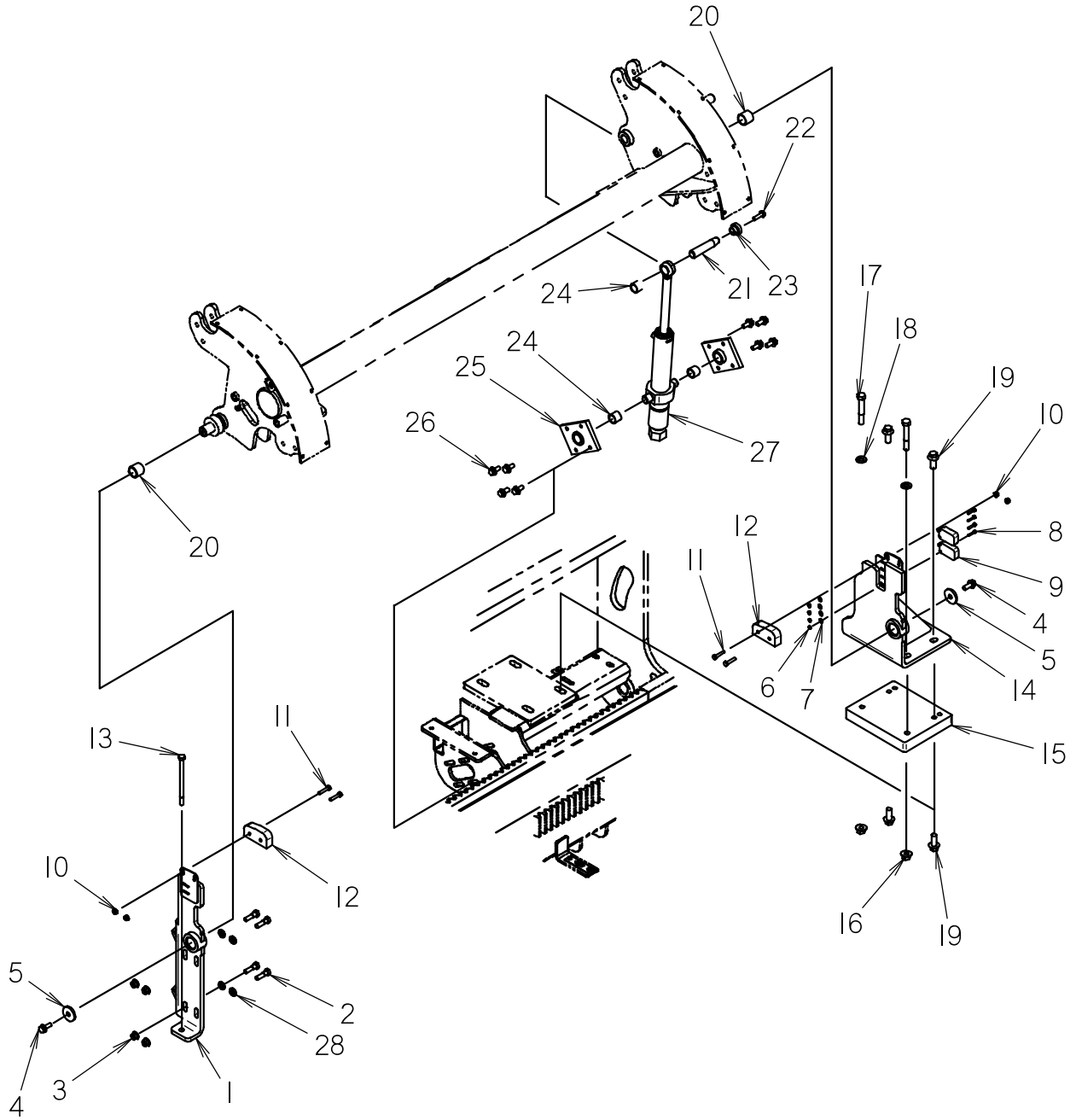

SHUTTLE SUPPORTS

REF NO.	PART NUMBER	QTY	DESCRIPTION	REMARKS
1	329-836	1	SHUTTLE SUPPORT	JT ONLY, SEE NOT SHOWN PARTS FOR AT
2	106-477	4	SCREW (M12-1.75 X 45MM, 10.9)	
3	106-354	4	FLANGE NUT (M12-1.75)	
4	106-469	2	FLG SCREW (M12-1.75 X 30MM)	
5	105-859	2	WASHER (.531")	
6	106-850	4	LOCKNUT (M5-0.80)	
7	105-284	4	WASHER (3/16")	
8	106-426	4	SCREW (M5-0.80 X 25MM, SOCI)	
9	215-1175	2	PROXIMITY SWITCH	
10	106-386	4	FLG LOCKNUT (M8-1.25)	
11	106-328	4	SCREW (M8-1.25 X 40MM)	
12	118-495	2	CATCH ARM WEAR PAD	
13	106-580	1	SCREW (M12-1.75 X 180MM)	
14	329-694	1	SHUTTLE SUPPORT	JT ONLY, SEE NOT SHOWN PARTS FOR AT
15	300-2907	1	MOUNT PLATE	
16	106-355	2	FLG NUT (M16-2.00, 10.9)	
17	107-144	2	SCREW (M16-2.00 X 100MM)	
18	106-398	2	WASHER (M16, HARDENED)	
19	106-470	4	FLG SCREW (M16-2.0 X 40MM)	
20	125-771	2	COMPOSITION BUSHING (1.25")	
21	179-024	1	TAPERED PIN (1.000" X 4.606")	
22	106-993	1	FLG LK SCREW (M10-1.50 X 35MM)	
23	181-981	1	TAPERED INSERT (1")	
24	125-770	3	COMPOSITION BUSHING (1.000")	
25	300-2284	2	BOSS	
26	106-806	8	FLG LK SCREW (M12-1.75 X 25MM)	
27	150-1398	1	CYL (2.0 X 1.00 X 9.0)	
28	106-397	4	WASHER (M12, HARDENED)	

NOT SHOWN:

300-2587	1	SHUTTLE SUPPORT	AT ONLY, REF #1
300-2950	1	SHUTTLE SUPPORT	AT ONLY, REF #14

FOOTNOTES:
NOTE:

PIPELOADER COVERS

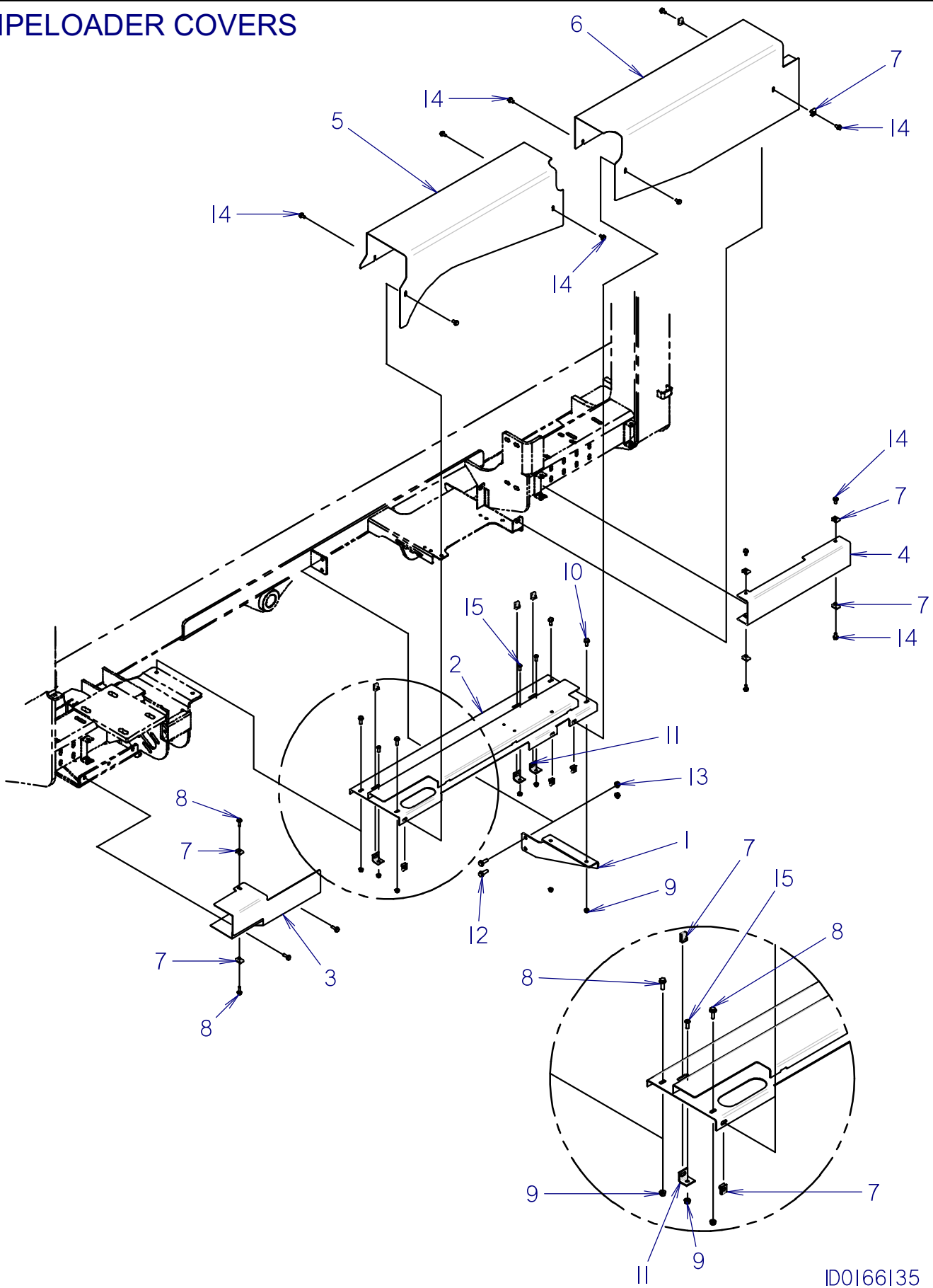

PIPELOADER COVERS

REF NO.	PART NUMBER	QTY	DESCRIPTION	REMARKS
1	300-1325	1	RIGHT TRAY MOUNT	
2	300-3156	1	TRAY	
3	300-2914	1	COVER	
4	300-1874	1	SIDE COVER	
5	300-1307	1	FRONT COVER	
6	300-1335	1	REAR COVER	
7	106-551	14	CLIP NUT (M8-1.25)	
8	106-381	6	FLG LK SCREW (M8-1.25 X 25MM)	
9	106-386	7	FLG LOCKNUT (M8-1.25)	
10	106-162	2	FLG SCREW (M8-1.25 X 20MM, GD8)	
11	320-656	3	CLIP NUT TAB	
12	106-383	2	FLG LK SCREW (M10-1.50 X 30MM)	
13	106-387	2	FLG LOCKNUT (M10-1.50)	
14	106-380	12	FLG LK SCREW (M8-1.25 X 16MM)	
15	107-032	3	BOLT (M8-1.25 X 20MM,BUT SOC)	

NOT SHOWN:

FOOTNOTES:

NOTE:

PIPELOADER CHUTES

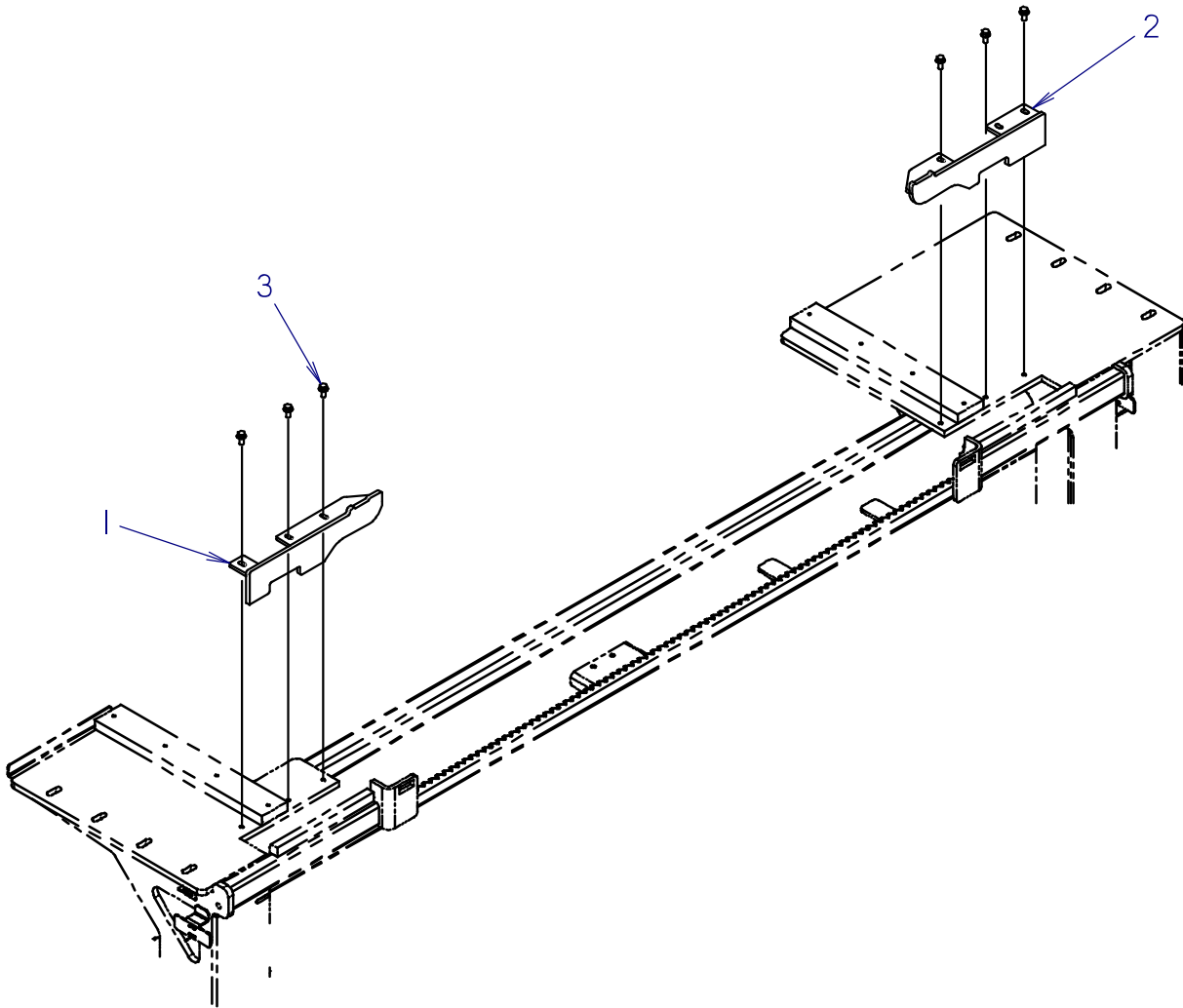

PIPELOADER CHUTES

REF NO.	PART NUMBER	QTY	DESCRIPTION	REMARKS
1	300-2879	1	FRONT CHUTE	
2	300-2883	1	REAR CHUTE	
3	106-806	6	FLG LK SCREW (M2-1.75 X 25MM)	USE LOCTITE 242 OR EQUIVALENT

NOT SHOWN:

FOOTNOTES:

NOTE:

JT CHUTE OPENING - 3.35"
AT CHUTE OPENING - 3.60"

PIPELOADER CONTROLLER MOUNT

BEGINS WITH S/N CMWJ30ATEA0000222

BEGINS WITH S/N CMWJ30M1LA0000356

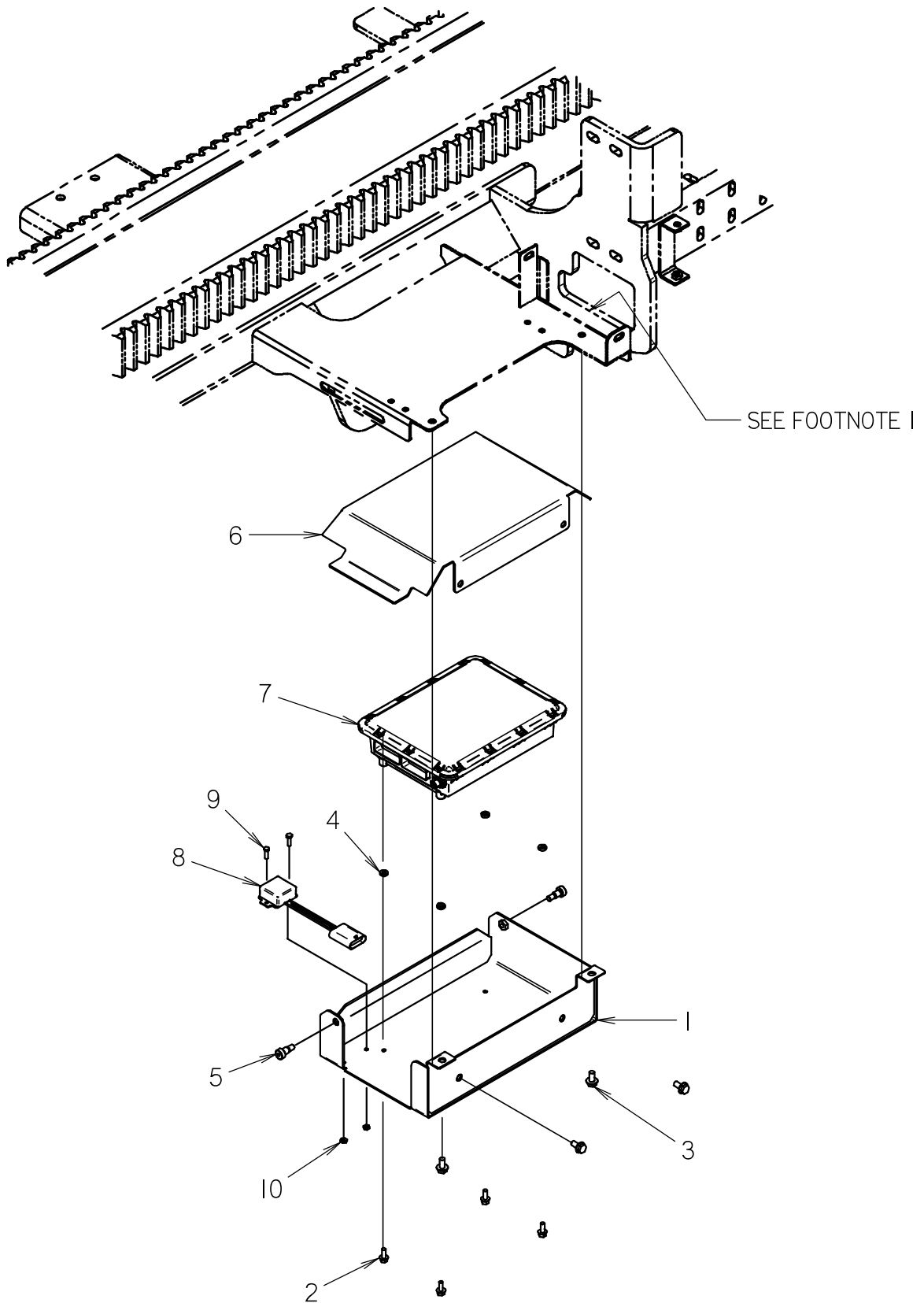

PIPELOADER CONTROLLER MOUNT

BEGINS WITH S/N CMWJ30ATEA0000222

BEGINS WITH S/N CMWJ30M1LA0000356

REF NO.	PART NUMBER	QTY	DESCRIPTION	REMARKS
1	300-1332	1	CONTROLLER MOUNT	
2	106-712	4	FLG SCREW (M6-1.00 X 16MM)	
3	106-380	4	FLG LK SCREW (M8-1.25 X 16MM)	
4	155-751	4	WASHER (1/4", NEOPRENE)	
5	107-746	2	SHLD BLT (M10 X 12MM, M8-1.25)	
6	300-4006	1	COVER	
7	220-1009	1	JT CONTROLLER W/CAN	
8	211-277	1	1.0V-2.0V RESISTOR DIMDER	
9	107-781	2	HEX SCREW (#10-24 X 5/8")	
10	105-811	2	LOCKNUT (#10-24)	

NOT SHOWN:

FOOTNOTES:

1. USE 8" 116-259 ON BOTTOM EDGE.

NOTE:

PIPELOADER - MISC.

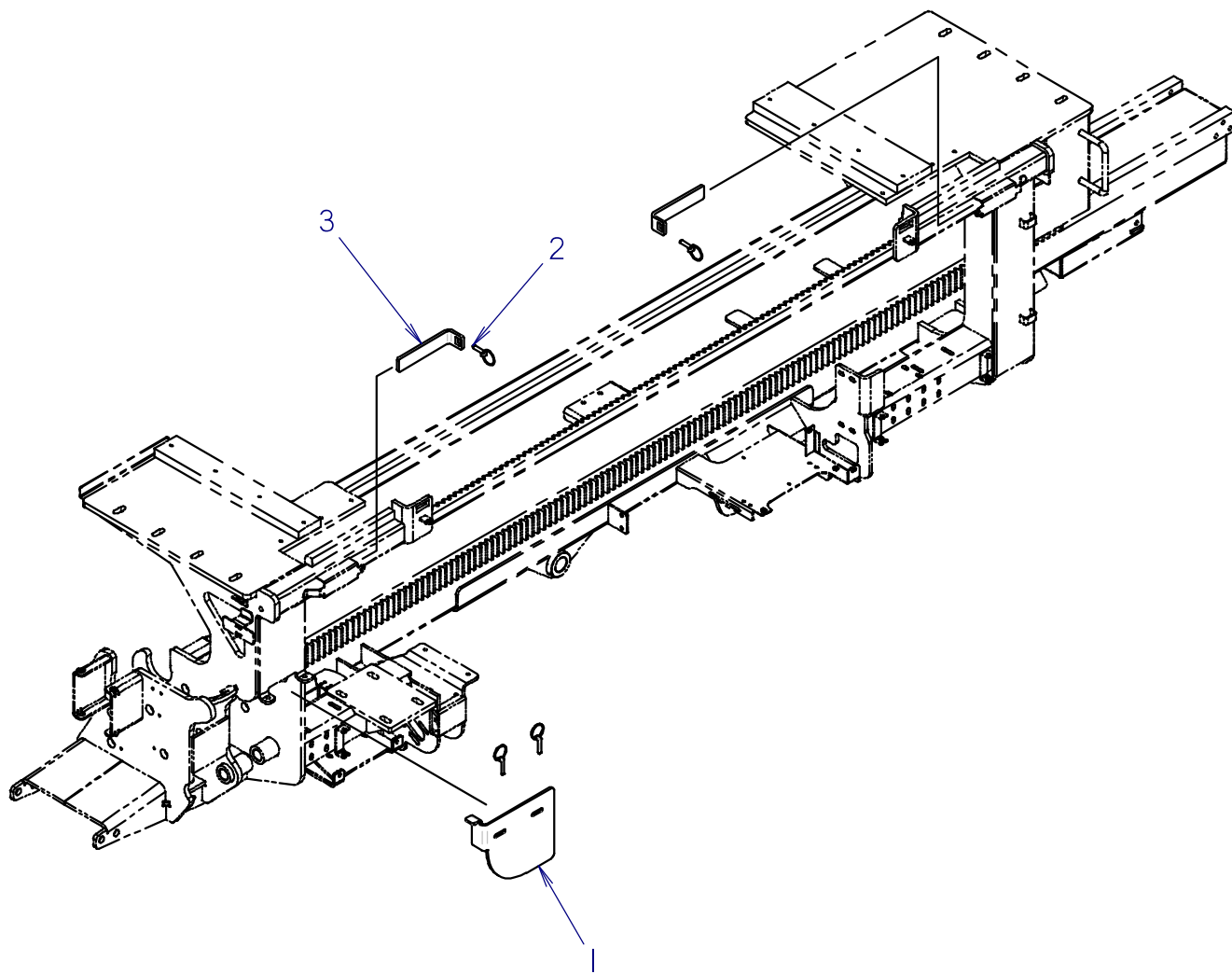

PIPELOADER - MISC.

REF NO.	PART NUMBER	QTY	DESCRIPTION	REMARKS
1	300-2785	1	SINGLE PIPE GUIDE	SEE FOOTNOTE 1
2	110-228	4	LYNCH PIN (7/16" X 2")	
3	300-2164	2	SUPPORT PIN	

NOT SHOWN:

FOOTNOTES:

1. USED FOR SINGLE PIPE LOADING

NOTE:

PIPEBOX SPACER

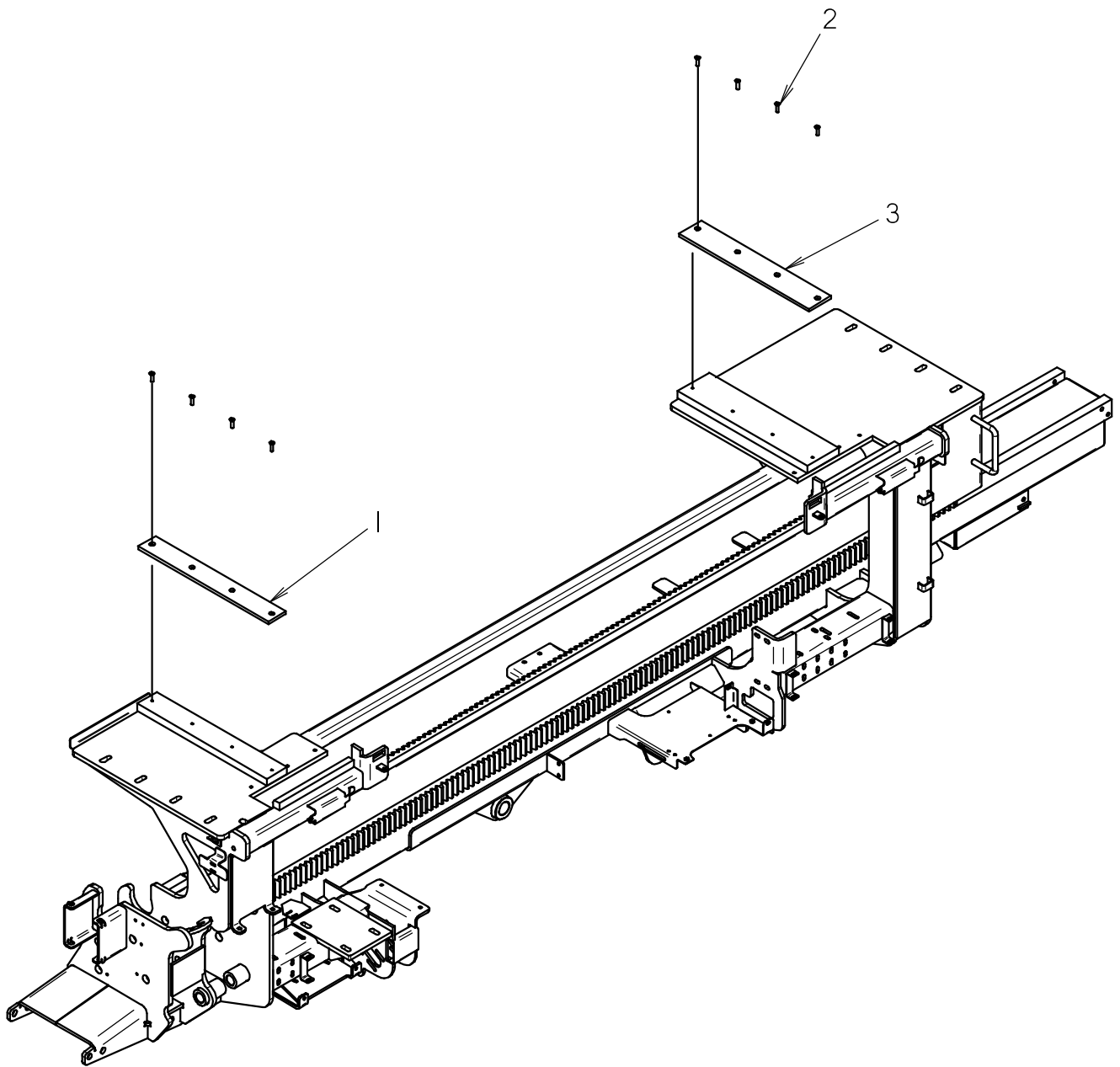

PIPEBOX SPACER

REF NO.	PART NUMBER	QTY	DESCRIPTION	REMARKS
1	362-1058	1	SPACER BAR	
2	105-1181	8	SCREW (M10-1.50 X 35MM CSK SOC)	
3	300-4820	1	SPACER BAR (REAR)	

NOT SHOWN:

FOOTNOTES:

NOTE:

CAB

CAB MOUNTING

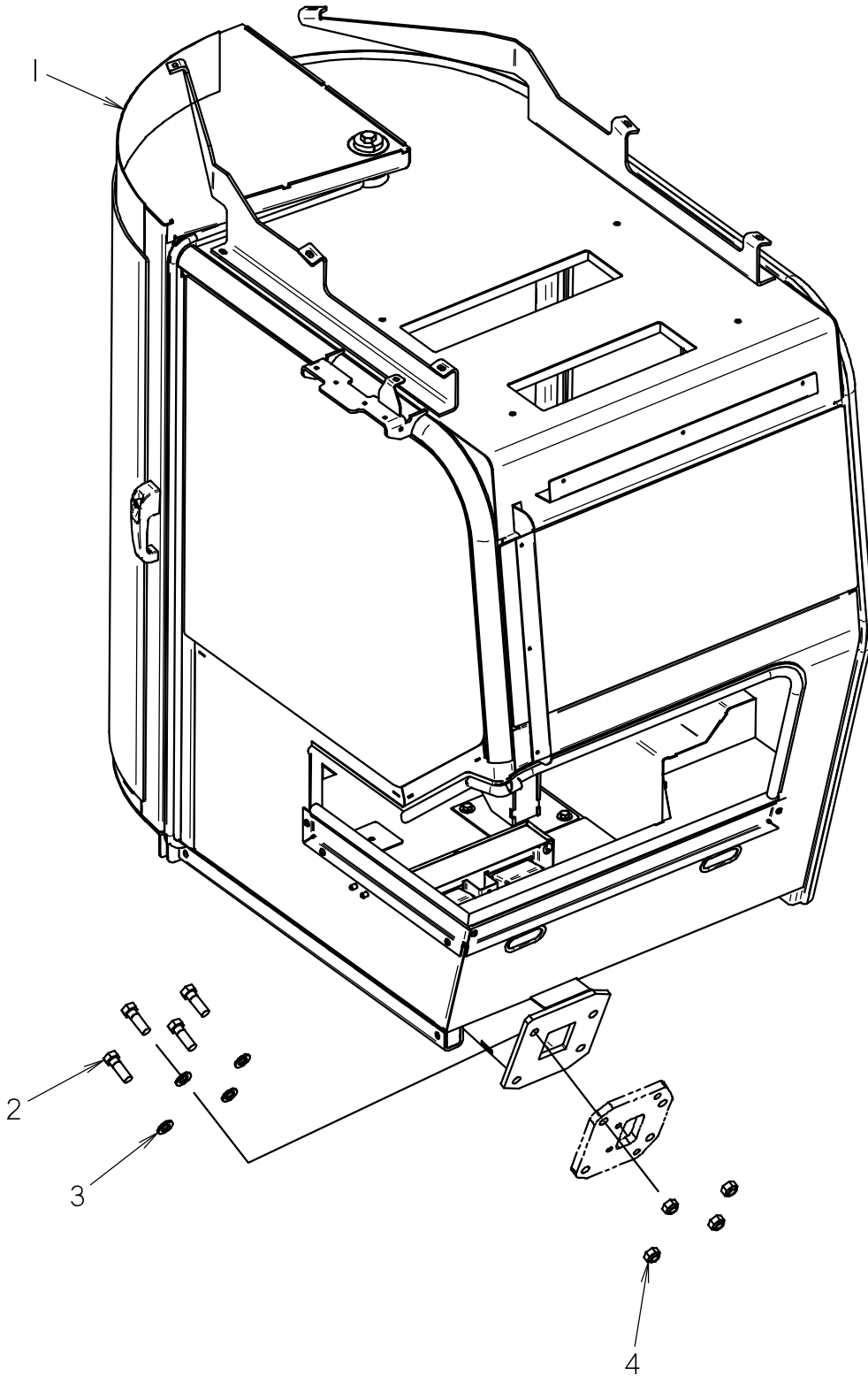

CAB MOUNTING

REF NO.	PART NUMBER	QTY	DESCRIPTION	REMARKS
1	300-6130	1	CAB FRAME	
2	I06-075	4	SCREW (M20-2.50 X 60MM, I0.9)	USE LOCTITE 242 OR EQUIVALENT
3	I06-399	4	WASHER (M20, HARDENED)	
4	I06-665	4	LOCKNUT (M20-2.50, I0.9)	

NOT SHOWN:

FOOTNOTES:

NOTE:

SUPPORT ARM

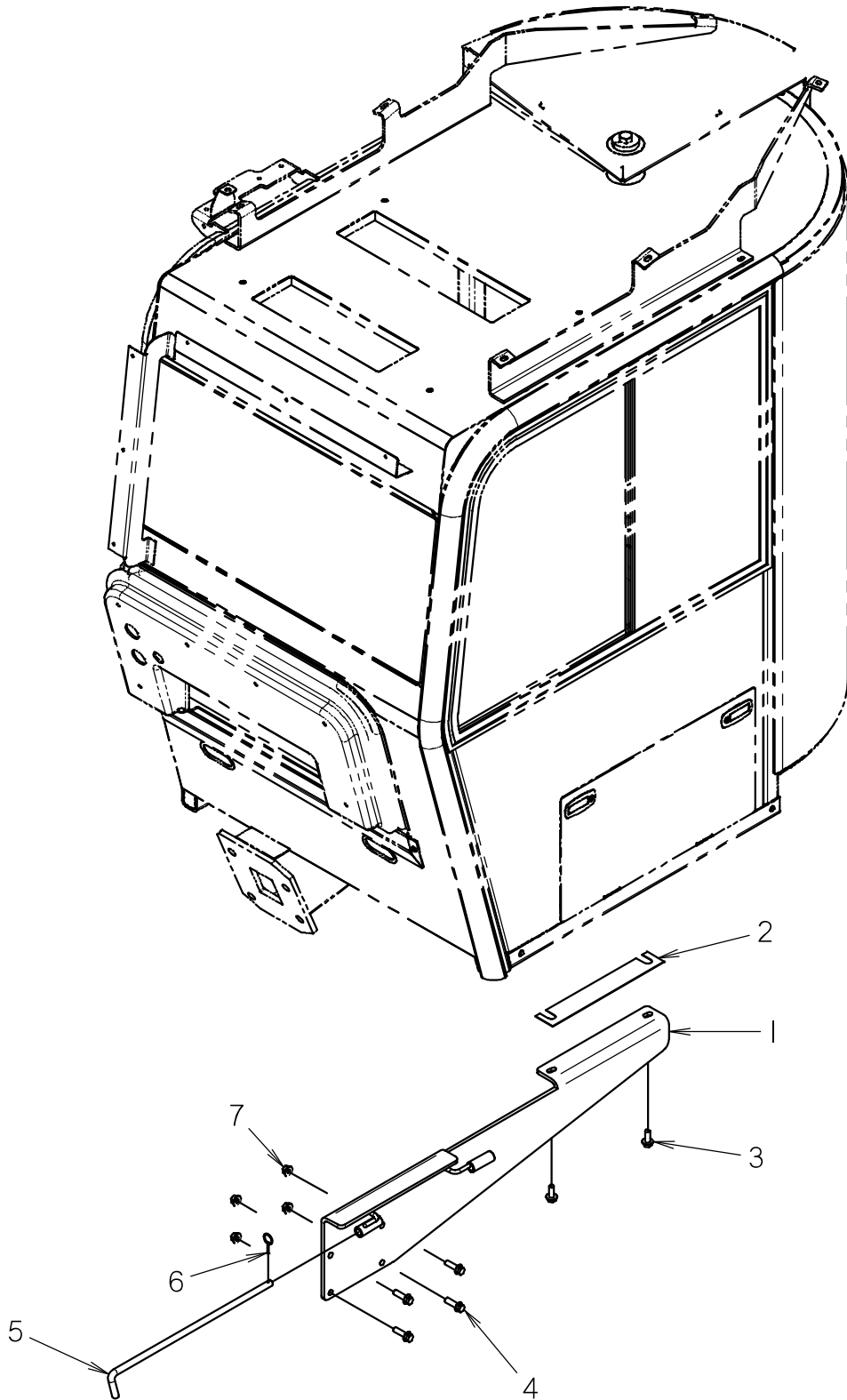

SUPPORT ARM

REF NO.	PART NUMBER	QTY	DESCRIPTION	REMARKS
1	300-6151	1	SUPPORT ARM	ATTACH TO RIGHT TRACK FRAME
2	300-6152	1	SHIM	
3	107-010	2	FLG LK SCREW (M12-1.75 X 30MM)	
4	107-565	4	FLG LK SCREW (M12-1.75 X 40MM)	
5	300-6153	1	VOLTAGE STAKE	
6	110-284	1	PULL PIN (3/16" X 13/16")	
7	106-709	4	FLG LK NUT (M12-1.75)	

NOT SHOWN:

FOOTNOTES:

NOTE:

SEAT

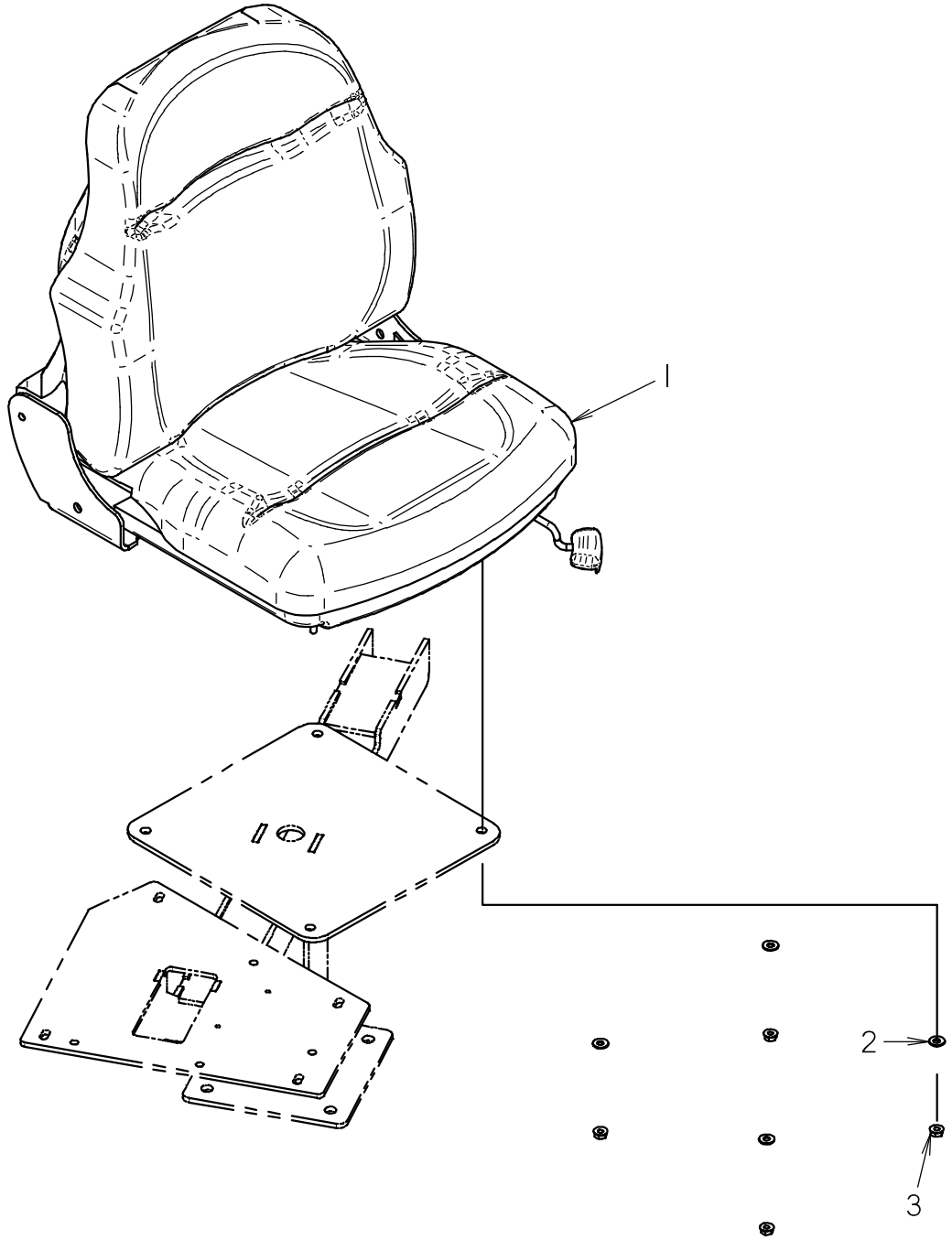

SEAT

REF NO.	PART NUMBER	QTY	DESCRIPTION	REMARKS
1	117-631	1	SEAT ASSEMBLY	
2	105-095	4	WASHER (1/4")	
3	105-003	4	FLG LOCKNUT (5/16-NC)	

NOT SHOWN:

FOOTNOTES:

NOTE:

BATTERY COMPARTMENT

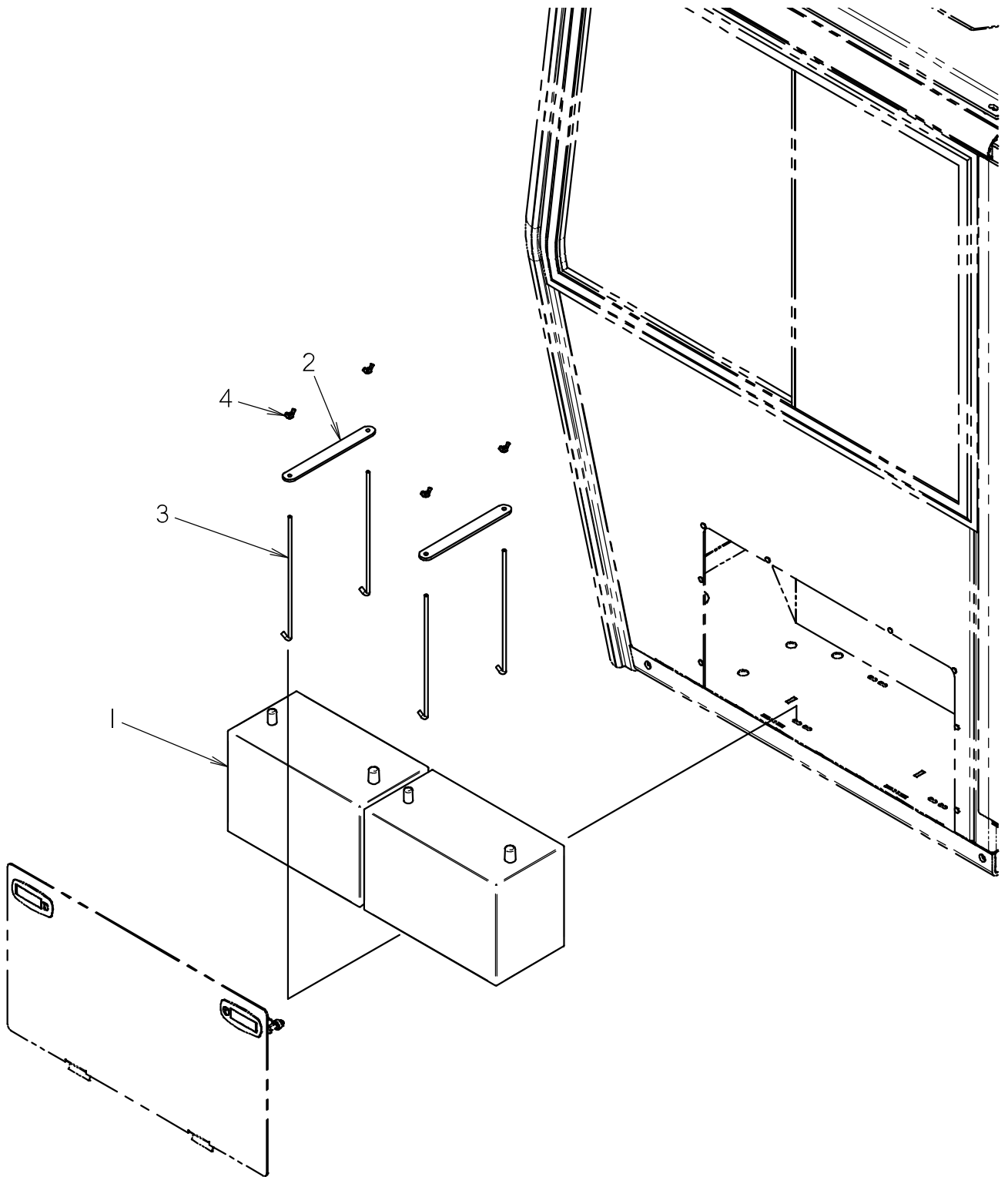

BATTERY COMPARTMENT

REF NO.	PART NUMBER	QTY	DESCRIPTION	REMARKS
1	215-262	2	BATTERY (12V, 925 AMP)	
2	108-189	2	BATTERY HOLD DOWN	
3	337-001	4	BATTERY BOLT	
4	195-339	4	WING NUT (1/4-NC)	

NOT SHOWN:

215-1443 | BATTERY CABLE
 215-1444 | BATTERY CABLE

FOOTNOTES:

NOTE:

HEATER

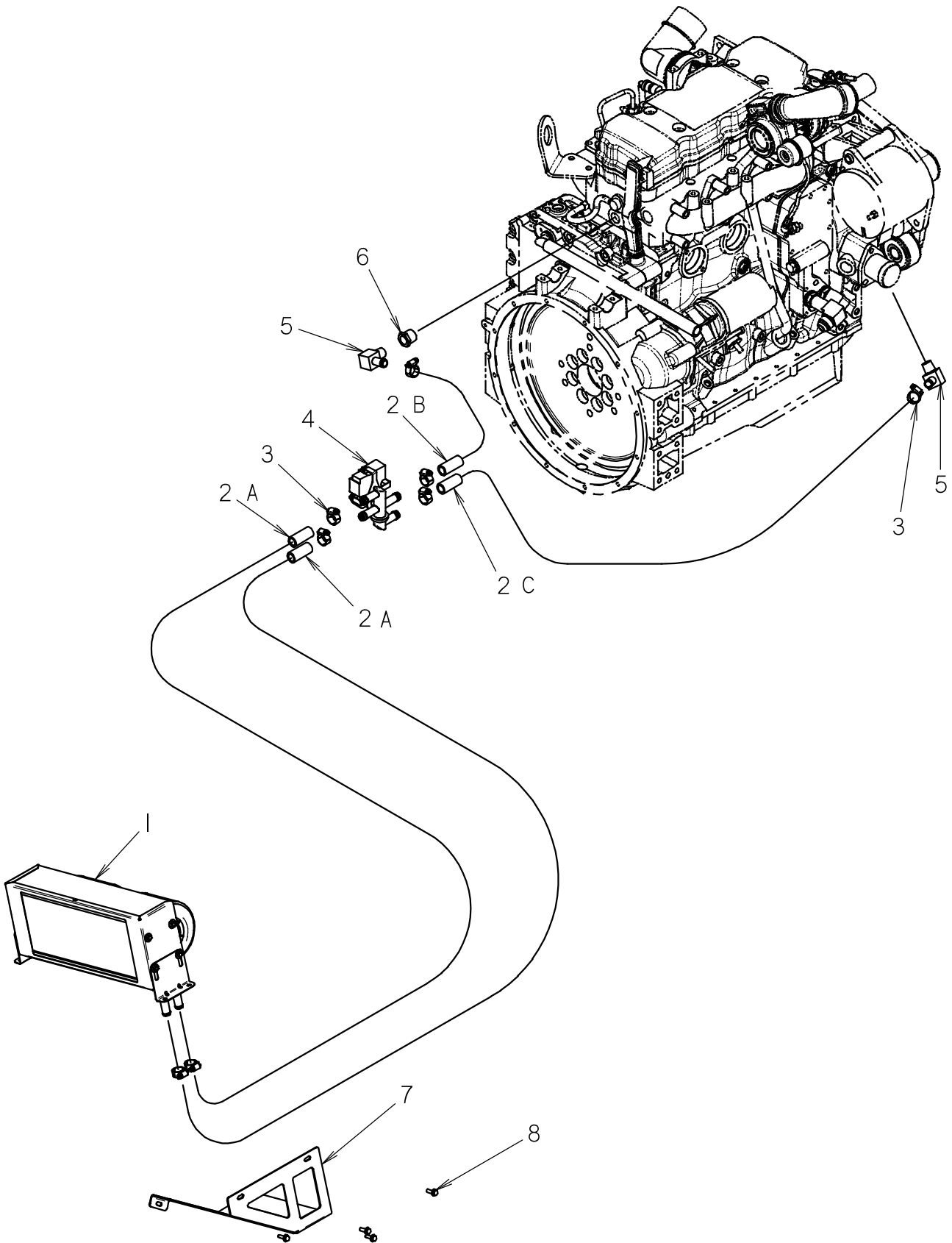

HEATER

REF NO.	PART NUMBER	QTY	DESCRIPTION	REMARKS
1	500-1623	1	HEATER	
2	116-750	189	BULK HOSE (5/8", SOLD PER 1')	SEE FOOTNOTE 1
3	110-217	8	WORM CLAMP (7/16" TO 1")	
4	499-705	1	HEATER VALVE MOTOR	
5	514-285	2	S/O COUPLER (08N-10H90)	
6	115-126	1	REDUCER (12N-08NF)	
7	500-1725	1	SKID PLATE	
8	106-161	4	FLG SCREW (M6-1.00 X 20MM)	

NOT SHOWN:

500-1726 | SWITCH, BLOWER
 500-2013 | KNOB, BLOWER SWITCH

FOOTNOTES:

LENGTHS USED AND QUANTITY

A - 2 @ 71"
 B - 1 @ 15"
 C - 1 @ 32"

NOTE:

AC COMPONENTS

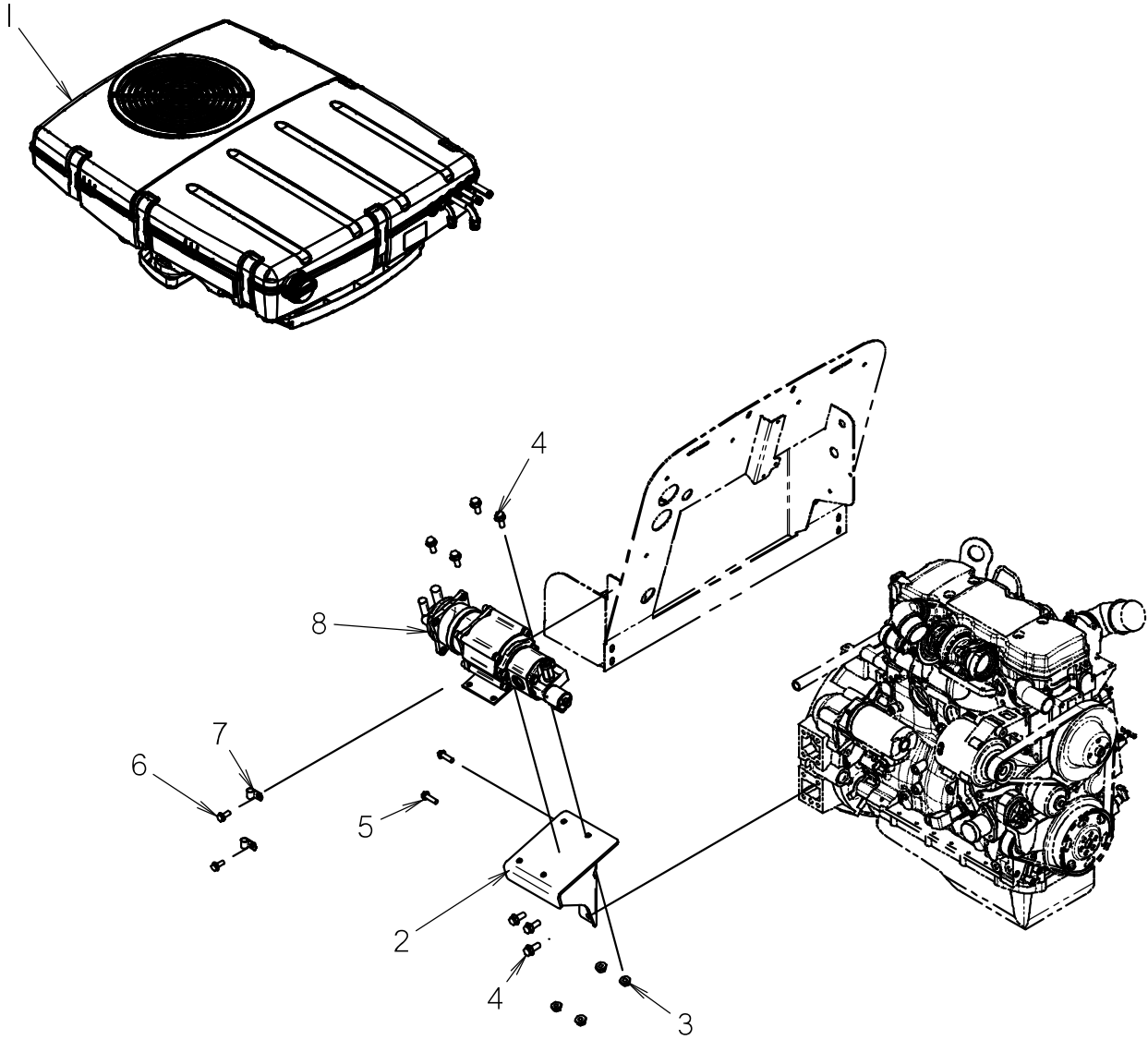

AC COMPONENTS

REF NO.	PART NUMBER	QTY	DESCRIPTION	REMARKS
1	500-1622	1	A/C UNIT	
2	300-6150	1	COMPRESSOR MOUNT	
3	106-709	4	FLG LK NUT (M12-I.75)	
4	106-469	7	FLG SCREW (M12-I.75 X 30MM)	
5	106-497	2	FLG SCREW (M10-I.50 X 35MM)	
6	106-724	2	FLG SCREW (M10-I.50 X 25MM)	
7	110-259	2	BOLT-ON CLAMP (.625")	
8	150-2189	1	HYDRAULIC COMPRESSOR	25 OZ REFRIDGERANT

NOT SHOWN:

FOOTNOTES:

NOTE:

CANOPY

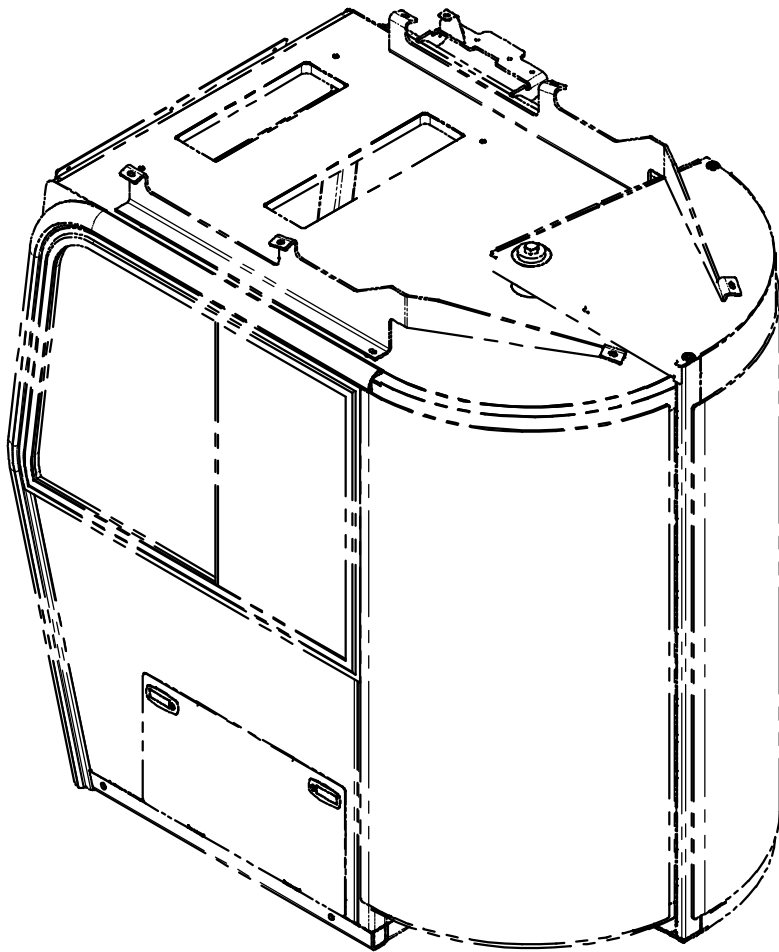
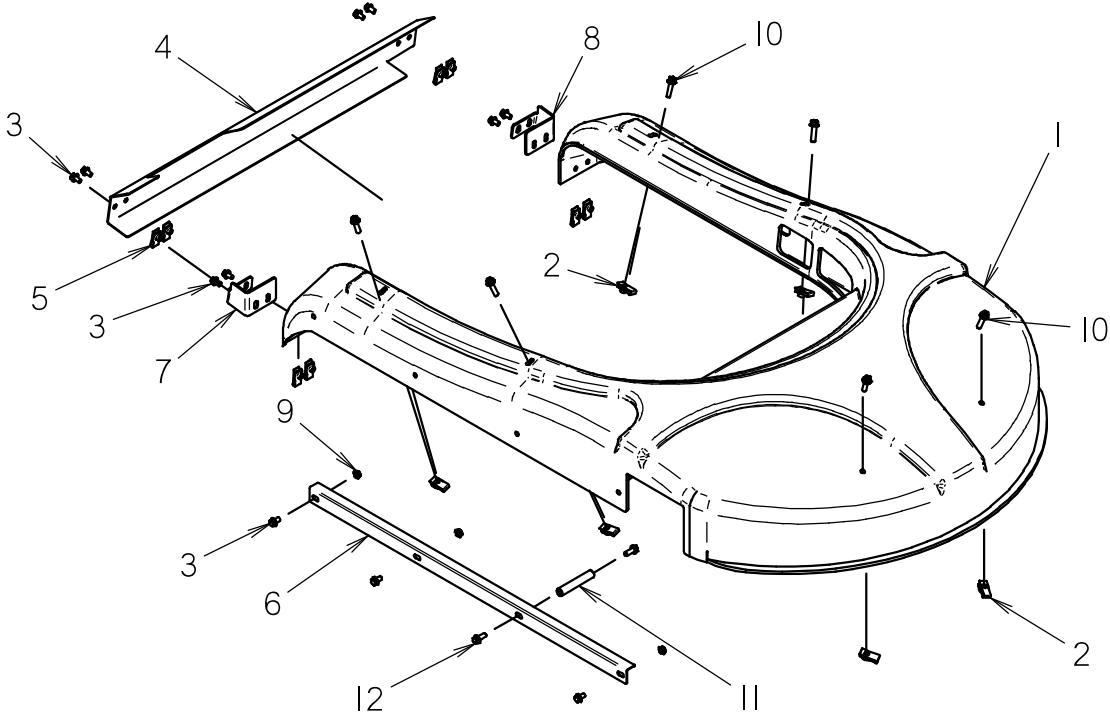

CANOPY

REF NO.	PART NUMBER	QTY	DESCRIPTION	REMARKS
I	362-1309	1	CANOPY	
2	107-011	6	CLIP NUT (3/8-NC)	
3	501-153	II	FLG LK BOLT (3/8-NC X 5/8")	
4	300-8519	I	REAR PANEL	
5	105-260	8	CLIP NUT (3/8-NC)	
6	300-8530	I	BRACKET	
7	300-8280	I	BRACKET	
8	300-8279	I	BRACKET	
9	105-834	3	FLG LOCKNUT (3/8-NC)	
10	105-874	6	FLG LK BOLT (3/8-NC X 1-1/2")	
II	300-8587	I	SUPPORT BAR	
12	105-826	2	FLG LK BOLT (3/8-NC X 1")	

NOT SHOWN:

FOOTNOTES:

NOTE:

TOOL TRAY

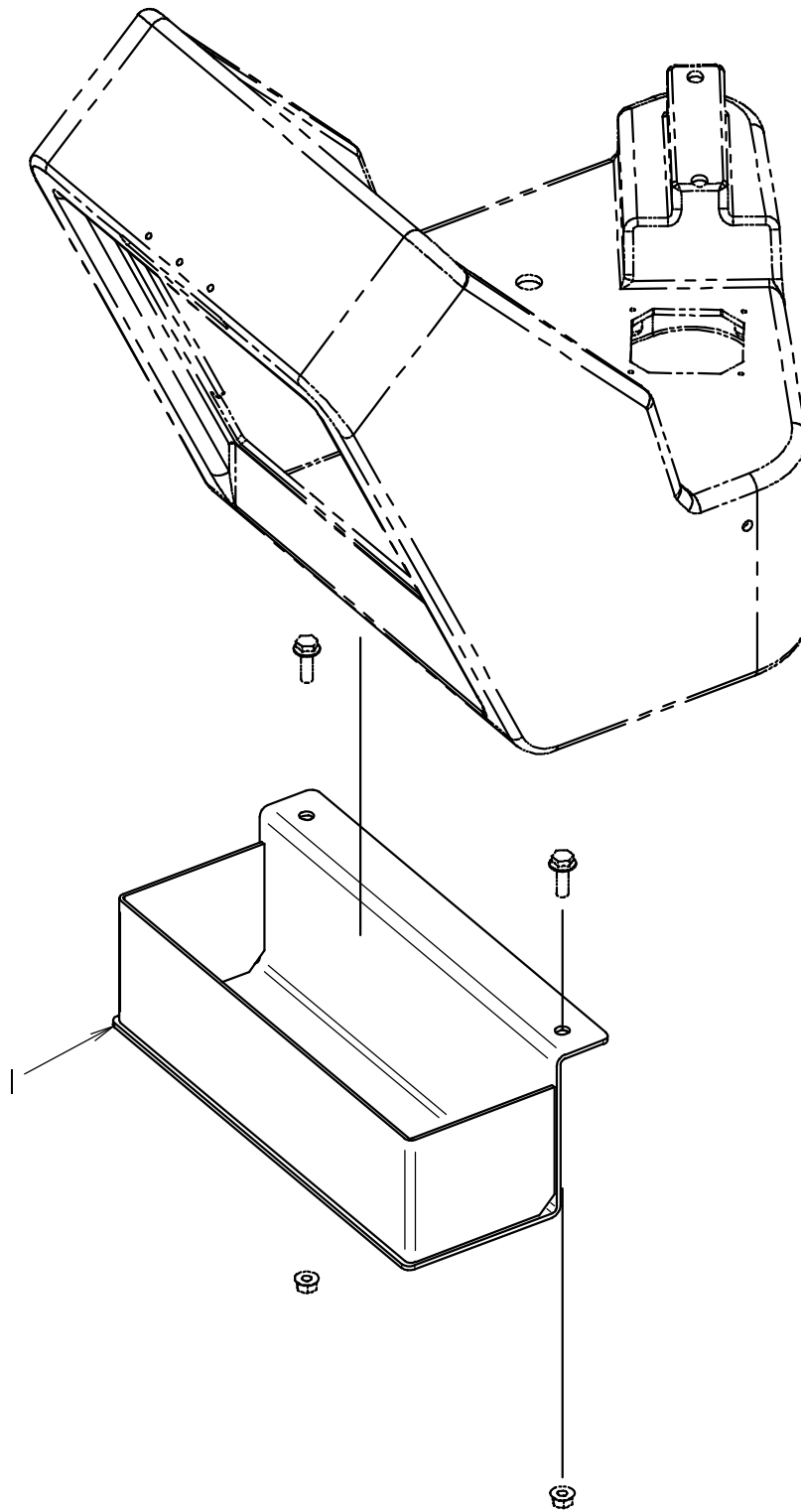

TOOL TRAY

REF NO.	PART NUMBER	QTY	DESCRIPTION	REMARKS
I	300-6224	I	TOOL TRAY	USE EXISTING HARDWARE FROM RIGHT CONSOLE

NOT SHOWN:

FOOTNOTES:

NOTE:

01

ID0215229

AC HYDRAULICS

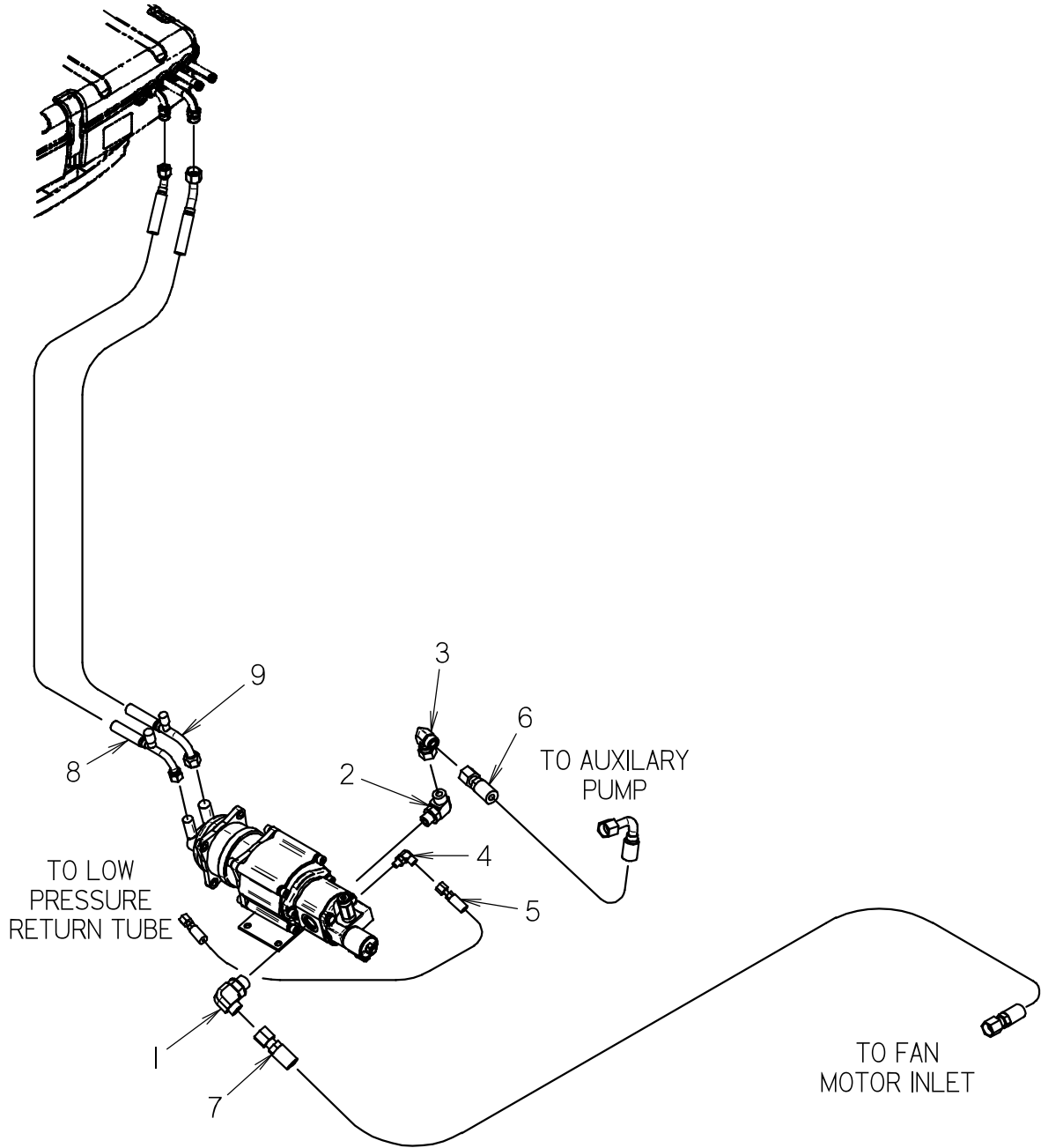

AC HYDRAULICS

REF NO.	PART NUMBER	QTY	DESCRIPTION	REMARKS
1	I54-300	1	CONNECTOR (I00-I2S90)	
2	I54-298	1	CONNECTOR (I0S-I0090)	
3	I54-315	1	UNION (I00-I00FX90)	
4	I54-252	1	CONNECTOR (04S-04090)	
5	I54-653	1	HOSE (040FX-40"-3000)	
6	I50-2709	1	HOSE (I00FX90L-65"-4000)	
7	515-202	1	HOSE (I00FX-I06"-3000)	
8	I50-2716	1	AC HOSE (L-08 90 W/PORT, -08 45, 75.5")	
9	I50-2717	1	AC HOSE (L-I0 90 W/PORT, -I0 45, 75.5")	

NOT SHOWN:

FOOTNOTES:

NOTE:

AC FUSE BLOCK MOUNTING

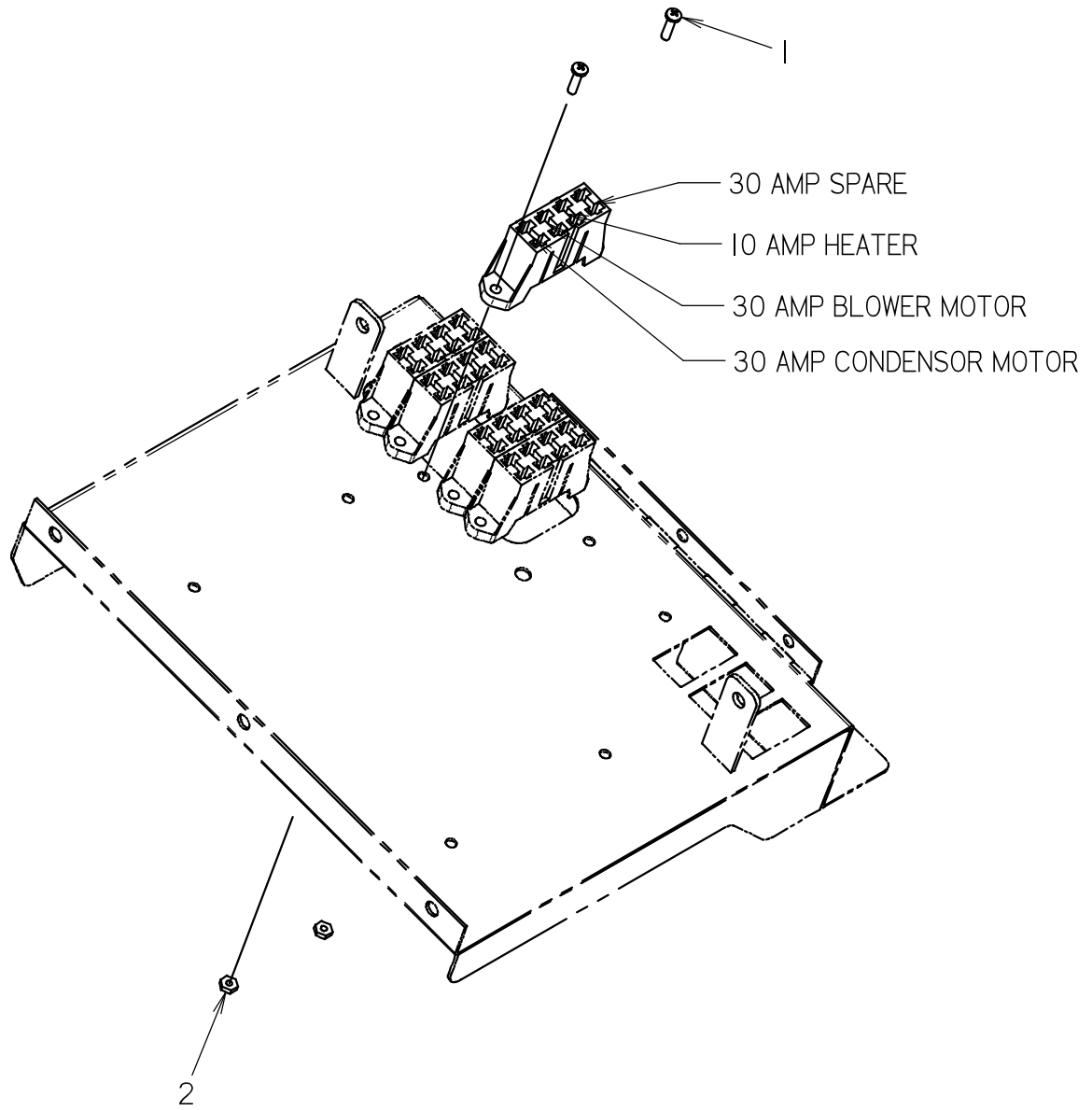

AC FUSE BLOCK MOUNTING

REF NO.	PART NUMBER	QTY	DESCRIPTION	REMARKS
1	106-049	2	BOLT (#10-24 X 3/4", PLPS)	
2	106-048	2	LOCKNUT (#10-24)	

NOT SHOWN:

217-701 1 RELAY
106-231 2 SCREW (M6-1.00 X 16MM)
106-385 2 FLG LOCKNUT (M6-1.00)

FOOTNOTES:**NOTE:**

CAB WORKING LIGHTS

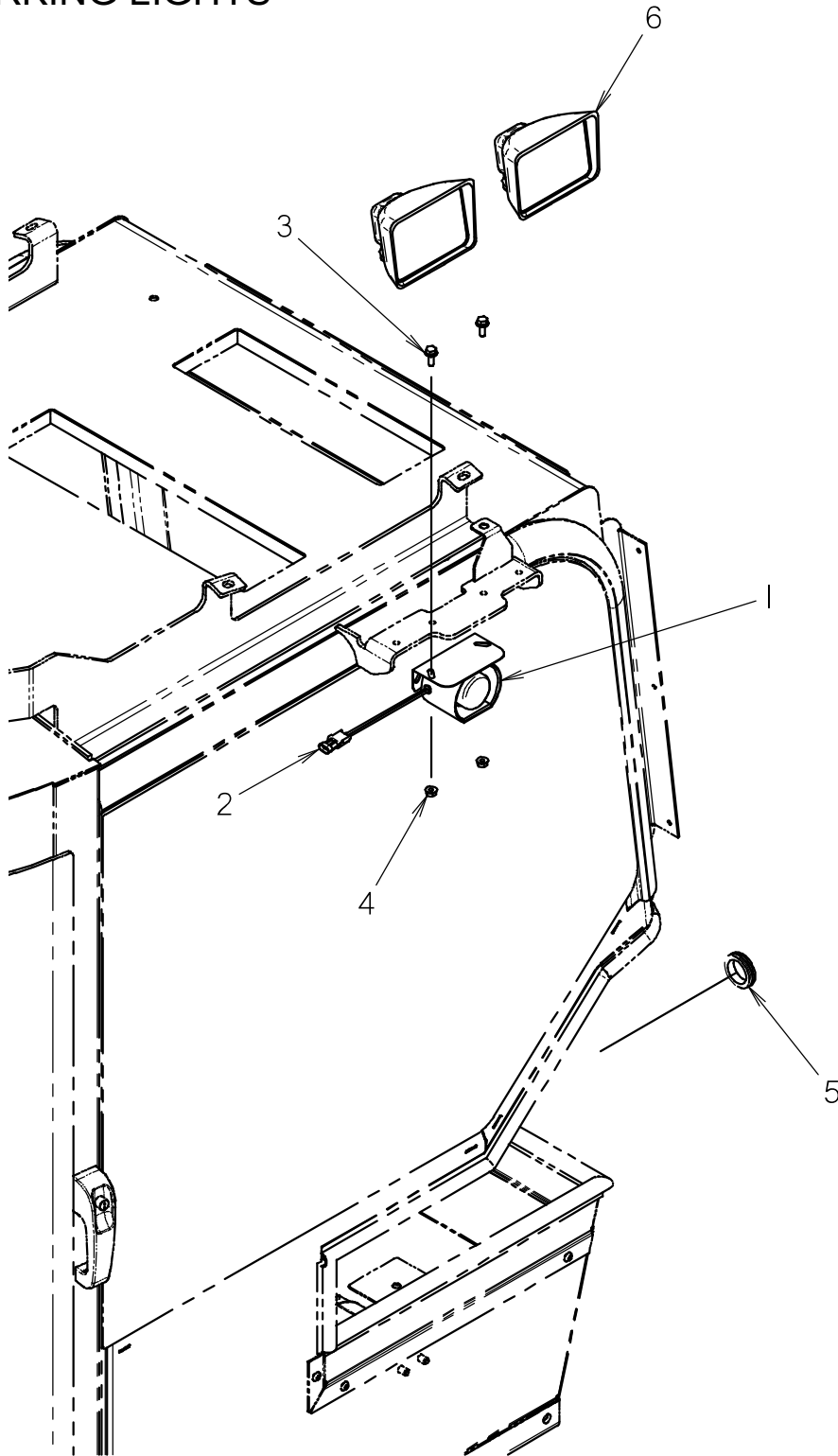

CAB WORKING LIGHTS

REF NO.	PART NUMBER	QTY	DESCRIPTION	REMARKS
1	306-602	1	ALARM	
2	214-103	1	(2-WAY) MALE CONNECTOR	
3	106-162	2	FLG SCREW (M8-1.25 X 20MM, GD8)	
4	106-386	2	FLG LOCKNUT (M8-1.25)	
5	115-320	1	GROMMET (1-1/2")	USED ON FRONT FIREWALL
6	217-057	2	WORKING LIGHT - CLEAR	

NOT SHOWN:

FOOTNOTES:

NOTE:

CAB SERVICE PARTS

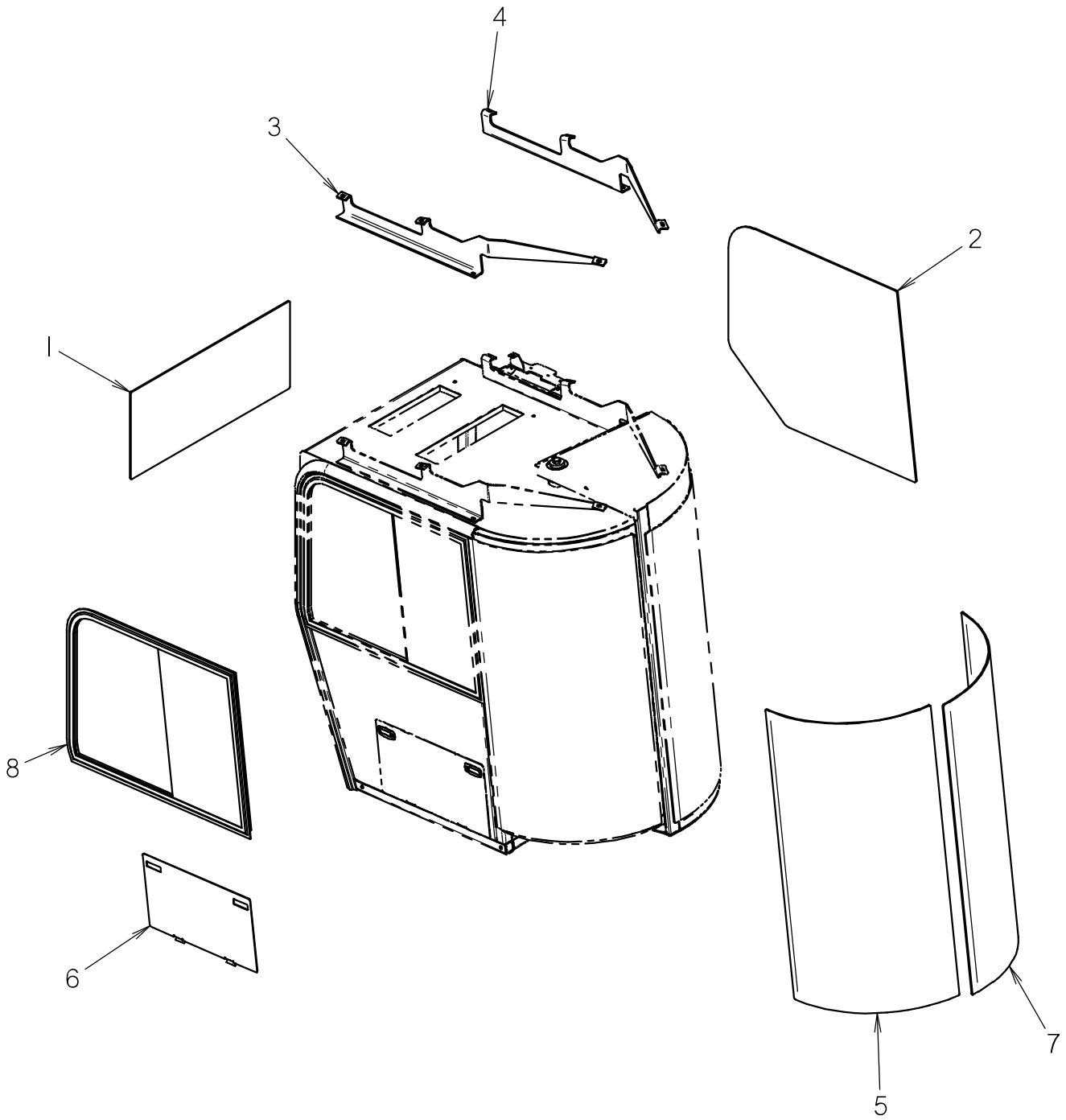

CAB SERVICE PARTS

REF NO.	PART NUMBER	QTY	DESCRIPTION	REMARKS
1	500-1628	1	REAR WINDOW	
2	500-1629	1	LEFT WINDOW	
3	500-1631	1	RIGHT CANOPY MOUNT	
4	500-1630	1	LEFT CANOPY MOUNT	
5	500-1635	1	FRONT WINDSHIELD (FIXED)	
6	500-1633	1	DOOR	USES 2X 117-558 LATCH
7	500-1634	1	FRONT WINDSHIELD (MOVING)	
8	500-1632	1	RIGHT WINDOW	

NOT SHOWN:

FOOTNOTES:

NOTE:

ACCESSORIES

ANTIFREEZE TANK

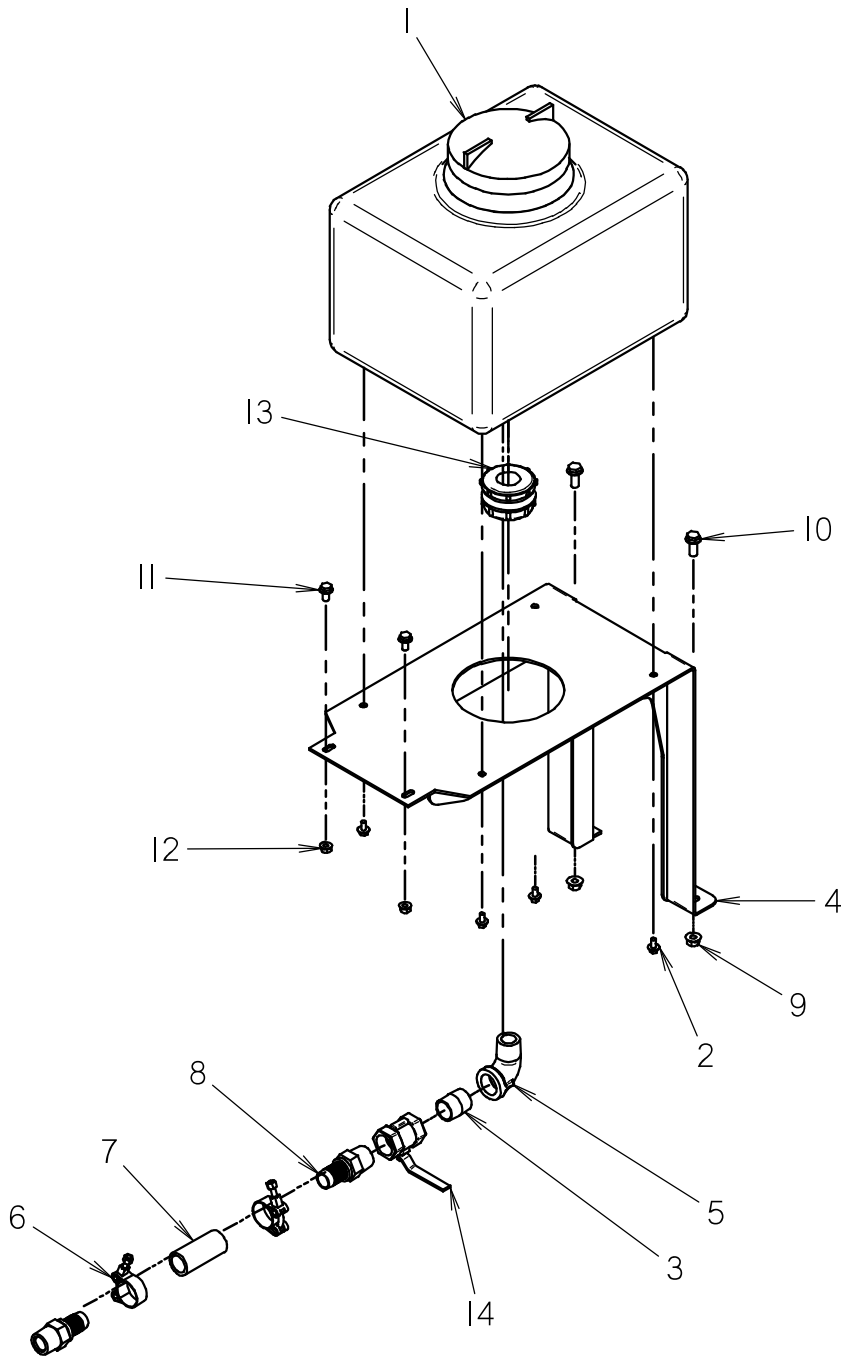

ANTIFREEZE TANK

REF NO.	PART NUMBER	QTY	DESCRIPTION	REMARKS
1	364-515	1	WATER TANK (8 GAL)	
2	105-836	4	FLG LK BOLT (1/4-NC X 1/2")	
3	115-1016	1	ALL THREAD (16N)	
4	329-749	1	TANK MOUNT	
5	115-440	1	STREET ELBOW (16N-16NF90)	
6	111-027	2	T-BOLT CLAMP (1.25" - 1.50")	
7	116-460	15	BULK HOSE (1", SOLD PER FT)	
8	155-136	2	S/O COUPLER (16N-16H)	
9	106-387	2	FLG LOCKNUT (M10-1.50)	
10	106-724	2	FLG SCREW (M10-1.50 X 25MM)	
11	106-380	2	FLG LK SCREW (M8-1.25 X 16MM)	
12	106-386	2	FLG LOCKNUT (M8-1.25)	
13	157-490	1	BK CONNECTOR (16NF POLY)	
14	514-318	1	SHUT-OFF (16NF-16NF)	

NOT SHOWN:

FOOTNOTES:

NOTE:

CANOPY

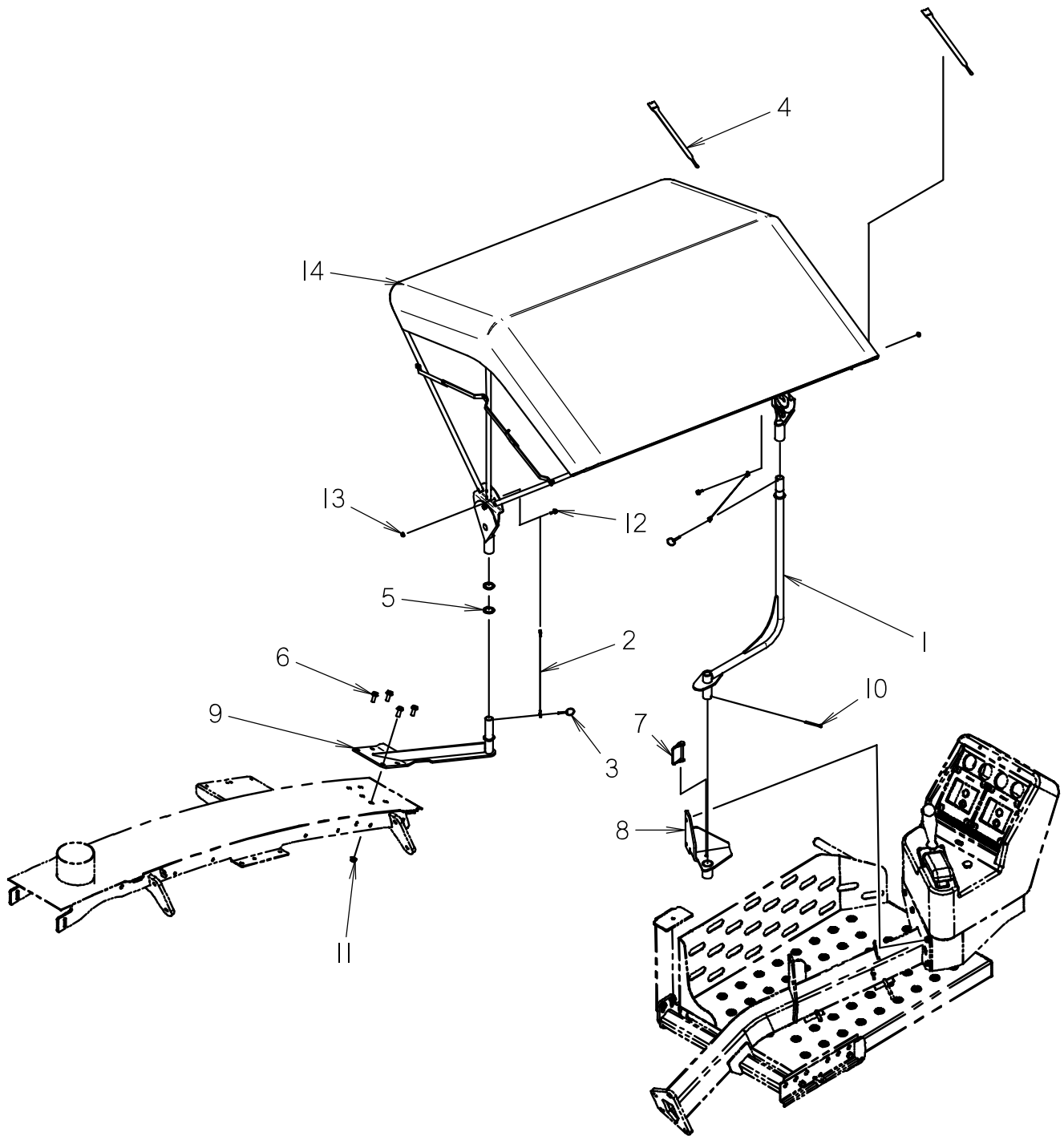

CANOPY

REF NO.	PART NUMBER	QTY	DESCRIPTION	REMARKS
1	324-508	1	OUTER MOUNT	
2	110-239	2	LANYARD CABLE (13.5")	
3	110-284	2	PULL PIN (3/16" X 13/16")	
4	118-341	2	VELCRO STRAP	
5	110-078	2	MACH. BUSHING (1", 14GA)	
6	106-724	4	FLG SCREW (M10-1.50 X 25MM)	
7	110-032	1	SNAPPER PIN (5/16" X 2-1/2")	
8	300-2380	1	OUTER MOUNT	
9	300-2376	1	HOOD MOUNT	
10	105-502	1	COTTER PIN (3/16" X 2")	
11	106-387	4	FLG LOCKNUT (M10-1.50)	
12	106-712	2	FLG SCREW (M6-1.00 X 16MM)	
13	106-385	2	FLG LOCKNUT (M6-1.00)	
14	190-1286	1	CANOPY	SUPERSEDES 118-215; FOR SERVICE PARTS SEE FOOTNOTE I

NOT SHOWN:

FOOTNOTES:

I. 500-1531 FRAME; 500-1530 CANVAS COVER

NOTE:

HEATED GREASER

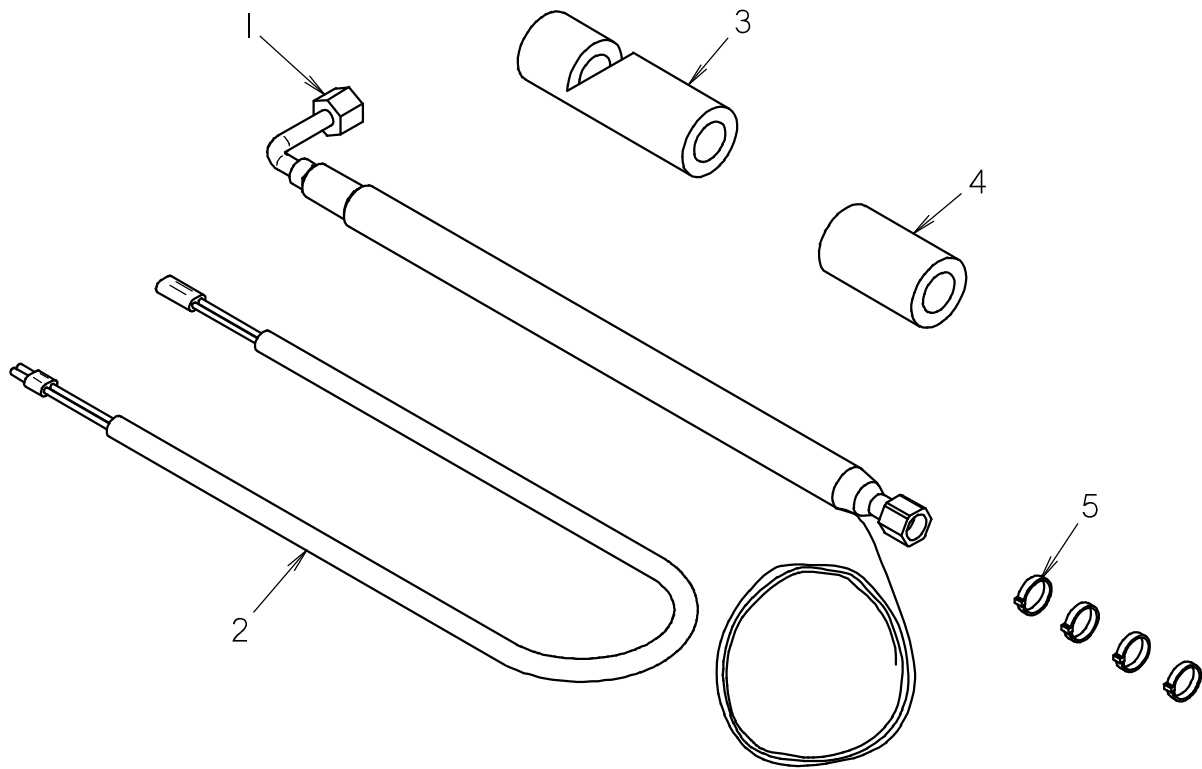

HEATED GREASER

REF NO.	PART NUMBER	QTY	DESCRIPTION	REMARKS
	I90-1300		HEATED HOSE KIT	INCLUDES REF NO.'S I-5
1	I50-2064	1	HOSE (060FX90L-28"-3000, SPECIAL)	
2	214-843	1	GREASER JUMPER HARNESS	
3	117-549	1	INSULATOR (1" ID X 5.00")	
4	117-548	1	PIPE INSULATION	
5	110-030	4	CABLE TIE (1/16" TO 4")	

NOT SHOWN:

FOOTNOTES:

NOTE:

JT PIPE BOX (TALL)

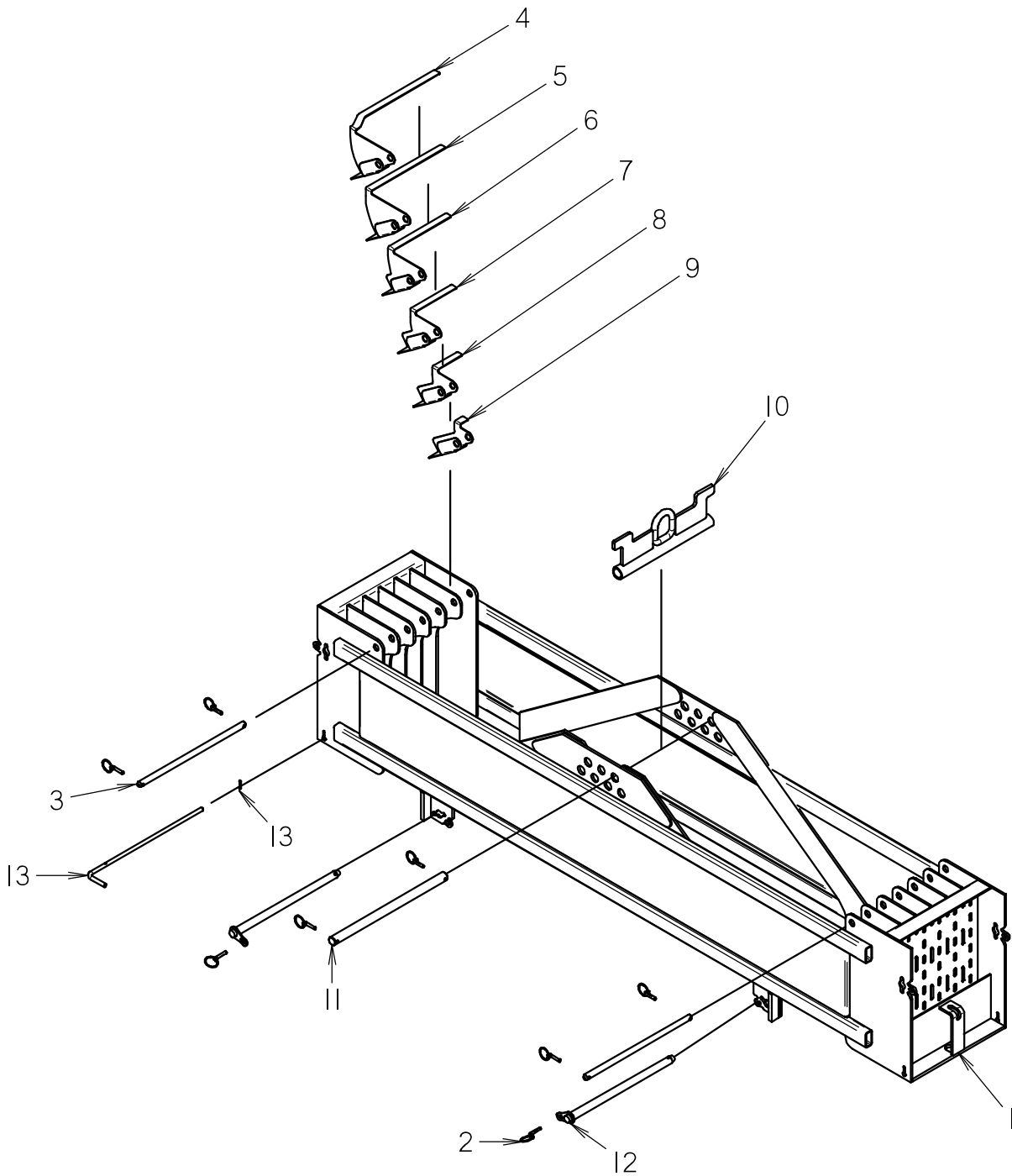

JT PIPE BOX (TALL)

REF NO.	PART NUMBER	QTY	DESCRIPTION	REMARKS
	I90-I136		JT PIPE BOX SUB	
1	329-693	1	JT PIPE BOX	
2	110-228	8	LYNCH PIN (7/16" X 2")	
3	300-I005	2	BAR	
4	300-2299	1	FLAG	
5	300-2298	1	FLAG	
6	300-2297	1	FLAG	
7	300-2296	1	FLAG	
8	300-2295	1	FLAG	
9	300-I007	1	FLAG	
10	300-I728	1	LIFT BLOCK	
11	300-I725	1	LIFT BAR	
12	300-I729	2	PIN	
13	300-2294	1	FRONT PIN	

NOT SHOWN:

FOOTNOTES:

NOTE:

AT PIPE BOX (TALL)

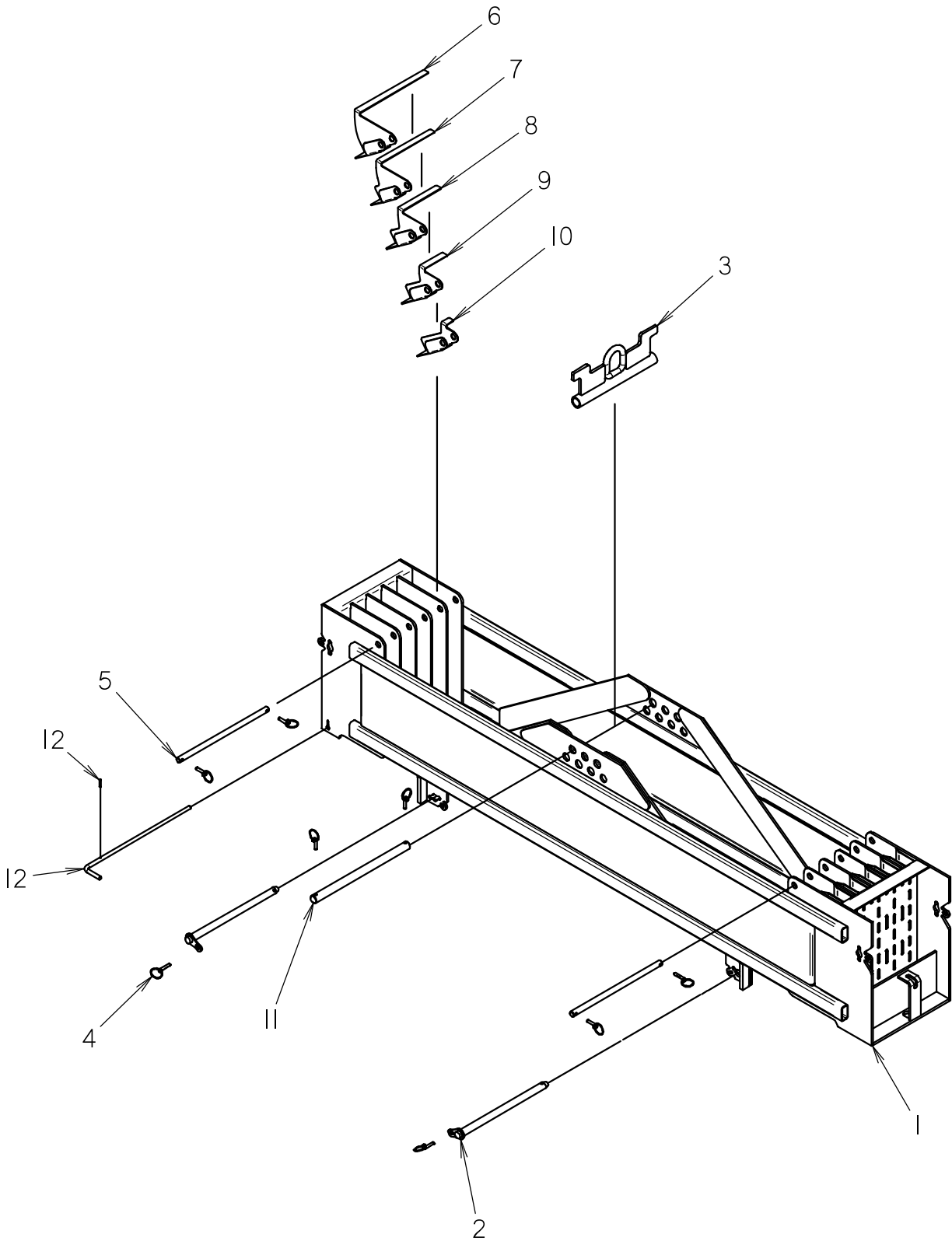

AT PIPE BOX (TALL)

REF NO.	PART NUMBER	QTY	DESCRIPTION	REMARKS
	190-1138		AT PIPE BOX SUB	
1	300-1711	1	AT PIPE BOX	
2	300-1732	2	PIN	
3	313-252	1	LIFT BLOCK	
4	110-228	8	LYNCH PIN (7/16" X 2")	
5	300-1723	2	BAR	
6	300-2298	1	FLAG	
7	300-2297	1	FLAG	
8	300-2296	1	FLAG	
9	300-2295	1	FLAG	
10	300-1007	1	FLAG	
11	300-1724	1	LIFT BAR	
12	300-2294	1	FRONT PIN	

NOT SHOWN:

FOOTNOTES:

NOTE:

JT PIPE BOX (SHORT)

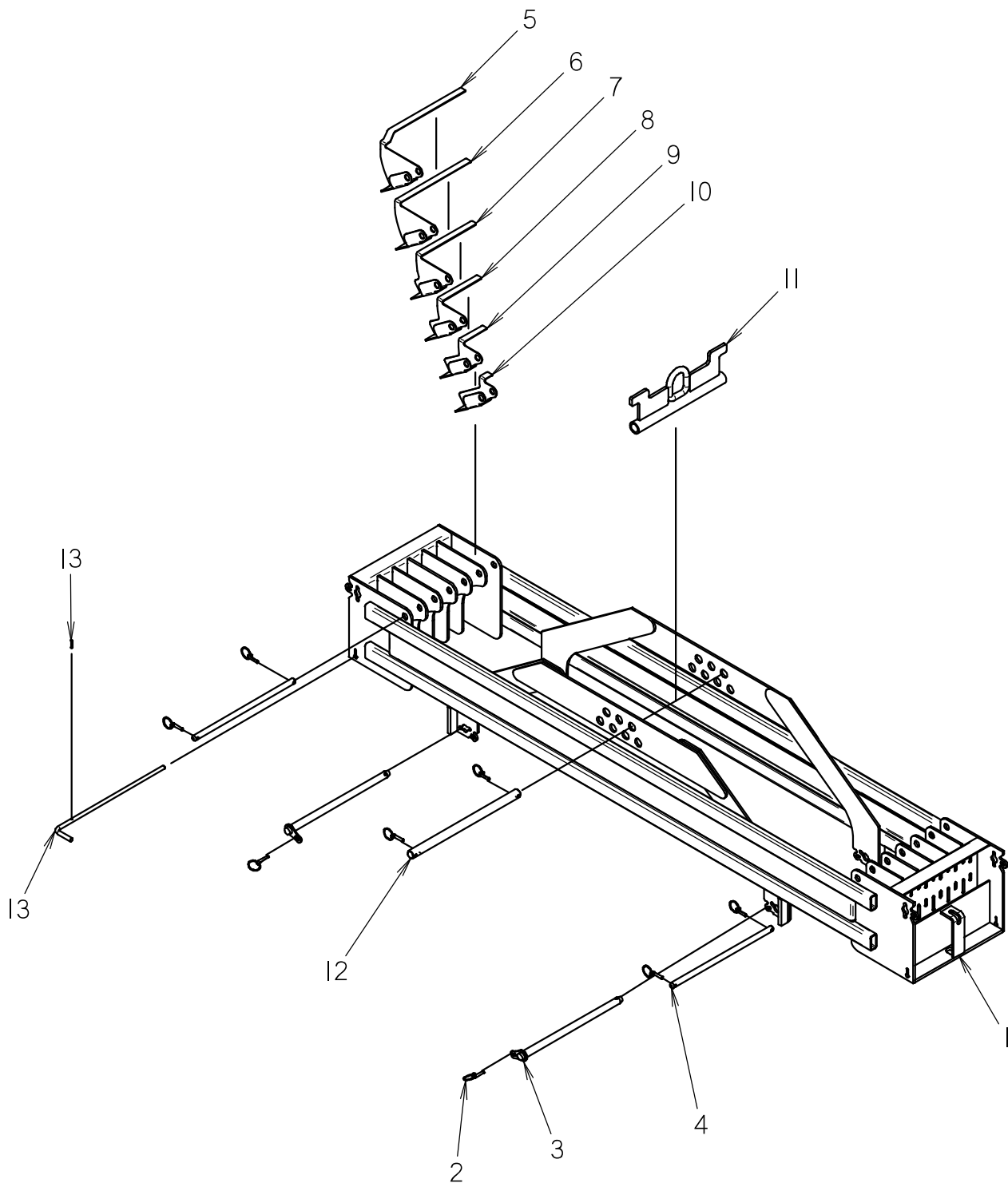

JT PIPE BOX (SHORT)

REF NO.	PART NUMBER	QTY	DESCRIPTION	REMARKS
	I90-I135		JT SHORT PIPE BOX SUB	
1	300-I642	1	JT SHORT PIPE BOX	
2	110-228	8	LYNCH PIN (7/16" X 2")	
3	300-I729	2	PIN	
4	300-I005	2	BAR	
5	300-2299	1	FLAG	
6	300-2298	1	FLAG	
7	300-2297	1	FLAG	
8	300-2296	1	FLAG	
9	300-2295	1	FLAG	
10	300-I007	1	FLAG	
11	300-I728	1	LIFT BLOCK	
12	300-I725	1	LIFT BAR	
13	300-2294	1	FRONT PIN	

NOT SHOWN:

FOOTNOTES:

NOTE:

AT PIPE BOX (SHORT)

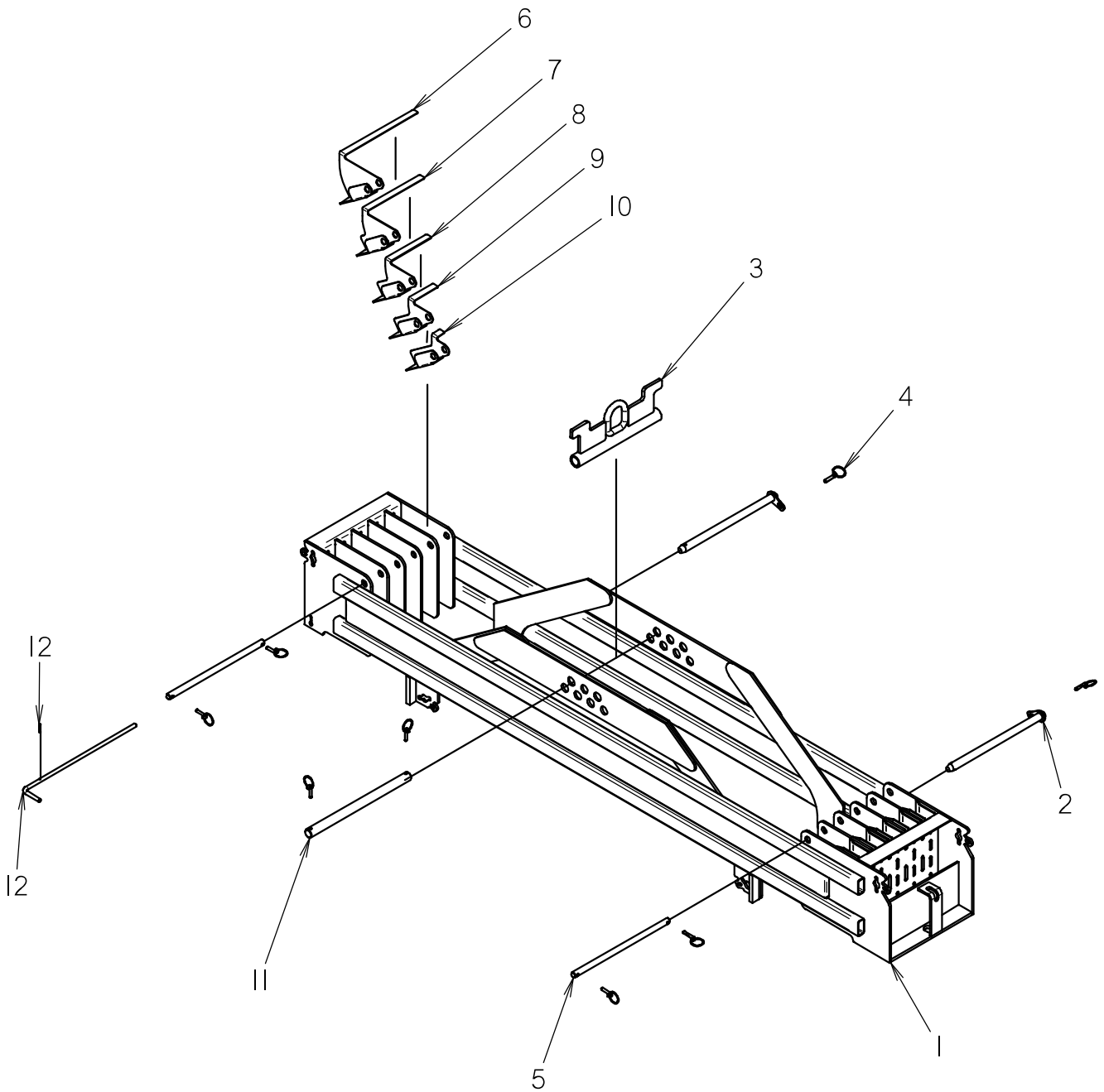

AT PIPE BOX (SHORT)

REF NO.	PART NUMBER	QTY	DESCRIPTION	REMARKS
	190-1137		AT SHORT PIPE BOX SUB	
1	300-1619	1	AT SHORT PIPE BOX	
2	300-1732	2	PIN	
3	313-252	1	LIFT BLOCK	
4	110-228	8	LYNCH PIN (7/16" X 2")	
5	300-1723	2	BAR	
6	300-2298	1	FLAG	
7	300-2297	1	FLAG	
8	300-2296	1	FLAG	
9	300-2295	1	FLAG	
10	300-1007	1	FLAG	
11	300-1724	1	LIFT BAR	
12	300-2294	1	FRONT PIN	

NOT SHOWN:

FOOTNOTES:

NOTE:

DRILLING FLUID TRANSFER

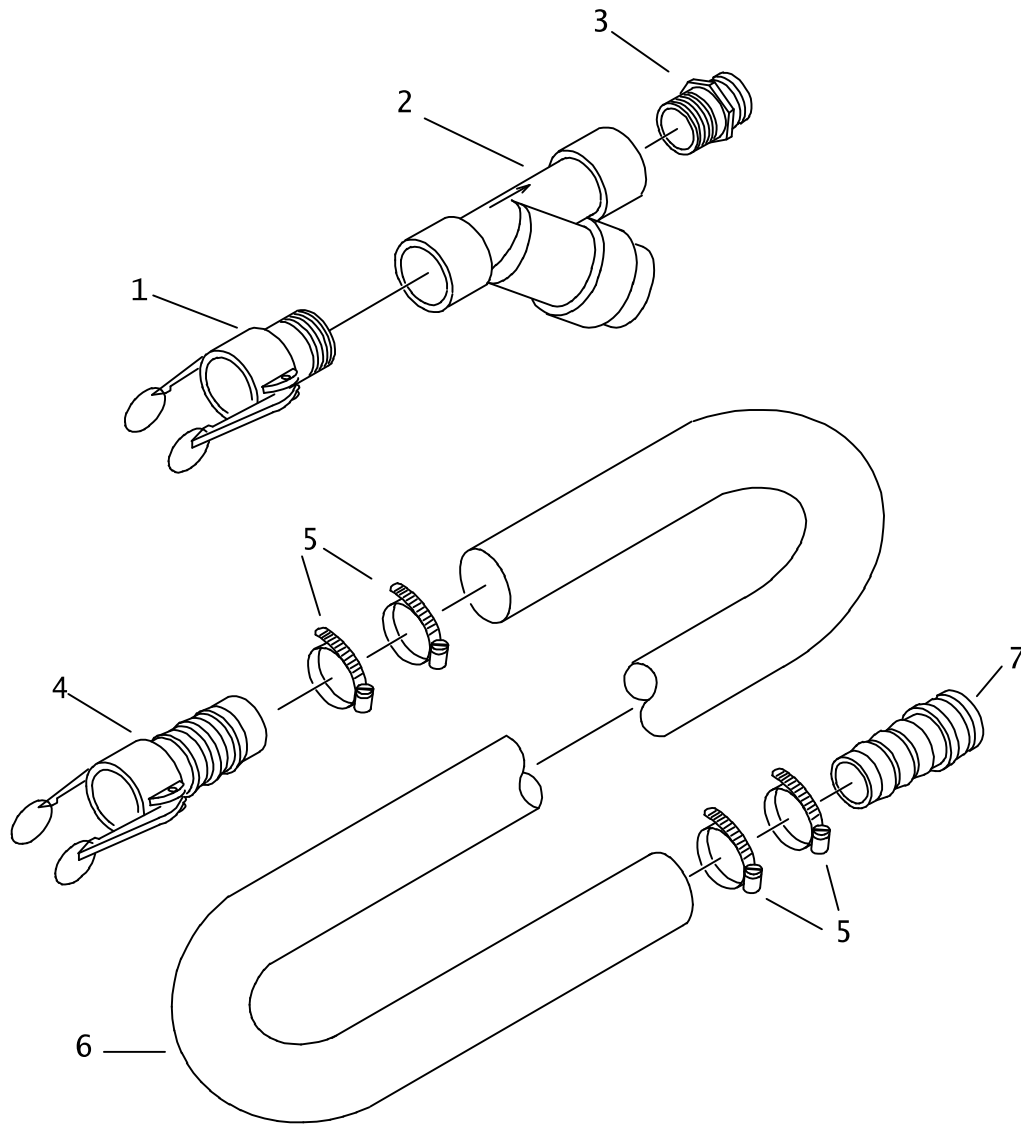

DRILLING FLUID TRANSFER

REF NO.	PART NUMBER	QTY	DESCRIPTION	REMARKS
	343-273	-	Y-STRAINER PARTS ASS'Y	INCL REF NO'S 1 - 3
	149-919		TRANSFER HOSE ASSY HD 2" X 50'	INCL REF NO'S 4 - 7
1.	159-485	1	FHC BODY (32-32N)	
2.	159-176	1	Y-STRAINER (32NF)	
	159-239		STRAINER (2.2" X 7")	
3.	159-181	2	FHC ADAPTER (40-32N)	
4.	159-180	1	FHC BODY (40-32H)	
5.	110-134	4	WORM CLAMP (2-1/6" TO 2-3/4")	
6.	116-973	1	TRANSFER HOSE (50 FT)	
7.	149-119	1	FHC ADAPTER (32-32H)	

NOT SHOWN:

FOOTNOTES:

NOTE:

01

ID0183211

GROUNDING HARDWARE

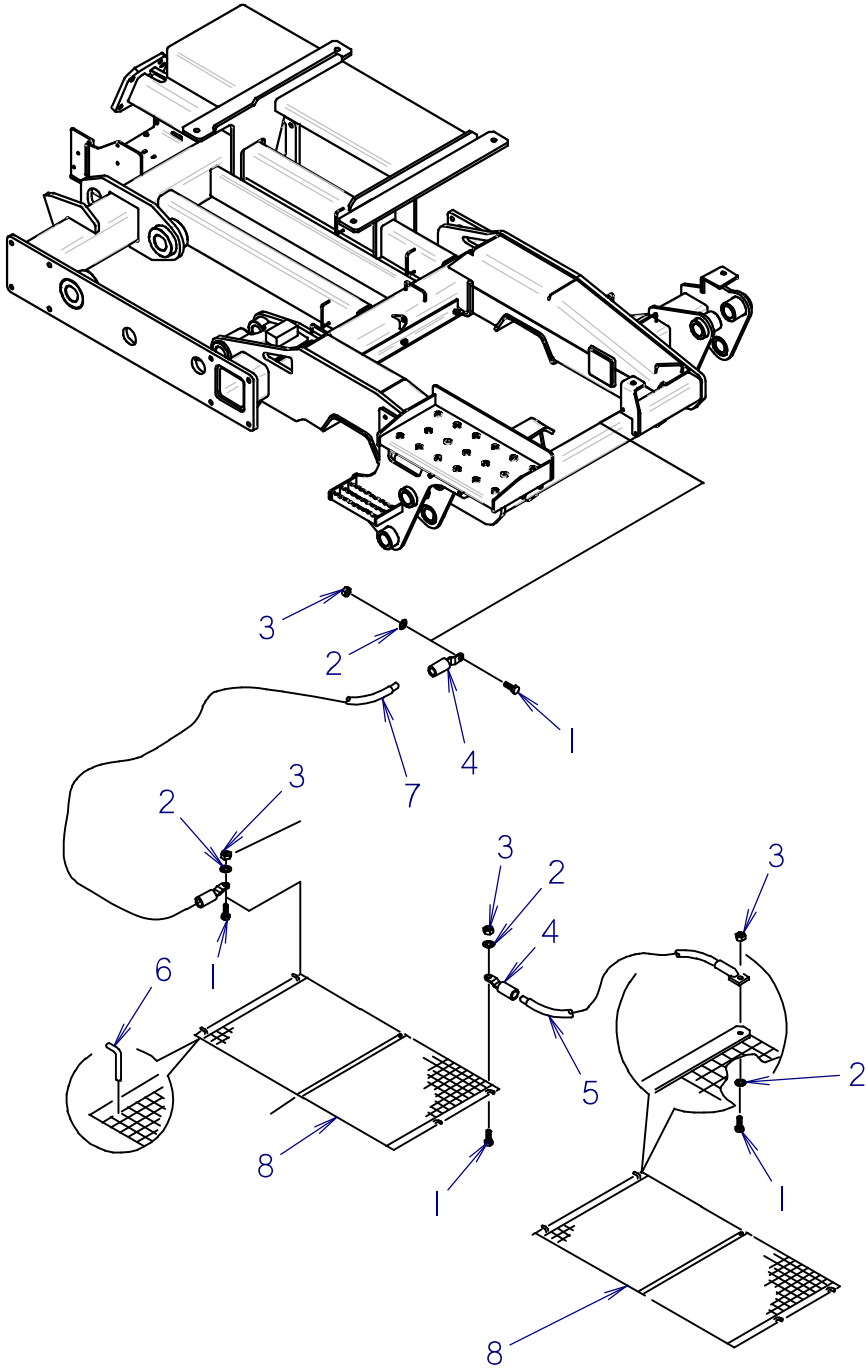

GROUNDING HARDWARE

REF NO.	PART NUMBER	QTY	DESCRIPTION	REMARKS
	100-074	-	STRIKE MAT KIT	INCL REF NO'S 1-8
1.	106-217	4	BOLT (1/4-NC X 1", SIL BRZ)	
2.	106-221	4	INT STAR WASHER (1/4", SIL BRZ)	
3.	106-455	4	LOCKNUT (1/4-NC, SIL BRZ)	
4.	215-771	2	GROUND RECEPTACLE (.3125" FM)	
5.	215-827	1	GROUND CABLE (6 GA X 6' M-EYE)	
6.	183-658	8	MAT STAKE	
7.	215-790	1	GROUND CABLE (6GA X 20' M-EYE)	
8.	215-824	2	GRID (6')	

NOT SHOWN:

FOOTNOTES:

NOTE:

MISCELLANEOUS

SAE Bolt and Nut Torque Value Chart

Grade 5: UNC or UNF Thread

Size	Hex nut, or bolt tapped into hex nut, or d&t hole		Hex top deformed locknut		Flange nut, locknut, or bolt tapped into flange nut or d&t* hole	
	ft•lb	N•m	ft•lb	N•m	ft•lb	N•m
1/4	12	16	8	11	20	27
5/16	25	34	15	20	45	60
3/8	40	54	25	34	75	100
7/16	65	90	40	55	125	170
1/2	100	135	60	80	190	260
9/16	150	200	90	125	270	370
5/8	200	270	120	165	370	500
3/4	350	475	210	285	650	880
7/8	560	760	340	460	1250	1425
1	840	1140	500	680	1580	2145
1-1/8	1030	1400	320	840	1950	3645
1-1/4	1460	1980	880	1195	2760	3475

Grade 8: UNC or UNF Thread

Size	Hex nut, or bolt tapped into hex nut, or d&t hole		Hex top deformed locknut		Flange nut, locknut, or bolt tapped into flange nut or d&t* hole	
	ft•lb	N•m	ft•lb	N•m	ft•lb	N•m
1/4	14	19	10	14	24	33
5/16	30	40	18	25	50	70
3/8	55	73	35	50	90	125
7/16	85	115	50	70	140	190
1/2	130	175	80	110	220	300
9/16	190	260	110	150	310	420
5/8	260	355	160	245	430	585
3/4	450	610	270	365	750	1015
7/8	730	990	440	600	1210	1640
1	1090	1480	650	880	1320	2465
1-1/8	1550	2100	930	1260	2580	3500
1-1/4	2180	2955	1310	1780	3640	4935

*drilled and tapped

Metric Bolt and Cap Screw Torque Values

Size	Class 4.8				Class 8.8 and 9.8				Class 10.9				Class 12.9			
	Lubricated		Dry		Lubricated		Dry		Lubricated		Dry		Lubricated		Dry	
	N•m	ft•lb	N•m	ft•lb	N•m	ft•lb	N•m	ft•lb	N•m	ft•lb	N•m	ft•lb	N•m	ft•lb	N•m	ft•lb
M6	4.8	3.5	6	4.5	9	6.5	11	8.5	13	9.5	17	12	15	11.5	19	14.5
M8	12	8.5	15	11	22	16	28	20	32	24	40	30	37	28	47	35
M10	23	17	29	21	43	32	55	40	63	47	80	60	75	55	95	70
M12	40	29	50	37	75	55	95	70	110	80	140	105	130	95	165	120
M14	63	47	80	60	120	88	150	110	175	130	225	165	205	150	260	190
M16	100	73	125	92	190	140	240	175	275	200	350	225	320	240	400	300
M18	135	100	175	125	260	195	330	250	375	275	475	350	440	325	560	410
M20	190	140	240	180	375	275	475	350	530	400	675	500	625	460	800	580
M22	260	190	330	250	510	375	650	475	725	540	925	675	850	625	1075	800
M24	330	250	425	310	650	475	825	600	925	675	1150	850	1075	800	1350	1000
M27	490	360	625	450	950	700	1200	875	1350	1000	1700	1250	1600	1150	2000	1500
M30	675	490	850	625	1600	950	1650	1200	1850	1350	2300	1700	2150	1600	2700	2000
M33	900	675	1150	850	1750	1300	2200	1650	2500	1850	3150	2350	2900	2150	3700	2750
M36	1150	850	1450	1075	2250	1650	2850	2100	3200	2350	4050	3000	3750	2750	4750	3500

Do not use these values if a different torque value or tightening procedure is given for specific application. Torque values listed are for general use only. Check tightness of fasteners periodically.

Shear bolts are designed to fail under predetermined loads. Always replace shear bolts with identical property class fasteners.

Fasteners should be replaced with the same or higher property class. If higher property class fasteners are used, these should only be tightened to strength of original.

Make sure fastener threads are clean and that the threads are properly started. This will prevent them from cross threading or galling when tightened.

Tighten plastic insert or crimped type steel locknuts to approximately 50% of dry torque indicated on chart. Apply torque to the nut - not the bolt head. Tighten toothed or serrated type locknuts to full torque value.

LUBRICATED means coated with lubricant. DRY means plain or zinc plated without any type of lubricant.

Hydraulic Cylinder Bolt Torque Chart

Bolt Size (inch)	Bolt Part No.	Cylinder Repair Kit Part No.	Torque (ft•lb)	Torque (N•m)
1/2	106-096	190-165	90-100	120-135
5/8	106-097	190-166 & 190-169	180-200	245-270
3/4	106-098	190-167 & 190-170	290-325	395-440
7/8	106-122	190-172 & 190-174	410-640	550-625
1	106-145	190-175 & 190-189	630-700	855-950
1-1/8	106-146	190-177	770-850	1045-1170

As a general rule:

- 1/2-inch bolts are used in cylinders with 1-inch rods
- 5/8-inch bolts are used in cylinders with 1 1/4-inch rods
- 3/4-inch bolts are used in cylinders with 1 1/2-inch rods
- 7/8-inch bolts are used in cylinders with 1 3/4-inch rods
- 1-inch bolts are used in cylinders with 2-inch rods (one with 1 3/4-inch)
- 1-1/8-inch bolts are used in cylinders with 2-1/4-inch rods

IMPORTANT: Do not reuse cylinder piston bolts when rebuilding a hydraulic cylinder. Each cylinder repair kit contains a new bolt. Use it. Lubricate lightly and torque to value shown on chart.

SAE & ORS Hydraulic Fitting Replacement O-Ring Chart

Fraction Size	Dash Size	SAE (Port Seal O-Ring)		ORS (Face Seal O-Ring)	
		Thread Size	O-Ring P/N	Thread Size	O-Ring P/N
1/16	1	NA	NA	NA	NA
1/8	2	5/16 - 24	NA	NA	NA
3/16	3	3/8 - 24	NA	NA	NA
1/4	4	7/16 - 20	155-760	9/16 - 18	157-037
5/16	5	1/2 - 20	NA	NA	NA
3/8	6	9/16 - 18	155-705	11/16 - 16	157-038
1/2	8	3/4 - 16	155-706	13/16 - 16	157-039
5/8	10	7/8 - 14	155-707	1 - 14	157-040
3/4	12	1-1/16 - 12	155-709	1-3/16 - 12	157-017
7/8	14	1-3/16 - 12	155-747	NA	NA
1	16	1-5/16 - 12	155-748	1-7/16 - 12	155-714
1-1/4	20	1-5/8 - 12	155-702	1-11/16 - 12	NA
1-1/2	24	1-7/8 - 12	157-001	2 - 12	NA
2	32	2-1/2 - 12	NA	NA	NA
2-1/2	40	3 - 12	NA	NA	NA
3	48	3-1/2 - 12	NA	NA	NA

Thread size indicates the diameter of the threaded area in fractions of an inch and number of threads per inch.

NA = not a current CMW part numbered o-ring, or dash size does not occur in current CMW applications

SAE = straight thread fitting that seals by sandwiching a hard o-ring between a shoulder on the male part and an angular surface at the mouth of the female port.

ORS = o-ring face seal; a type of fitting that seals by compressing a hard, captive o-ring between two flat parallel faces, one grooved for the o-ring and the other plain to act as the sealing surface

JT/AT3020

Related Publications

Component	Ass'y	P/N
Model:		
JT/AT3020 Parts Manual		053-1149
JT/AT3020..... Operators Manual		053-1152
JT/AT3020 Repair Guide (Service Manual)		N/A
JT/AT3020 Technical Supplement.....		053-1151
Engine:		
Cummins... .. Operators Manual – QSB 6.7.....	194-661	053-1035

Filters

Engine:		
Air Filter Parts Ass'y		194-871
Element (primary)		195-1040
Element (safety).....		195-1041
Oil Filter Element (spin-on).....		195-1034
Fuel Filter Primary Element.....		195-1035
Fuel Filter Secondary Element.....		195-1036
Hydraulic:		
Oil Filter Element (1-1/2-UNF, spin-on, Replacement) - Return		153-792
Element (1-1/2-UNF, spin-on, Break-In) - Return		153-791
Element (spin on) – Charge		149-939

Optional Kits

O-ring Repair Kit - FLG, ORS & SAE (15 different O-rings)	190-051
O-ring Repair Kit - Field Service (46 different O-rings)	190-052



Parts Manual Change Request

(Please print clearly)

Date: _____ Dealer No. (required): _____

Your Name: _____ Position: _____

Phone: _____ Fax: _____ E-mail: _____

Publication Information:

Parts Manual No.: _____ - _____ Model: _____

Illustration Part No.:	Manual Page No.:
1. _____ - _____	1. _____
2. _____ - _____	2. _____
3. _____ - _____	3. _____

Nature of Change Request:

- Text
- Graphics
- Missing Information

Describe change requested (if possible, include copy of publication page with changes marked.):

**Please fax completed form to
Parts Manual Department (580) 572-3525**

Thank you for taking the time to submit this request. We will contact you if further information is needed to process your request.

**A Note To
Ditch Witch
Equipment Owners:**

If your equipment was purchased through a Ditch Witch dealer, there is no need to read further.

However, if you purchased from any other source, please fill out the form on the reverse side and return it to us.

This will enable you to receive updates on this equipment as well as information on new products of interest.

Thanks for using Ditch Witch equipment.

(Please Fold Along This Line And Seal At Bottom With Tape)

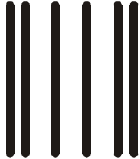

**NO POSTAGE
NECESSARY
IF MAILED
IN THE
UNITED STATES**

BUSINESS REPLY MAIL
FIRST CLASS PERMIT NO 23 PERRY OKLAHOMA

POSTAGE WILL BE PAID BY

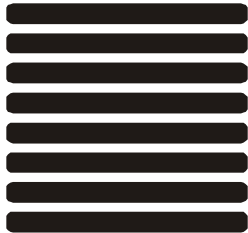

**The Charles Machine Works, Inc.
P.O. Box 66
Perry, Oklahoma 73077-9989**



Ditch Witch® Registration Card

Please Type or Print All Information

Purchaser's Company Name

Attention

Street Address or P.O. Box

City County

State Zip Nation

()

Phone Number With Area Code

Model S rial Number

Attachments/Accessories Serial Numbers

Attachments/Accessories Serial Numbers

Attachments/Accessories Serial Numbers

Name of Ditch Witch Dealership

Your Signature